

**Lincolnshire County Council**  
**Highway and Flood Authority**

**DEVELOPMENT ROAD and SUSTAINABLE DRAINAGE SPECIFICATION  
and  
CONSTRUCTION**

**March 2021 Edition**

*To be used in the Construction of  
Development Roads and Sustainable  
Drainage Systems which are to become  
Highways Maintainable at the Public Expense*

Lincolnshire County Council  
County Offices  
Newland  
LINCOLN  
LN1 1YL

## **FOREWORD**

### **INTRODUCTORY STATEMENT**

**This document supersedes all previous versions up to and including version 4.2 of “Development Road and Sustainable Drainage Specification and Construction May 2018 Revised Edition.”**

**It should be read and used in conjunction with the Lincolnshire Development Roads and Sustainable Drainage Design Approach.**

**This revised edition makes modest changes to the requirements for sustainable urban drainage systems (SuDS) and their application and refines a small number of clauses following feedback from users.**

**Electronic copies of this Specification, links to the Key Construction and Inspection Stage Certificates and Standard Details drawings can be found on the County Council website, LCC Connects:-**

**[www.lincolnshire.gov.uk/DRS](http://www.lincolnshire.gov.uk/DRS)**

**This Specification will be subject to review and amendment. The version of the Specification, including the Key Construction and Inspection Stage Certificates (Appendix 1) current at the time of signing the Section 38 agreement, will apply to works covered by that agreement.**

**Version 4.3 of this document is the thirteenth revision and is dated 1<sup>st</sup> March 2021.**

## CONTENTS

Clause		Page No
<b>GENERAL GUIDANCE NOTES</b>		
G.1	Introduction	8
G.2	Planning Permission	8
G.3	S38 Application	8
G.4	Risk Payments	11
G.5	S38 Requirements Inspection, Testing and Reporting	11
G.6	Works Within the Public Highway	12
G.7	Health and Safety File	13
G.8	Construction Design and Management Plan	15
G.9	General Guidance Notes	16
G.10	Roads and Surface Water Drainage and SuDS Layout	16
G.11	Vertical Alignment for Highways	16
G.12	Disposal of Road Surface Water	16
G.13	Permanent Traffic Signs and Road Markings Works	17
G.14	Service and Service Ducts	18
G.15	Permanent Cold-Lay Surfacing Materials	18
G.16	Specifications, Codes of Practices etc	18
G.17	Delivery Tickets for Approved Materials	18
G.18	Proximity of Non-Adoptable Structures	18
<b>1. CONSTRUCTION STANDARDS</b>		
1.1	General Principles	19
1.1.1	Conformity of Standards	19
1.1.2	Variation of Approved Details	19
1.1.3	Construction Charts	19
1.1.4	Roads Carrying Over 2.0 m.s.a.	19
1.1.5	Concrete Roads	19
1.1.6	Site Investigation	20
1.1.7	Flood Risk Assessment/Statement and Drainage Strategy	21
1.1.8	Sub-Grade	21
1.1.9	California Bearing Ratio Test (CBR)	22
1.1.10	Carriageway Construction Thickness (Frost Susceptibility)	22
1.1.11	Laboratory Results and Test Reports	23
1.1.12	Contaminated Land	23
1.1.13	Plate Bearing Tests	24
1.1.14	Approved Suppliers, Test Methods and Working Standards	24
1.1.15	Trafficking of Binder Course	24
1.1.16	Trafficking of Roads, Contamination and Storage of Materials	24
1.1.17	Kerbing	24
1.1.18	Minimum Depth Flexible Construction	26
1.1.19	Surface Water Drainage Swales and Flow Conveyance	26
1.1.20	Pervious Pavements for Surface water Drainage	26
1.1.21	Surface Water Drainage Filter Drains, Infiltration Trenches and Filter Strips	27
1.1.22	General Sectional Details of Non Pervious and Pervious Road Construction	28
	General Section Detail (Figures 1/1a and 1/1b)	29-30

Clause		Page No
1.2	Sub-base	31
1.3	Binder Course	31
1.4	Surface Course	31
1.5	Footway Construction	31
	Temporary Footways (Figure 1/2)	33
	Junction Detail with Existing Carriageway (Figure 1/3a and b)	34
	Domestic Vehicle Crossings (Figure 1/4)	35
	Heavy Duty Access Crossings (Figure 1/5)	36
1.6	Vehicle Access Crossings	37
1.7	Waiting Bay or Layby Construction	37
1.8	Tactile Paving at Crossings for Pedestrians	38
	Dropped Kerb Detail (Figure 1/6)	39
	Use of Tactile Paving (Figure 1/7)	40
	Tactile Paving Typical Detail (Figure 1/8)	41
1.9	Small Block Pavers	42
1.10	Construction Charts	42
	Construction Chart 1 (Up to 0.25 m.s.a.) – Normal Flexible Construction	43
	Construction Chart 2 (Up to 0.25 m.s.a.) – Min. Depth Flexible Construction	44
	Construction Chart 3 (Up to 0.25 m.s.a.) – Block Paver Construction	45
	Construction Chart 4 (Up to 2.0 m.s.a.) – Normal Flexible Construction	46
	Construction Chart 5 (Up to 2.0 m.s.a.) – Min. Depth Flexible Construction	47
	Construction Chart 6 (Up to 2.0 m.s.a.) – Non-pervious, Block Pavers	48
	Construction Chart 7 (Up to 0.25 m.s.a.) – Pervious Pavement, Block Pavers	49
	Notes to Construction Chart 7	50
<b>2.</b>	<b>TYPICAL SECTIONS THROUGH CARRIAGEWAY EDGE AND FOOTWAY EDGE</b>	
	Figure 2/1a and b Charts 1 to 6 Type Roads	51
	Figure 2/1 c Footway Construction Adjacent to Swale	51
	Figure 2/2 Transition Detail	52
	Figure 2/3 Channel Block and Kerb Detail	53
	Figure 2/4 Service Margin Detail – shared Surface	53
	Figure 2/5 Chart 1 Type Road Utilising Alternative Method of Kerb Installation. (Two Stage Construction; kerbing to be added at a later stage)	54
	Figure 2/6 Kerb Detail	55
<b>3.</b>	<b>TRAFFIC AND SAFETY MEASURES DURING CONSTRUCTION</b>	
3.1	Temporary Traffic Signs	56
3.2	Control of Traffic	56
3.3	Temporary Diversion of Traffic	57
3.4	Safety Codes	57
3.5	Excavations	57
3.6	Materials on the Highway	57

Clause		Page No
3.7	Mud, etc on the Highway	57
3.8	Wide Loads	57
<b>4.</b>	<b>SITE CLEARANCE</b>	
4.1	Clearing Site	58
<b>5.</b>	<b>DRAINAGE AND SuDS</b>	
5.1	Connections to Existing Drains or Public Sewers	59
5.2	Not Used	59
5.3	Pipes, Couplings, Fittings and Ancillary Products	59
5.4	Manholes	62
	Figure 5/1 Typical manhole detail Type A	66
	Figure 5/2 Typical manhole detail Type B	67
	Figure 5/3 Typical manhole detail Type C	68
	Figure 5/4 Typical manhole detail Type D	69
	Figure 5/5 Typical manhole detail Type E	70
	Figure 5/6a Access to Invert for Pipe Diameter Exceeding 600mm	71
	Figure 5/6b Typical Outfall Safety Grille	72
5.5	Gullies and Connections	73
	Figure 5/7 Typical Gully Details	74
5.6	Not Used	75
5.7	Geotextiles and Membranes	75
5.8	Brickwork and Blockwork	75
5.9	Covers and Frames	76
5.10	Excavation for Drainage Works including Channels, Swales and Ponds	78
5.11	Backfilling of Trenches, Filter Drains and Swales	78
5.12	Pipelaying	80
5.13	Bedding, Laying and Surrounding of Pipes	81
5.14	Inspection Testing and Cleansing	83
	Figure 5/8 Swales and Surface Water Flow Conveyance	86
	Figure 5/9 Typical Road Section Pervious Pavements	87
	Figure 5/10 Pervious Paving – Typical Plan for Carriageway binder Course Drilling	88
	Figure 5/11 Filter Drains and Infiltration Trenches	89
	Figure 5/12 Typical Inspection Chamber Detail	90
	Figure 5/13 Concrete Slab Pipe Protection	91
<b>6.</b>	<b>EARTHWORKS</b>	
6.1	Formation Level	92
6.2	Topsoil	92
6.3	Soiling, Grassing and Turfing	92
6.4	Embankments, Channels, Swales, Ponds and Cuttings	93
6.5	Dispersal of Standing Water	94
6.6	Excavations within Proposed Highway Limits	94
6.7	Ground Improvement	94
6.8	Granular Fill Below Formation	96
	Figure 6/1 Typical Road Section Subgrade CBR less than 1.5%	100
<b>7.</b>	<b>ROADWORKS – OVERALL REQUIREMENTS</b>	
7.1	Horizontal Alignment, Surface Levels, Layer Thicknesses and	101

Clause		Page No
	Surface Regularity	
7.2	Compaction of Bituminous Materials	102
7.3	Air Voids and Bond	104
7.4	Cold Weather Working	104
7.5	Use of Surface By Constructional Plant	105
7.6	Rectification	105
	Figure 7/1 Joints with Existing Construction	106
<b>8.</b>	<b>SUB-BASE</b>	
8.1	Aggregate for Sub-Base	107
8.2	Plate Bearing Tests	112
<b>9.</b>	<b>FLEXIBLE SURFACING</b>	
	General	113
9.1	Dense Binder Course	113
9.2	Bond and Tack Coat	113
9.3	Close Graded Surface Course for Carriageways	113
9.4	Dense Surface Course for Footways	113
9.5	Close Graded Surface Course for Temporary Footways	113
9.6	Rolled Asphalt Surface Course	113
9.7	Coated Chippings	114
9.8	Joints in Bituminous Construction	115
9.9	Recycled Material	115
9.10	Residual Binder Penetration	116
9.11	Not used	116
9.12	Annex B BS EN 13108-1 Asphaltic Concrete – Specification	116
9.13	Annex C BS EN 13108-4 Hot Rolled Asphalt - Specification	126
<b>10.</b>	<b>SMALL BLOCK PAVERS, KERBS, CHANNELS AND EDGINGS</b>	
10.1	Kerbs, Channels and Edgings (Standard)	132
10.2	Small Block Pavers: Concrete Block Paving	132
10.3	Small Block Pavers: Clay Pavers	133
10.4	Small Block Pavers: Laying Course	133
10.5	Table 10/1 Requirements for Aggregates used as laying course, fill for Binder	134
	Course Cored Drainage Holes & Jointing Material, Chart 6 Roads	
<b>11.</b>	<b>CULVERTS AND SMALL RETAINING WALLS</b>	
11.1	General	135
11.2	Ownership and Land Requirements	135
11.3	Design and Technical Requirements	137
11.4	Buried Services	138
11.5	Confined Spaces	138
11.6	Specification	139
11.7	Design Certification	139
11.8	Inspection During Construction	139
11.9	As-built Information Requirements for Structures	141
11.10	Construction of Retaining Walls Outside the Carriageway	142
	Figure 11/1 Non Adoptable Structures Adjacent to the Highway	143
	SD53 Concrete Outfall Unit with Flap Valve	144
	SD57 Brick Headwall	144

Clause		Page No
	SD/5/101 Reveted Kerb Headwalls up to 2m high	145
	SD/5/103 pipe Outfalls with ditches Suitable for pipes up to 225mm diameter	145
	SD/5/107 Reveted Bagwork Headwalls for up to 525mm pipe diameter	146
<b>12.</b>	<b>CONCRETE</b>	
12.1	Concrete Mixes	147
12.2	Cold Weather Working	148
12.3	Transport and Placing	148
12.4	Compaction of Concrete	148
12.5	Curing of Concrete	148
<b>13.</b>	<b>BRICKWORK</b>	
13.1	Brickwork: General	149
13.2	Exposed Joints	149
13.2.1	Pointed Joints	149
13.2.2	Unpointed Joints	149
13.3	Cold Weather Working	149
13.4	Facing Brickwork	149
<b>14.</b>	<b>STREET LIGHTING</b>	
14.1	Approval	150
14.2	Services	151
14.3	Standards	151
14.4	Installation	151
14.5	Completion and Commissioning Maintenance	151
<b>15.</b>	<b>PLANTING</b>	
15.1	Verges and Suitable SuDS Features	152
15.2	Tree Planting	153
	Figure 15/3 Tree Planting Detail (Method 1) The Single Stake Method	154
	Figure 15/4 Tree Planting Detail (Method 2) The Double Stake and Bar Method	155
	Figure 15/5 Tree Planting Detail (Method 3 & 4) Mesh Supported Trees	156
	Figure 15/6 Tree Planting Detail (Method 7 & 8) Spiral Guard Methods	157
15.3	Choice of Species	158
15.4	Tree Roots	158
15.5	Shrinkable Soils	158
15.6	Trees and Street Lighting	158
15.7	Retained Trees	158
<b>16.</b>	<b>INDUSTRIAL DEVELOPMENT ROAD LAYOUT PARAMETERS</b>	
16.1	Heavy Industrial Estate Road	158
<b>17.</b>	<b>PUBLICATIONS</b>	
17.1	British Standards	159
17.2	Other Publications	162

---

<b>Clause</b>		<b>Page No</b>
<b>18.</b>	<b>APPENDICES</b>	
	Appendix 1	166
	Key Stage Certificates	167
	Appendix 2 Section 38 Highway and Drainage Drawing Package	261
	General Requirements to Commence Detailed Design Check	
	Appendix 3 Structures Design Submission Requirements	267



## GENERAL GUIDANCE NOTES

---

### G.1 INTRODUCTION

- G.1.1 Lincolnshire County Council (LCC) has the statutory function of the Lead Local Flood authority (LLFA), and as well as being consulted on Highways, it is also a statutory consultee on local flood risk. Local Authorities, other bodies or persons developing land involving the construction of Development Roads and streets must apply in writing to the Highway and Flood Authority (HFA) prior to undertaking the work, and thereafter comply in full with the requirements of this document. Any variations that may be required by or agreed with the Highway and Flood Authority shall be in writing.
- G.1.2 Advice is provided on good highway design and construction, flood risk management and sustainable drainage (SuDS) principles at all stages of the planning process. Prospective developers are advised, therefore to consult the Highway and Flood Authority when considering new highway proposals, undertaking a Flood Risk Assessment or Flood Risk Statement, preparing a Drainage Strategy and planning application drawings for submission to the Planning Authority.
- G.1.3 Attention is drawn to the **Lincolnshire Development Roads and Sustainable Drainage Design Approach**, where information can be found on planning and adoption milestones and requirements. This lists the essential technical documents and information required at various stages of the planning and adoption processes to enable the necessary processes to be progressed.

### G.2 PLANNING PERMISSION

- G.2.1 Before making application to the Highway and Flood Authority, the Developer should first obtain planning permission from the Planning Authority concerned for the proposal as a whole. Application for this, or approval of reserved matters in the case where an outline planning permission has already been granted, must be made to the Planning Authority on the appropriate form obtainable from the Planning Authority Offices.
- G.2.2 The Planning Authority will need to be satisfied before granting planning permission for development involving the construction of roads and Sustainable Drainage Systems (SuDS), that those roads and SuDS will be at an acceptable level of flood risk and be laid out, constructed, drained, lit, marked and signed in such a manner that they can be taken over by the Highway and Flood Authority for maintenance at the public expense.
- G.2.3 A Developer must ensure that the proposal as a whole also meets requirements under any other legislation administered by the relevant Planning Authority.

### G.3 SECTION 38 APPLICATION

- G.3.1 S38 REQUIREMENTS Developers are reminded of the requirement to enter into a Section 38 Agreement with the Highway and Flood Authority. (The developers' attention is drawn to Appendix 2 of this document which includes the requirements for the scaled drawings for Section 38 agreements). If incomplete submission is made, the Section 38 Checking progress will be delayed until the information is received.
- G.3.1 To enter into a S38 agreement the development road should connect to the existing adopted public highway or a development road with a signed S38 agreement.

- G.3.2 In addition to obtaining planning permission from the Planning Authority, road constructional details and SuDS constructional details must be approved in writing by the Highway and Flood Authority and the associated Development Road Fee should be paid before any works commence on site.
- G.3.3 **UPFRONT FEES**  
An upfront fee of £2150 is required to proceed with the S38 submission, this sum includes £650 legal fees. £1500 will be deducted from the Development Road Fee on issue of the technical drawing approval. If the developer does not proceed with the S38 Agreement, this upfront fee is non-refundable.
- G.3.4 An upfront Bond and Development Road Fee estimate can be provided on submission of a S38. These figures are likely to be higher than actual values and are therefore indicative, they will not reflect detailed design or construction depths. Where the indicative bond figure cannot be met by the developer, discussions with the Development Management Team should be initiated to seek early resolution.
- G.3.4.1 Easements and land dedication may be subject to additional fees.
- G.3.5 **STATUTORY OBLIGATIONS**  
You are reminded that when dealing with the HFA, there are statutory requirements to comply with: The Data Protection Act; The Freedom of Information Act and the Environmental Information Regulations. It is also implicit that it complies with the Local Government Act 1972 and is required to act reasonably.
- G.3.6 **DESIGN, STRUCTURES AND DRAINAGE (DSD) MEETINGS**  
DSD meetings can be requested at any point from initial submission of a S38 to technical approval. The meetings can include Development Management Officers, Structures, Drainage, Lincs Laboratory, Landscaping, Street Lighting and Street Works & Permitting. They are an opportunity to discuss feedback comments and resolve any outstanding queries with the site.
- G.3.7 **DRAWINGS**  
In the first instance, attention is drawn to Appendix 2 and the requirements of the submission form.  
If an incomplete submission is made, the Section 38 Checking progress will be delayed until the information is received.
- G.3.8 The following note shall be incorporated on all drawings submitted: - "The specification in all respects shall be in accordance with the Development Road and Sustainable Drainage Specification and Construction".
- G.3.9 **COMMUTED MAINTENANCE PAYMENTS AND FEES**
- G.3.9.1 Alternative materials and features to those detailed in this specification are often more expensive to replace or have a shorter service life to those specified. In view of this the Highway and Flood Authority makes a charge to cover the additional maintenance costs for such materials and features.
- G.3.9.2 The additional costs associated with assessing such alternatives, including testing, will normally be borne by the proposer and the Highway and Flood Authority will require certain commuted sums to be paid by the developer for additional maintenance costs as follows:-

#### G.3.9.3 Sustainable Drainage Systems (SuDS)

When adopting SuDS components draining private water, and in addition to existing highway related bonds, fees and charges, a "one off" service payment will be required by the HIGHWAY AND FLOOD AUTHORITY from the developer (prior to commencement of SuDS construction), related to the current W&Sc surface water charge levied on property already connected to surface water sewerage infrastructure. Calculation details of this service payment will be provided by LCC at pre-planning application consultation stage.

For clarity, the Highway and Flood Authority will only consider for adoption any systems which are an integral part of the highway system. Roof water directly discharging into highway surface water drainage infrastructure from residential property may be acceptable following prior approval from the Highway and Flood Authority.

If drainage calculations require the installation of check dams a commuted sum will be required by the Highway and Flood Authority.

#### G.3.9.4 Non-Standard Surfacing and Alternative Materials

Where materials that are not within the current specification adopted by the Highway and Flood Authority are used in surfaced areas, a commuted sum for maintenance will be required.

#### G.3.9.5 Structures and Other 'Extra Over' Items

Highway structures; retaining walls, culverts, bridges and public transport infrastructure, are considered as 'extra over' standard adoptable works. These will require commuted sums to take account of their future maintenance.

Where items, as listed above, in this clause are proposed, the developer will be informed that a commuted maintenance payment will be written into the Section 38 Agreement.

#### G.3.9.6 Street Lighting, Street Furniture, Traffic Signals and Signs

Where the developer requires installations, finishing's, materials, features etc., which would incur additional maintenance or replacement costs (when compared with those required by the Highway and Flood Authority current specification), a commuted sum for the additional maintenance cost will be required.

#### G.3.9.7 Tree Planting and Root Barriers

Where trees are to be planted within 5m of footways or highways a root barrier is required between the tree root system and the highway structure. A proprietary, high strength, photo and bio degradation resistant root barrier 2mm thick with a minimum width of 1.0m should be used. Where individual trees are to be planted in tree pits with highway or footways adjacent, the use of preformed root directors may be more appropriate.

#### G.3.9.8 Services and Service Ducts

Utility services and service ducts shall be installed within the sub-grade below the carriageway or footway construction. Capping layers are classified as part of the

construction. The location of dedicated service crossing points requires approval in order to limit/control the number in road construction.

#### **G.4 RISK PAYMENTS**

- G.4.1 Please be aware that any works undertaken on the development without an inspection carried out by the Highway & Flood Authority representative will be at your own risk and you may be liable to either re-construction or payments for the future risk adopted by the HFA in accordance with Clause G.9 LCC's DRSC 2018 as detailed below
- G.4.2 In exceptional circumstances, the HFA will allow a 12 week period of grace, where work can be carried out on site and inspected by the HFA whilst land transfers are completed only on condition that full technical approval has been granted and the Development Road Fee has been paid in full and a pre start meeting has been undertaken. Should the developer fail to ensure the Section 38 Agreement is signed/sealed by all parties within the 12 week period of grace the HFA will cease inspections and the developer will be liable for either reconstruction or payments for the future risk adopted by the HFA due to lack of inspections of any subsequent key stages.

#### **G.5 S38 REQUIREMENTS, INSPECTION, TESTING AND REPORTING**

- G.5.1 Developers are reminded of the requirement to enter into a Section 38 Agreement with the Highway and Flood Authority. (The developers' attention is drawn to Appendix of this document which includes the requirements for the scaled drawings for Section 38 agreements). If incomplete submission is made, the Section 38 Checking progress will be delayed until the information is received.
- G.5.2 Any works carried out without inspection by a HFA representative will not be adopted unless the Developer can prove their acceptability by means of additional testing and interpretive reports and risk payments have been paid. In such cases the Highway and Flood Authority must ensure that construction has been carried out to an acceptable standard as required by this specification and that all materials are acceptable and approved.
- G.5.3 All requirements of this document must be demonstrated to have been met. There must be documentary evidence of a site investigation that demonstrates all the requirements of this document have been met.
- G.5.4 Where works have not been inspected and tested, the Highway and Flood Authority will require retrospective investigation and reporting, before an adoption will be considered. If such works are found to be defective, they will be required to be replaced at the Developer's expense. All additional testing costs shall be borne by the Developer.
- G.5.5 At the discretion of the HFA representative, the HFA may accept construction which has not been inspected or tested; in this instance the HFA will calculate a sum which the developer is required to pay for possible future risk to the Highway and Flood Authority due to the lack of inspection and testing for the relevant key stage(s). Retrospective Key Stage Certificates will be provided when the HFA representative is satisfied the relevant construction is acceptable. However, the bond will not be reduced at either Key Stage 5 or 9 without payment of the sum(s) for future risk and the HFA will not adopt until the payment(s) have been made.
- G.5.6 The developer's attention is drawn to the certification process which the County Council now operates for development roads and the requirement; in accordance with the

Section 38 Agreement, to have a nominated person who is responsible for managing construction and quality of the development. It is recommended that a pre commencement of works meeting is arranged with the Developer and the Principal Contractor to review approved drawings, road construction detail, the certification process and general site arrangement details. The nominated person will be responsible for notifying in good time (a minimum of 5 working days' notice) and providing facility for the authorised representative of the County Council to carry out the initial inspections and tests and obtain the subsequent certificates of construction and key stages of inspection for Traditional and SUDs construction, as detailed in Table G/1.

<b>Table G/1 Key stages and Certificates of Construction Traditional Construction (T)</b>	<b>SUDs Construction (S)</b>
Key Stage <b>T1</b> -Drainage	Certification for Pervious Pavements <b>S1</b> – stages Drainage to Kerbing.
Key Stage <b>T2</b> – Site Investigation/Formation/Earthworks	
Key Stage <b>T3</b> – Carriageway Subbase	
Key Stage <b>T4</b> – Kerbing	
Key Stage <b>T5</b> – Carriageway Binder Course	
Key Stage <b>T6</b> – Footways	
Key Stage <b>T7</b> – Block Paving	Certification for Pervious Pavements <b>S2</b> – Permeable Block Paving
Key Stage <b>T8</b> – Carriageway Surface Course	Certification for Swales & Filter Strips <b>S3</b>
Key Stage Inspection – Pre-Maintenance Period Inspection	
Key Stage Inspection – Pre-Adoption Inspection	

G.5.7 Should the developer fail to give sufficient notice (a minimum of 5 working days) and provide adequate facility for an authorised representative of the County Council to inspect test and certificate the above key stages of construction at the correct time, the County Council will require where appropriate, retrospective testing to be carried out at the Developer's expense and in addition the Developer will be required to pay sums to the County to meet any possible future risk to the Authority due to any lack of proper inspection and testing at the appropriate stages. Appendix 1 of this specification has example certificates and details of the inspection, testing and certification process.

## **G.6 WORKS WITHIN THE PUBLIC HIGHWAY**

G.6.1 Any necessary off site excavations, in association with the S38 application, that are to be carried out in the existing public highway will require the works promoter to provide the Highway and Flood Authority with accurate and timely information relating to works they are planning to carry out, as outlined under the New Roads and Street Works Act 1991 (NRSWA) and/or the Highways Act 1980.

G.6.2 Details of the works, including the nature, location and timing of the works must have prior agreement with the Highway and Flood Authority before starting any works. Any activity that has the potential to cause delay or disruption or any works that involves breaking up the existing highway are deemed notifiable works.

G.6.3 All supervisors and operatives working within the highway are required to hold a valid accreditation qualification as laid out in The Street Works (Qualification of Supervisors and Operatives) England, Regulations 2009. The developer or Contractor carrying out the works must hold a valid £10million or greater liability insurance certificate.

G.6.4 All works conducted within the public highway must be carried out and completed to the satisfaction of the Highway and Flood Authority and comply with the requirements of the Development Road Specification.

G.6.5 There are statutory minimum periods for you to comply with in relation to the following, which your development must take account of:

- Notification to statutory undertakers of the works, including time for them to respond;
- Temporary Traffic Regulation Orders (e.g. for road closures);
- Permanent Traffic Regulation Orders (e.g. changes to speed limits); and
- Permitting the works under the Lincolnshire Highway Permit Scheme which operates under Part 3 of the Traffic Management Act.

G.6.6 To arrange any traffic management or work within the existing highway, you must complete the Development Traffic Management Application here <https://www.lincolnshire.gov.uk/highways-planning/apply-temporary-traffic-management>. This should include details of proposed statutory utility connections and any other works which will be required in the public highway in association with this application. This will enable the HFA's Street Works and Permitting Team to assist you in the coordination and timings of such works. Please note that a minimum of three months' notice is required for any Temporary Traffic Regulation Order (i.e. road closure) application.

G.6.7 A separate permit or licence is required under the New Roads and Street Works Act 1991 for the laying of any drains/sewers or any other private connection (i.e. gas, electric) within the public highway. Applications should be made online at <https://www.lincolnshire.gov.uk/licences-permits/apply-highways-licence-permit>. Any Statutory Undertakers carrying out works in the public highway in connection with your development will serve their own notices under the Lincolnshire Permit Scheme.

G.6.8 Section 50 Licence Application

Where the drainage on the development is to remain private, and the responsibility of any party who does not possess a Street Works Act Code Licence, a S50 licence is required to maintain the private apparatus within the public highway. Application can be made using this link

<https://www.lincolnshire.gov.uk/licences-permits/apply-highways-licence-permit> The licence will need to be signed and returned to LCC with the S38 Agreement. LCC will retain the licence until such time as the roads and footway are adopted and become highway maintainable at public expense at which time the licence will be countersigned to secure the future maintenance of private apparatus in the highway. The licence will need to be signed and returned to LCC with the S38 Agreement. LCC will retain the licence until such time as the roads and footway are adopted and become highway maintainable at public expense at which time the licence will be countersigned to secure the future maintenance of private apparatus in the highway

## **G.7 HEALTH AND SAFETY FILE**

### **G.7.1 CDM REQUIREMENTS**

In accordance with Regulation 12/10 of the CDM Regulations 2015, prior to adoption of the site Developers must pass to the Highway and flood Authority their Health and Safety file, including any as built drawings for any structure, i.e. culverts, highway drains and the road itself. The Developer's CDM Principal Designer should ensure the Highway and Flood Authority is given this file which must include factors which could

influence future maintenance e.g. land contamination areas, maintenance of SuDS, drains and culverts, etc.

G.7.2 The Health and Safety File should include:

- **Location of the site**

- **Operation and Maintenance**

- Contact details for maintenance companies relevant to the site (landscaping, drainage features) including a plan of the area they will be maintaining.

- **SuDS Maintenance Plan**

Outline information on how SuDS will be managed and maintained, for the lifetime of the development. This should include:

- Maintenance plan- Clearly showing the extent of the adopted areas and those areas included in any maintenance agreements (contact details to be provided in section above.) This should include access arrangements (easements) and access points for each surface water management component for maintenance.
- Maintenance guidelines- Details of maintenance works to be undertaken based on regular, occasional tasks and remedial work so that performance is secured. Maintenance requirements for proprietary systems should be provided by the manufacturer or supplier.
- Maintenance Specification – Details of the materials to be used and general maintenance instructions.

- **Materials**

Details of non-standard materials or assets not included within the development road specification or anything which requires a commuted sum.

- **Structures**

Has the project changed an existing structure, or created a new structure? The client and future building users and maintainers need to know about any adjustments and limitations of the structure.

- The *Health and Safety File* must include as a minimum the following information:
- As-built drawings – Generally these are based on the approved construction drawings, and clearly marked up as such. Any alterations from the approved drawings must be included on these drawings. Nonspecific specification requirements must be replaced with specific product details, including suppliers.
- All pertinent manufacturer information relating to products used in the structure, including where appropriate the recommended inspection and maintenance requirements for the product.
- Test results and certificates for all mandatory testing undertaken.
- Information on any residual risks or hazards remaining following adoption of the structure, specifically including information regarding the future access arrangements for the inspection and maintenance of the structure.
- A fully completed *INVENTORY INPUT INFORMATION FORM* for each structure.
- Clear land plans at an appropriate scale showing the structure and; land dedication, ownership, adopted areas, and specifically any easements granted for the future maintenance or reconstruction of the structure.

- Services

Details on the locations of underground services including:

- Cables
- Gas
- Electrical
- Water

- As Built Drawings

Upon completion and before the development is entered into the maintenance period, the developer shall carry out an as built drainage and carriageway level survey and provide the Highway and Flood Authority with as built drawings showing the as built levels plotted against the design sections to demonstrate compatibility with the design and to ensure that minimum falls are achieved.

As-built drawings should be submitted as part of the requirements of the pre-maintenance period inspection key stage certification process. The as-built drawing outline should be representative of the previously agreed S38 layout title outline and any variation from this must have prior agreement from the HFA and may require a S38 Supplemental agreement, payable at the developers own cost.

The as-built drawing includes:-

- Scale 1:500 @ A1.
- E-file in pdf format, with an initial draft copy.
- Titled – "As-Built".
- Highway adoptable area shaded in solid light green, semi-transparent colour (no red boundary) and cover the entire area prepared for adoption.
- Road names
- Building outlines for the whole development.
- Road sewer layout with appropriate key and identify highway adoptable SuDS surface water system, including any off site dis-charge points.
- Identify any non-standard highway features.
- Show all Sec104 drainage.
- Identify any adoptable pervious pavement areas.
- Identify any Easement Areas.
- Identify lamp columns, adoptable tree, adoptable verges, tactile crossings, white lining, street furniture, highway retaining walls, culverted highway drainage, traffic calming features, visibility splays and any other highway feature.
- Identify any block paved areas.
- Identify the responsible party for each drainage asset

## **G.8 CONSTRUCTION DESIGN AND MANAGEMENT PLAN**

G.8.1 The purpose of producing a Construction Management Plan and SuDS Method Statement is to ensure that the developer and their contractors have adequately considered measures to manage impact to the existing highway network and taken reasonable steps to ensure risks from flooding and pollution are appropriately mitigated during the construction phase of the development.

G.8.2 The programming of SuDS construction is a vital consideration throughout all stages of the construction process. The main aim is to ensure the cleanliness of SuDS components during the construction phase.



G.8.3 The structure of the drainage will often be formed during the earthworks phase, but final construction should not take place until adequate provision has been made to protect SuDS features for the remainder of the construction phase. Consideration must be given to how surface water will be managed for this temporary period without causing flooding to surrounding land.

Further details can be found in CIRIA SuDS Manual and <https://www.lincolnshire.gov.uk/highways-planning/Guidance-for-developers/2>

## **G.9 GENERAL GUIDANCE NOTES**

### **G.9.1 SuDS AND ADOPTION OF SURFACE WATER DRAINAGE INFRASTRUCTURE**

Sustainable drainage principles should be incorporated in all developments as a requirement of both the planning process and the adoption process.

G.9.2 The Highway and Flood Authority will consider adopting surface water drainage infrastructure where it is proved to be an integral part of the highway system, and have been designed and constructed in accordance with this document and all Highway Authority requirements have been met, including payment of all appropriate fees.

G.9.3 Documents and information specifically required to be provided to the Highway and Flood Authority to enable a Section 38 agreement and subsequent adoption to be considered are shown in Appendix 2

G.9.4 For parts of the development where surface water drainage infrastructure is NOT an integral part of the highway system, the Developer is advised to enter into discussions with the most appropriate potential adopting authority at the earliest stage of the planning process.

## **G.10 ROADS AND SURFACE WATER DRAINAGE LAYOUT**

The general layout and design of the new roads shall comply with the Lincolnshire Development Roads and Sustainable Drainage Design Approach.

## **G.11 VERTICAL ALIGNMENT FOR HIGHWAYS**

G.11.1 The minimum longitudinal fall for highways, without channel blocks should be 1 in 150, and with channel blocks 1 in 250 within the catchment of traditional drainage design. (see Clause 10.1)

## **G.12 DISPOSAL OF ROAD SURFACE WATER**

G.12.1 Wherever possible, drainage systems should be designed to capture and re-use surface water to help reduce run-off volumes from the site and allow water, as a valuable resource to be put to good use e.g irrigating landscapes, watering gardens, car washing and toilet flushing etc. In some instances when suitable water treatment is undertaken, surface water can be used for human and animal consumption. However where re-use is not feasible (or is only part of the highway sustainable drainage solution); generally the aim should be discharge surface runoff as high up the following hierarchy of drainage options as reasonably practicable:

1. Into the ground (infiltration)
2. To a surface water body;
3. To a surface water sewer, highway drain or another drainage system; and
4. To a combined sewer.

- G.12.2 The normal process for the drainage of developments is that the Developer enters into an agreement with the appropriate surface water and SuDS infrastructure adopting authority. With regard to foul water sewers, the Developer enters into an agreement with the sewerage undertaker under Section 104 of the Water Industry Act 1991 for the design and construction of the foul water sewers, which are ultimately adopted by the sewerage undertaker as public sewers.
- G.12.3 This may include various SuDS components such as swales and flow conveyance, pervious pavements, filter drains, filter strips and including road gullies and the connections to the public sewer. Attention is drawn to the Lincolnshire Development Roads and Sustainable Drainage Design Approach, where information can be found on SuDS components and the indicative SuDS adopting authority. This lists various SuDS components within the SuDS train and the relevant authority which may consider adoption.
- G.12.4 Attention is also drawn to "Design and Construction Guide" containing the specification standards required by the water and sewerage companies.
- G.12.5 When a developer is considering using highway drainage infrastructure on a development the Highway and Flood Authority must be contacted at an early stage to determine the principles that the Highway and Flood Authority is likely to agree to prior to commencing any detailed design for a particular site.
- G.12.6 Prospective Developers must establish that road surface water can be disposed of satisfactorily and in accordance with the surface water disposal hierarchy above by means of an outfall approved by the Highway and Flood Authority, also establishing that they have the legal capacity to make such provision and to secure any necessary Third Party consents and easements for the Highway and Flood Authority.

### **G.13 PERMANENT TRAFFIC SIGNS AND ROADMARKINGS**

- G.13.1 Where it is deemed by the Highway and Flood Authority that, in the interests of highway safety and/or required by regulations, traffic signs are required to be erected and/or road markings need laying, as part of the development Developers will have to provide them at their cost.
- G.13.2 All traffic signs shall be designed and erected in accordance with the current "Traffic Signs Regulations and General Directions", the "Traffic Signs Manual" and any amendments and extensions thereof.
- G.13.3 For Directional, informative or warning signs with supplementary plates, a detailed drawing of the sign's face must be provided to Traffic Signs Section for approval – guidance may also be given on the required signing by this section if necessary.
- G.13.4 All traffic signs shall have a minimum guaranteed life of not less than 7 years; this guaranteed life must be not less than 10 years for Class 1 or Micro prismatic materials.
- G.13.5 Road markings shall be in accordance with BS EN 1436 and shall have the following minimum standards of performance for a minimum period of 2 years from the date of application.

**Table G/2 Performance Standards for Road Markings**

<b>Property</b>	<b>BS EN 1436 Reference</b>	<b>Requirement*</b>	<b>Value</b>
Colour	Table 6	White Yellow Class Y1, Y2	X, Y co-ordinates given X, Y co-ordinates given
Luminance Factor	Table 5	Class B2 Class B1	0.3 0.2
Skid Resistance	Table 7	Class S1 Class S1	45 45
Retroreflectivity	Table 2 Class of RL for dry markings	Class R2 Class R1	100 80
Retroreflectivity	Table 3 Class of RL for road markings in conditions of wetness	Class RWD	No Requirement

Note: 1 = White, 2 = Yellow

**G.14 SERVICE AND SERVICE DUCTS**

Utility services and service ducts shall not be installed within the carriageway or footway construction. They shall be placed within the underlying subgrade.

**G.15 PERMANENT COLD-LAY SURFACING MATERIALS (PCSMS)**

G.15.1 Permanent Cold-Lay Surfacing Materials (PCSMs) may be used to reinstate small areas at the discretion of the Development Management Officer.

G.15.2 Only PCSMs with a current HAPAS certificate shall be used.

G.15.3 PCSMs shall be stored, transported, handled and used strictly in accordance with the manufacturer's requirements contained in the HAPAS certification for the particular material.

G.15.4 **For the purpose of HAPAS Certification development roads constructed in accordance with this specification can be considered to be Type 3 and 4 roads.**

**G.16 SPECIFICATIONS, CODES OF PRACTICE ETC**

G.16.1 References made to Specifications, Codes of Practice, etc. are current at the time of publication. Where any are superseded by new documents the Developer should make reference to the most up-to-date edition at the time of construction.

**G.17 DELIVERY TICKETS FOR APPROVED MATERIALS**

G.17.1 Delivery tickets and, when applicable, evidence of C E Marking, shall be available on request by the Highway and Flood Authority officer.

**G.18 PROXIMITY OF NON-ADOPTABLE STRUCTURES**

G.18.1 Any non-adoptable structure that is within 3.66m of the highway boundary and/or 1.37m or higher, as measured from the finished level of the highway will require submission of structural calculations to demonstrate its suitability.

# 1. CONSTRUCTION STANDARDS

---

## 1.1 GENERAL PRINCIPLES

### 1.1.1 Conformity of Standards

The construction methods, materials and standards adopted shall conform with the following except where varied by this specification:-

The relevant British (and relevant European) Standard specifications.  
The Highways England's current Specification for Highway Works.  
TRL Laboratory Report 1132 - "The Structural Design of Bituminous Roads"  
The Highways England's current Pavement Design and Maintenance Manual (Volume 7) as amended by ADEPT guidance.  
Lincolnshire County Council Highways and Planning Directorate Code of Practice - "Highway Works: Standards, Materials, Testing - HT/14/1/94"

### 1.1.2 Variation of Approved Details

Details shall be to the satisfaction of the Highway and Flood Authority and any variation from the details approved must be communicated in writing and agreed in writing prior to the variation work being undertaken.

### 1.1.3 Construction Charts

Construction Charts 1, 2, 3 and 6 shall be used for Housing Development Roads carrying up to 0.25 million standard axles (m.s.a.). Construction Chart 1, 2, 3 and 6 roads typically serve up to 100 dwellings if a through route and a maximum of 50 dwellings if a cul-de-sac. Construction Chart 6 is not applicable to Spine Roads. Construction Charts 4, 5 and 6 shall be used for Housing Development Roads carrying between 0.25 m.s.a. and 2.0 m.s.a. and all Light Industrial Roads. The charts set out minimum standards of carriageway construction related to the bearing capacity of the sub-grade (CBR) and the weight and volume of the traffic using the particular road.

### 1.1.4 Roads Carrying Over 2.0 m.s.a.

The requirements of this specification apply to all Development Roads. Those intended to serve anticipated traffic categories in excess of 2.0 m.s.a. over a 40 year lifespan will require individual carriageway designs using the principles incorporated in TRL Laboratory Report 1132 or the Highways England's current Pavement Design Manual (Volume 7) as amended by ADEPT guidance. In these instances the Construction Charts in this specification are superseded. The materials to be used remain those detailed in this specification.

### 1.1.5 Concrete Roads

The construction charts do not include concrete roads and unless the Developer can produce overriding reasons for their use, they will not normally be permitted. If instances do arise where concrete construction is to be used, the design must be in accordance with the Highways England's current Pavement Design and Maintenance Manual (Volume 7). The design must be approved in writing prior to construction commencing and due to the amount of supervision and quality control tests necessary in the use of concrete, the Highway Authority will levy an additional supervision charge on an actual cost basis. The surface of any such concrete road shall be bituminous surface course, the details of which shall be approved by the Highway Authority in advance of construction commencing.

### 1.1.6 Site Investigation

It is important that the site investigations carried out are adequate in extent and quality. The site investigation must be in accordance with BS5930:2015 and where appropriate BS 10175:2011 + A1:2013. The following items must be included within the ground investigation report together with any other relevant information and an interpretative section.

- a) **The proposed works covered by the report;** i.e. highway design
- b) **Site Description;** to include descriptions of topography, boundaries, access, vegetation, water features, ditches, overland surface water flow routes, site hydrogeology, the presence of any structures or anything else which may be of importance to the future use of the site.
- c) **Geology;** a prediction of the site's geology which includes reference to British Geological Survey publications. In the section of the report which discusses the findings, a cross reference to the predicted site geology and found site geology must be made.
- d) **History;** where there is evidence that a site has been subject to pre-development or has become derelict, reference to present and past Ordnance Survey maps will be deemed necessary. Other undeveloped sites may not warrant such investigation, unless subsequent intrusive work reveals evidence of previous development. History of previous flooding of the site along with current consequences should be stated and quantified.
- e) **Site Work;** details of exploratory holes and/or trial pits excavated at the site. Exploratory holes should normally be spaced between 50m and 100m adjacent to the line of the proposed carriageway and encounter all the soil types on the site. Sufficient samples of each soil type must be taken from appropriate depths and tested at the relevant natural moisture content. For CBR testing, samples must be taken from the anticipated formation level to 0.5m below, except where there are different soil types when the weakest material must be sampled and tested. In-situ and laboratory testing should be undertaken as appropriate. Additional exploratory holes should be undertaken where ground conditions are variable; particularly where they are weak.
- f) **Made Ground/Fill;** the full depth and nature of made ground or fill shall be proven. Further intrusive work may be necessary to qualify and quantify the nature of this material along the line of the proposed adoptable road. Further work may be necessary in line with part h) below and Clause 1.1.11 (Contaminated Land). Made ground shall be removed beneath the line of the road.
- g) **If laboratory CBR tests are not undertaken as part of the site investigation, the CBR value shall be assumed to be below 1½% and the construction thickness provided as shown on Charts 1-7. This can only be assumed to be the case if the site investigation indicates the ground to be suitable. Obviously costs can be saved by conducting laboratory CBR tests.**
- h) **Infiltration tests shall be carried out in accordance with the [Bettess Report \(1996\)](#) [Infiltration drainage – manual of good practice CIRIA R156, which is based on the design approach in BRE 365 \(1991\)](#);**

Test pits are to be filled three times and the worst-case infiltration rate resulting is to be used when applying the appropriate factor of safety (as shown in [\\*Table 25.2 CIRIA SuDS Manual](#)), for calculating the required design capacity for infiltration storage and the pit should achieve 75% empty for each test.

The likely impact on the infiltration material, soil and underlying strata, and the long-term infiltration rates should be assessed;

Infiltration tests should be carried out at the location, depth and head of water that replicates the proposed infiltration design; and representative the variability of the ground conditions on the site and should be no more than 150m apart. A minimum of two trial pits should be carried out per site.

Infiltration rate tests and highway SuD designs shall be in accordance with the criteria stipulated by the Highway and Flood Authority and such designs shall adhere to the findings and recommendations of an appropriate and acceptable site investigation report (clause 1.1.6 (i))

Tests carried out in boreholes in accordance with BS EN ISO 22282-2:12 will not be accepted.

For effective infiltration, soils must be permeable and unsaturated. Where infiltration is the sole method of surface water disposal, there shall be a minimum of 1m depth between the underside of any SuDS structure and the highest recorded ground water level. Where possible, a minimum of twelve months seasonable, recently recorded evidence of relevant groundwater levels is required.

- i) **Laboratory Work**; must include an indication of where the testing was carried out and a comment on the accreditation status for each test.  
When assessing the ground for chemical content that is destructive to concrete the standard used to assess this is BRE Special Digest 1:2005. "Concrete in Aggressive Ground". This digest classifies sites that might contain chemicals that are harmful to concrete as "Brownfield" (C5.1.3) and those that are not as "Greenfield". Brownfield sites are sites or parts of sites that have had industrial development, storage of chemicals (including farms) or deposition of waste, (including leachate) containing aggressive chemicals. When the history of the site is not known it should also be classified as "Brownfield".
- j) **Contamination**; the site must be classified as 'Brownfield' or 'Greenfield'. All brownfield sites must be subject to contamination testing and an environmental risk assessment. Testing for contaminants on Greenfield sites need only be carried out if a specific reason to do so is identified. Further details are given in clause 1.1.11.
- k) **Infiltration Rate Testing** and Soakaway designs; compliance with the requirements of section 5 will be expected where the use of SuDS have previously been agreed with the Authority.

The site investigation will need to include description of the testing process used, soakaway test results, laboratory test results for soaked CBRs and particle size distributions for the subgrade, pH values of the subgrade and the means of determining the infiltration rate(s). Subsequently, design calculations and drawings will need to be submitted for approval.

#### 1.1.7 Flood Risk Assessment/Statement and Drainage Strategy

Information on flooding to and from the site, and drainage of the site, both now and in the future is required as indicated in the General Guidance Notes above.

#### 1.1.8 Sub-grade

- 1.1.8.1 The construction charts give alternative construction treatments for localised soft spots. If either the sub-grade or soft spots have a CBR below 1½% then specialist advice is required. It may be necessary to provide sub-grade drainage or other soil strengthening techniques such as incorporating a geosynthetic product or products (Clause 6.7.1) or stabilisation (Clause 6.7.2).

**1.1.8.2 The depth and type of treatment and the form of construction of the carriageway to be used must be agreed before the work commences.**

1.1.8.3 A Developer may consider the use of a combined or composite geosynthetic product which has two principal functions in a pavement foundation. The first is as a separator between the sub-base and sub-grade. The second is as a foundation reinforcing agent which can reduce the sub-base thickness with consequential economies in construction. See Figure 6/1.

1.1.8.4 The type of geosynthetic product to be used, its purpose and any proposed reduction in sub-base thickness must be agreed before construction commences (Clause 6.7.1).

**1.1.9 California Bearing Ratio Test (CBR)**

1.1.9.1 CBR samples must be recovered in conjunction with a site investigation carried out in accordance with Clause 1.1.6. The relevant CBR compaction method is described in BS 1377 (1990) Part 4 Clause 7.2.4.4 Method 5. Where more than 25% of material is retained on the 20mm sieve, advice shall be sought from a suitably qualified engineer. The engineer will advise the laboratory on what action to take with the material >20mm. The sample to be tested is to be a representative sample taken between the anticipated formation level and 0.50m below formation and should be compacted with a 2.5kg hammer and normally tested with six 2kg surcharge weights. A CBR result for the top and bottom of the compacted sample shall be reported.

1.1.9.2 Where a SuDS feature is proposed soaked CBRs in accordance with BS 1377 (1990) Part 4 clause 7.3 will be required at 50m to 100m intervals adjacent to the line of the proposed road. Any swelling of the samples should be recorded and reported.

1.1.9.3 The developer shall propose Design CBR(s) based on the Laboratory CBR results and the revealed ground conditions. These shall take into account allowances for cohesive sub-grades (details below).

1.1.9.4 The proposed design CBR will be agreed by the Highway Authority in order to derive the appropriate construction thicknesses given in Charts 1–7 (pages 36 to 44). In most instances, the worst CBR result will be used for the site as a whole, but a sub-grade inspection may be necessary to define where changes in design CBR values are to be used. (i.e. where ground conditions change).

1.1.9.5 As cohesive (or clayey) soils are moisture susceptible, the strength of clayey sub-grades may vary due to changes in water content before or after construction. In the absence of evidence to the contrary the maximum acceptable design CBR on cohesive sub-grades on estate roads is 3% (up to 0.25msa Charts 1 to 3 and 7) and 2% on major estate roads (up to 2msa Charts 4 to 6).

**1.1.10 Carriageway Construction Thickness (Frost Susceptibility)**

1.1.10.1 When CBR tests have been carried out, the thickness given in the tables may be used. Additionally, if tests show the sub-grade to be non-frost susceptible, then further economies in the thickness may be made. In such cases any proposed reduction in sub-base thickness must be agreed before construction commences.

1.1.10.2 For frost heave, materials shall be tested in accordance with BS 812: Part 124 as amended by Clause 801 of the Specification for Highway Works Volume 1 May 2007 except that the use of the silica sand and limestone filler reference specimens is not mandatory. Materials are classified as non-frost susceptible if the mean heave is 15.0mm or less.

### 1.1.11 Laboratory Reports and Test Results

1.1.11.1 The Highway Authority will accept reports containing test results only from UKAS Accredited Laboratories which are specifically accredited for the tests in question. The County Council's Materials Laboratory - Lincs Laboratory will offer further advice on this matter if requested to do so, and are able to carry out materials testing and consultancy work on a rechargeable basis. Lincs Laboratory is a UKAS Accredited Laboratory (Testing No 0699). Correspondence should be addressed to:- The Laboratory Manager, Lincs Laboratory, St Georges Lane, Riseholme, Lincoln, LN2 2LQ, telephone: (01522) 530355, fax: (01522) 510573 or E-mail [lincslab@lincolnshire.gov.uk](mailto:lincslab@lincolnshire.gov.uk).

### 1.1.12 Contaminated Land

1.1.12.1 This is any land that contains substances which, when present in sufficient quantities or concentrations, are likely to cause harm, directly or indirectly to man, to the environment or on occasions to other targets. In the event of the Developer or any individual working on the Developer's behalf encountering or having suspicion of encountering contaminated ground, the Highway Authority shall be informed at the earliest opportunity. Any contaminated land encountered **will need to be investigated** and reported in accordance with Clause 1.1.6. This is relevant for all previously developed sites and filled sites.

1.1.12.2 A "Stage 1 Environmental Desk Top Study" **shall be undertaken** if there is any suspicion of contamination. This will include an assessment of the following:

- (i) history of past use;
- (ii) visible signs of contamination or dumping;
- (iii) local and other information revealed about the site.

Risk of harm will be assessed using the source-pathway-receptor model.

1.1.12.3 If the Desk Top Study identifies significant risk of harm to the construction, environment, workforce, visitors, and end users then a "Quantitative Environmental Risk Assessment", which includes relevant testing for contamination, **shall be undertaken**.

The action to be taken from this quantitative assessment of risk will be:

- (i) Little or no risk – no action.
- (ii) Significant or real risk – some action to mitigate or reduce risk.
- (iii) Very significant or serious risk – action to remove the hazard or pathway.
- (iv) Highly significant or very serious risk – removal of hazard will take priority over construction considerations.

1.1.12.4 Where fill materials are to be placed in the vicinity of the development road then this work should be designed and constructed in accordance with the Specification For Highway Works under the guidance of, and signed off by a Chartered Geotechnical Engineer or Chartered Civil Engineer with specific experience in the design and supervision of earthworks.

Records should be maintained to enable the verification of the details of the works undertaken. Any remediation works undertaken on the site that require the placing of fill should also comply with this requirement.

Where the nature, extent and compaction of the fill cannot be determined from the available data, additional ground investigation works will be required at the additional cost to the developer.

Where SuDS are proposed on remediated ground or within fill materials these will be considered on a site by site basis depending on the nature of the fill, potential risk to the integrity of the development road and the proximity to aquifers or other watercourses.



### 1.1.13 Plate Bearing Tests

1.1.13.1 It is important that unbound granular materials are not segregated and are adequately compacted. Attention is specifically drawn to Clause 8.1. The Highway and Flood Authority will carry out Plate Bearing Tests or Light Drop Weight Tests to ensure compliance with this requirement.

### 1.1.14 Approved Suppliers, Test Methods and Working Standards

1.1.14.1 All materials shall be obtained from a source currently approved by the Highway and Flood Authority. The current list of suppliers is maintained by Lincs Laboratory and can be accessed via <http://microsites.lincolnshire.gov.uk/lincs/lab/publications/lcc-publications/>. Developers are advised to ensure that contractors working on their behalf are experienced in working to the standards required by the Highway and Flood Authority. Prior to conducting tests on behalf of the Developer, the Test House shall submit details of the Test Procedure to be used to the Lincs Laboratory. Testing shall not take place until the Test House has received approval for the proposed Test Procedure.

1.1.14.2 Developers are required to inform the Highway and Flood Authority of proposed material suppliers and sources and sub-contractors to be used, prior to the commencement of any such elements of work being conducted.

### 1.1.15 Trafficking of Binder Course

1.1.15.1 The Developer's attention is specifically drawn to the effect of trafficking exposed binder course materials prior to the application of the final surface course. The binder course shall be thoroughly cleaned and a tack coat to Clause 9.2 applied prior to the laying of the surface course. It may be necessary to use high pressure washing equipment if heavy contamination has occurred. Prolonged exposure to trafficking may result in the binder course becoming so adversely affected that its replacement will be necessary prior to laying the surface course. The use of sealing grit to BS EN 13108-1 and Annex B of this specification to protect the binder course if it is likely to be significantly trafficked is permissible. All traces of sealing grit shall be removed prior to the application of the surface course.

### 1.1.16 Trafficking of Roads, Contamination and Storage of Material

1.1.16.1 Traffic in connection with the related housing/building development must not use roads until constructed to the requirements of this specification. It is important that materials used in the construction of the areas to be adopted are not contaminated. Control should be such that only vehicles and plant associated with the roadworks be allowed to traffic the formation level and sub-base layers before and during construction. Formation that is damaged and sub-base that becomes contaminated by materials used in adjoining building works, top soil, clay, etc will not be adopted. At no stage during the construction of carriageways shall materials associated with the adjoining building works be stored thereon.

### 1.1.17 Kerbing

**1.1.17.1 Kerbs shall be installed prior to the full depth of the carriageway binder course being placed, unless the alternative working practice detailed below is employed following agreement, in advance, with the Highway and Flood Authority.**

1.1.17.2 The Developer's attention is drawn to the need to protect laid lengths of kerbing, channels and edgings. It may be necessary for this protection to take the form of a physical barrier such as concrete over protection with a polythene or geotextile membrane.

1.1.17.3 All damaged kerbs, channels and edgings shall be replaced prior to the application of carriageway or footway final surface course. **Where more than 4 separate kerbs, channels or edgings are damaged within any 10m length, the entire 10m length must be replaced**, using undamaged kerbs, channels or edgings in accordance with the specification.

1.1.17.4 Where it becomes necessary to replace kerbing, channels or edgings damaged following the application of final surface course to footway or carriageway, a minimum 2m length of Surface Course, full width of the footway, shall be replaced. If damage is caused to the adjacent carriageway surface course the surface course shall be replaced for a minimum of 5m for half the width of the carriageway. This Clause shall also apply where the Developer wishes to make minor changes to laid kerbing e.g. when adjusting the position of a vehicular crossing.

1.1.17.5 All kerbs needing replacement shall be removed from the footway side.

1.1.17.6 The kerb/channel bed, on development roads shall, always be laid separate to the backing as shown on the typical sections through carriageway edge details; drawings 2/1 to, 2/6. This is due to the high level of kerb damage experienced on development roads and the resulting need to replace kerbs at a late stage of construction whilst causing the minimum damage to the overall construction. In addition should the alternative kerb installation methods below be employed then the separate kerb bed/race can be utilised as level control for the first layer of binder course.

1.1.17.7 Minor kerb damage highlighted at the pre-adoption inspection stage, where all surfacing has been completed, may be repaired using a HAPAS approved dedicated epoxy kerb repair product, which preferably incorporates a priming system. A kerb repair is not allowed on any kerbs that have not received the final surfacing.

The following guidance should be used to determine if this method of repair is suitable or the traditional kerb replacement is required:-

- i. Maximum of 2 repairs per kerb.
- ii. Maximum of 2 kerb repairs per 20m length.
- iii. Allowable kerb repair depths are 5mm to 30mm.
- iv. Maximum kerb repair lengths 80mm.
- v. No conservation kerbs can be repaired.

1.1.17.8 For roads constructed in accordance with Construction Chart 1 **the alternative method of kerb installation** (two stage construction; kerbing to be laid at a later stage) is as follows:-

- The initial layer of binder course shall be 70mm thick.
- Kerbing to be installed prior to laying a further 60mm layer of binder course and the 40mm of surface course.
- Kerb bed/race laid prior to initial layer of binder course to assist with level control.
- Where the CBR of the sub-grade is less than 1½% specialist advice must be sought in accordance with Clause 1.1.8, with a bespoke pavement design being employed. Lincs Laboratory shall be consulted in these circumstances.

### 1.1.18 Minimum Depth Flexible Construction

- 1.1.18.1 Charts 2 and 5 provide alternative flexible designs based on the principle of replacing some of the granular foundation with bituminous material, known as 'bituminous replacement'. Highway construction practice on these thin foundations will have to be reviewed, normal procedures may not be appropriate due to the reduced ability of the foundation to carry construction traffic e.g. tracked rather than wheeled pavers to lay the binder course. Construction must be phased such that any excavated area is covered the same day with sub-base and this protected to prevent the ingress of water.
- 1.1.18.2 The sub-base shall conform with Clause 8.1 and shall be Type 1. Since part of the normal granular foundation has been replaced with bituminous material the in-situ CBR requirement on top of the sub-base is not appropriate. Instead the sub-base shall comply with the in-situ density requirement stated in Clause 8.1. This sub-base layer is not designed to carry other construction traffic.
- 1.1.18.3 When the sub-grade CBR is 3% or less consideration should be given at the site investigation stage to incorporate a geo-synthetic separator at the sub-grade/sub-base interface. Minimum depth flexible construction is not permitted on any site where the site investigation has identified a risk from soil shrinkage and heave.
- 1.1.18.4 The two design charts provide for frost protection when the sub-grade is classified as frost susceptible. Additional bituminous material has been included to provide the protection rather than increasing the thickness of non-frost susceptible Type 1 sub-base as in the normal flexible charts. Research has revealed that dense bituminous material offers added protection due to its increased insulating effect and by limiting water penetration into the pavement structure.

### 1.1.19 Surface Water Drainage Swales and Flow Conveyance

- 1.1.19.1 Application and the use of Swales and Flow Conveyance will be accepted to drain the following infrastructure:
- Primary distributor road
  - Local distributor road
  - Major access road
  - Minor access road
  - Shared surface road
- 1.1.19.2 Construction plant should not be driven over a swale or conveyance channel to avoid compaction of permeable soils. Where necessary, barrier fencing should be used, particularly where infiltration swales are being constructed. During construction surface water runoff should be prevented from entering swales from entering swales and channels. Where infiltration devices are being constructed they shall be backfilled and reinstated with a material of equivalent or greater infiltration potential including the surface layer. Materials on site should not be mixed.
- 1.1.19.3 Channels must be constructed to be self-cleansing of silt and allow easy cleaning and maintenance, and the outlet constructed to act as a mini separator for effective removal of pollutants. The preferred system to be used is a clear concrete channel of sufficient strength and durability, incorporating a defined edge.

### 1.1.20 Pervious Pavements for Surface Water Drainage

- 1.1.20.1 Application and the use of Pervious Paving in conjunction with infiltration (i.e. Type A and Type B) will be accepted to drain the following infrastructure:
- Minor access road
  - Shared surface road
- 1.1.20.2 Any pervious or block paved pavement must be installed in accordance with the manufacturer's installation instructions. The S38 submission must include a hydraulic and

structural design for the pervious pavement including test results for ground conditions and permeability of the underlying ground. Blocks are to be cut using an approved block cutting guillotine to no less than 1/4 (one quarter) of the original size.

1.1.20.3 Any materials used within the top 450mm of the constructed pavement shall be non-frost susceptible. Depths of sub-base will be determined from the ground investigations report and the hydraulic design. See Construction Chart 6.

#### 1.1.21 Surface Water Drainage Filter Drains, Infiltration Trenches and Grass Filter Strips

1.1.21.1 Application and the use of Filter Drains, Infiltration Trenches and Grass Filter Strips will be accepted to drain the following infrastructure:

- Primary distributor road
- Local distributor road
- Major access road
- Minor access road
- Shared surface road

1.1.21.2 Filter trenches must not be constructed near septic tanks or leachate areas. Where infiltration devices are being constructed they shall be backfilled and reinstated with a material of equivalent or greater infiltration potential including the surface layer. Materials on site should not be mixed. To prevent silting of the drainage pipe and soil erosion over time, a geo-textile membrane to clause 5.9 shall be used on the inside of the trench with a higher permeability than the surrounding soil. Filter drains shall not be brought into use until construction and landscaping of the surrounding site draining to them has been completed.

1.1.21.3 The use of infiltration trenches for disposal of surface water must be site specific. Protection to the infiltration trench shall be provided from all construction plant activity until construction on the site is completed, and it should not be used for drainage of the site during construction. Compaction of the surrounding ground shall be avoided so as not to affect the infiltration characteristics of the soil. The acceptable depth of infiltration trenches will be governed by several site-specific factors, including soil type and the ability to safely construct, inspect and maintain SuDS components (e.g. safely lay, wrap and maintain geotextile etc). Capping layers are classified as part of the construction.

1.1.21.4 Grass filter strips are to be constructed 25mm below the road channel level to prevent build-up of silt at the road edge and impeding run-off. The filter strip must be constructed to provide an even and consistent longitudinal slope, with no severe undulations that will cause localised ponding and promote flow in surface channels and erosion of topsoil. The design shall not allow water to over-run onto non-adopted areas. A newly constructed filter strip must be protected from stormwater flows unless a good sward of grass has been established. However, following planting, if more than 30% of the area is bare after 4 weeks, reseeding will be required to achieve a good 90% established sward. If sediment from construction works accumulates on the filter strip, removal will be required prior to adoption.

**Table 1/1 Summary of acceptable Sustainable Drainage Applications**

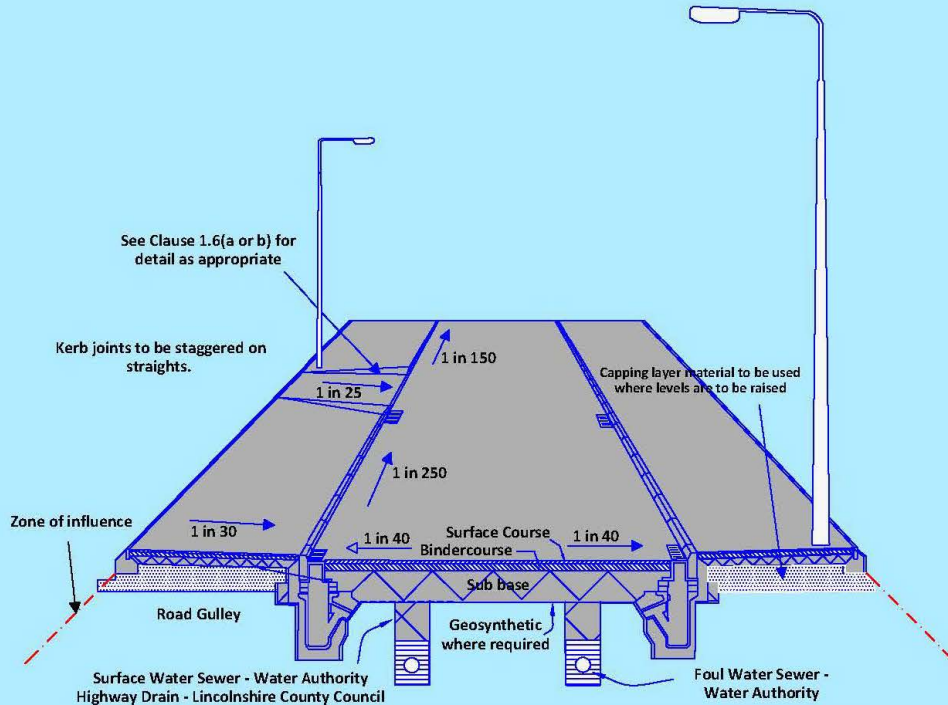
Infrastructure	Surface Water, Drainage Swales And Flow Conveyance (Clause 1.1.19)	Pervious Pavements for Surface Water Drainage (Clause 1.1.20)	Surface Water Drainage, Filter Drains, Infiltration Trenches And Grass Filter Strips (Clause 1.1.21)
Primary Distributor Road	√	x	√
Local Distributor Road	√	x	√
Major access Road	√	x	√
Minor Access Road	√	√	√
Shared Surface Road	√	√	√

Key

- √ Acceptable surface water drainage method
- X Unacceptable surface water drainage method

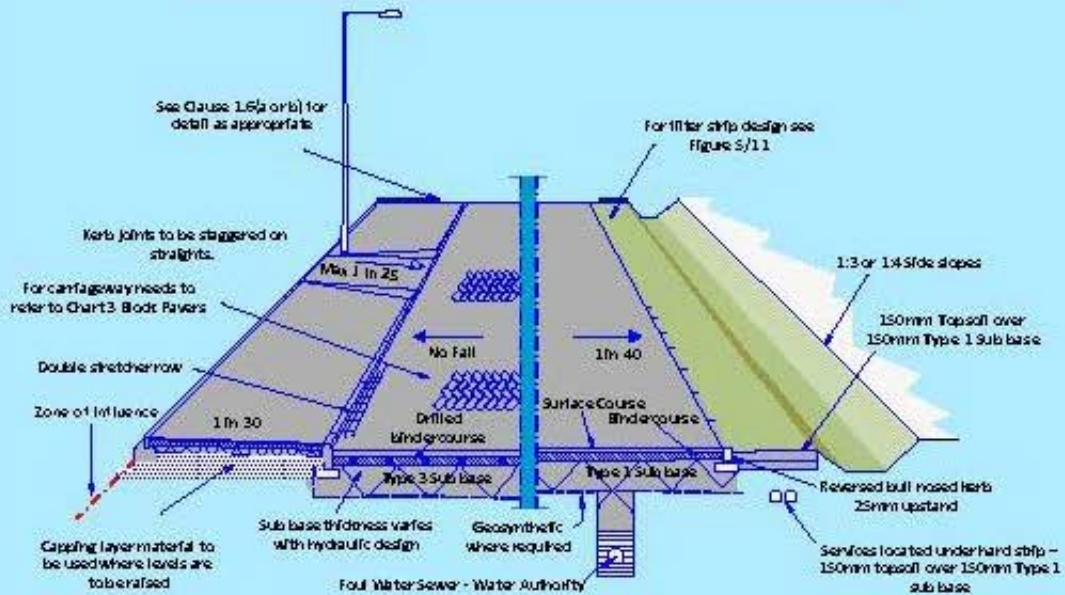
1.1.22 General Sectional Details of Non Pervious and Pervious Road Construction

**FIGURE 1/1(a) - GENERAL SECTIONAL DETAIL - TRADITIONAL  
(NB REFER TO SPECIFIC DETAILED SPECIFICATIONS)**



Element	Requirement	
1	Carriageway and footway Type 1 Sub base	To Clause 8.1 compacted to achieve a min in-situ CBR value of 30% and/or a min stiffness of 35 MPa when tested in accordance with Clause 8.2. For carriageways, sub base thickness varies with subgrade CBR value. For footways sub base is 150mm thickness in vehicle accesses and 100mm thick elsewhere.
2	Carriageway Bindercourse (AC20 Dense Bin 40/60)	To Clause 9.1 laid in two layers not less than 50mm in thickness nor greater than 80mm thickness. Compacted to Clause 7.2 to a void content within the range 2% - 8% with all layers bonded
3	Chart 1 and 2 Carriageway Surface Course (AC10 Close Surf 70/100 or 100/150)	To Clause 7.3 laid in a single compacted layer 40mm in thickness. Compacted to Clause 7.2 to a void content within the range 2% - 10% and bonded to the bindercourse.
4	Chart 4 and 5 Carriageway Surface Course (HRA 30/14 F Surf 40/60 des incorporating 20mm precast chippings of appropriate PSV)	To Clause 9.6 & 9.7 laid in a single compacted layer 40mm in thickness with a void content range of 2% - 6% and bonded to the bindercourse.
5	Footway Bindercourse (AC20 Dense Bin 70/100 or 100/150)	To Clause 9.1 laid in a single layer 100mm thickness. Compacted to Clause 7.2 to a void content within the range 2% - 10%.
6	Footway Surface Course (AC4 Dense Surf 70/100 or 100/150)	To Clause 9.4 laid in a single layer 25mm thickness. Compacted to a void content within the range 2% - 10% bonded to the bindercourse.
7	Block Paved Footways	<u>Type 1 sub base</u> - 100mm thickness as element 1 above
		<u>Bindercourse</u> - 60mm thickness of AC20 Dense Bin 70/100 or 100/150 res to Clause 9.1 compacted to a void content of 2% to 10%
		<u>Laying Course</u> - 30mm of bedding sand to Clause 10.4
		<u>Pavers</u> - 60mm Small Unit Pavers to Clause 10.2 or 10.3. Jointing sand shall be to Clause 10.4.
<b>NB</b> - Block paved footways are only permitted where the adjacent carriageway is constructed with block pavers to Chart 3 or Chart 6.		

**FIGURE 1/1(b) - GENERAL SECTIONAL DETAIL - PVIOUS PAVEMENTS, SWALES AND FILTER STRIPS (NB REFER TO SPECIFIC DETAILED SPECIFICATIONS)**



Element	Requirement
1 Carriageway and footway Type 1 sub base	To Clause 8.1 compacted to achieve a min in-situ CBR value of 30% and/or a min stiffness of 36 MPa when tested in accordance with Clause 8.2. For carriageway, sub base thickness varies with subgrade CBR value. For footways sub base is 150mm thickness in vehicle accesses and 100mm thick elsewhere.
2 Carriageway Type 3 sub base	To Clause 8.1 compacted to achieve a min in-situ CBR value of 30% and/or a min stiffness of 36 MPa when tested in accordance with Clause 8.2. Thickness varies with hydraulic design but with a minimum of 300mm.
3 Carriageway Bindercourse (AC20 Dense Bin 40/60)	To Clause 8.1 laid in two layers not less than 60mm in thickness nor greater than 80mm thickness. Compacted to Clause 7.2 to a void content within the range 2%- 8% with all layers bonded.
4 Chart 1 and 2 Carriageway Surface Course (AC10 Close Surf 70/100 or 100/150)	To Clause 7.3 laid in a single compacted layer 40mm in thickness. Compacted to Clause 7.2 to a void content within the range 2%- 10% and bonded to the binder course.
5 Chart 4 and 5 Carriageway Surface Course (HRA 30/14F Surf 40/60 des)	To Clause 8.6 & 8.7 laid in a single compacted layer 40mm in thickness with a void content range 2%- 8% and bonded to the binder course.
6 Footway Bindercourse (AC20 Dense Bin 70/100 or 100/150)	To Clause 8.1 laid in a single layer 100mm in thickness. Compacted to Clause 7.2 to a void content within the range 2%- 10%
7 Footway Surface Course (AC6 Dense Surf 70/100 or 100/150)	To Clause 8.4 laid in a single layer 25mm in thickness. Compacted to a void content within the range 2%- 10% bonded to the binder course.
8 Block Paved Footways	Type 1 sub base - 100mm thickness as element 1 above
	Bindercourse - 60mm thickness of AC20 Dense Bin 70/100 or 100/150 res to Clause 8.1 compacted to a void content of 2% to 10%
	Laying Course - 30mm of bedding sand to Clause 10.4
	Pavers - 60mm Small Unit Pavers to Clause 10.2 or 10.3. Jointing sand shall be to Clause 10.4
	<b>NB</b> - Block paved footways are only permitted where the adjacent carriageway is constructed with block pavers to Chart 3 or Chart 8

## **1.2 SUB-BASE**

- 1.2.1 Sub-base shall conform with Clause 8.1 and shall be Type 1 for Carriageways constructed to Charts 1 to 6 and footways. Type 3 sub-base is used in carriageways constructed to Chart 6, it is anticipated Type 3 subbase will provide voids in the range of 15% to 20%. A minimum in-situ CBR value of 30% and/or a minimum stiffness of 35 MPa will be required on all roads. CBR or stiffness values shall be determined by Plate Bearing Tests or Light Weight Drop Tests respectively in accordance with Clause 8.2.
- 1.2.2 For carriageways and footways, not more than one in ten field dry density determination, as detailed in BS 1377:Part 9, (clause 2.2) shall be less than 90% of the maximum dry density for that particular sub-base as determined by the vibrating hammer test in BS EN 13286-4.

## **1.3 BINDER COURSE**

- 1.3.1 For carriageways, Binder course materials shall be 20mm size recipe mix Dense Binder course **AC 20 Dense bin 40/60 rec** to Clause 9.1 and shall be laid in two layers of 70mm and 60mm respectively. No layer shall be less than 50mm in thickness or greater than 100mm in thickness. Compaction must be in accordance with Clause 7.2 to a void content within the range 2%-8% and all layers must be bonded together.

## **1.4 SURFACE COURSE**

- 1.4.1 For Charts 1 and 2 the Surface Course shall be 40mm of 10mm size Close Graded Surface Course (AC 10 close surf 70/100 or 100/150) to Clause 7.3. It must be compacted in accordance with Clause 7.2 to a void content within the range 2%-10%. The aggregate shall be from a source approved by the Highway and Flood Authority and shall have minimum polished stone value of 55, unless a higher PSV is required by the Highway and Flood Authority and a maximum abrasion value of 16. Only aggregates in the Lincolnshire County Council Approved Supplies Information Booklet shall be used.
- 1.4.2 For Charts 4 and 5 the Surface Course must be 40mm of Hot Rolled Asphalt (HRA 30/14F surf 40/60 des Incorporating 20mm pre-coated chippings minimum psv 60) to Clause 9.6 to a void content within the range 2%-6%.
- 1.4.3 The Surface Course shall be bonded to the Binder Course.

## **1.5 FOOTWAY CONSTRUCTION**

This shall comprise:-

### **1.5.1 Bituminous Surfacing**

100mm of Type 1 sub-base to Clause 1.2

100mm of 20mm size Dense, 70/100 or 100/150 Binder Course (AC 20 dense bin rec) to Clause 9.1 compacted to a void content within the range 2%-10%.

25mm of 6mm size Dense 70/100 or 100/150 Surface Course (AC 6 dense surf) to Clause 9.4 compacted to a void content within the range 2%-10%.

The Surface Course must be bonded to the Binder Course.

### **1.5.2 Block Paved Footways**

100mm of Type 1 subbase to Clause 1.2.



60mm of 20mm Dense Binder Course (AC 20 dense bin, 70/100 or 100/150 rec) to clause 9.1 compacted to a void content within the range 2% -10%.

30mm laying course of bedding sand to Clause 10.4.

60mm small unit block pavers to Clause 10.2 or 10.3. Jointing sand shall be to Clause 10.4.

#### 1.5.3 Footway construction adjacent swales or basins (see Figure 2/1c)

Geogrid over geotextile or composite of both to Clause 6.7 extending 500mm either side of footway

200mm of Type 1 sub-base to Clause 1.2 with a minimum 100mm extending 500mm either side of footway.

100mm of 20mm size Dense, 70/100 or 100/150 Binder Course (AC 20 dense bin rec) to Clause 9.1 compacted to a void content within the range 2%-10%.

25mm of 6mm size Dense 70/100 or 100/150 Surface Course (AC 6 dense surf) to Clause 9.4 compacted to a void content within the range 2%-10%.

The Surface Course must be bonded to the Binder Course.

#### 1.5.4 Temporary Footways

When agreed in advance with the Highway and Flood Authority sacrificial temporary footways may be installed where there is the need to provide a serviceable footway in advance of completion of all works that may adversely affect the footway.

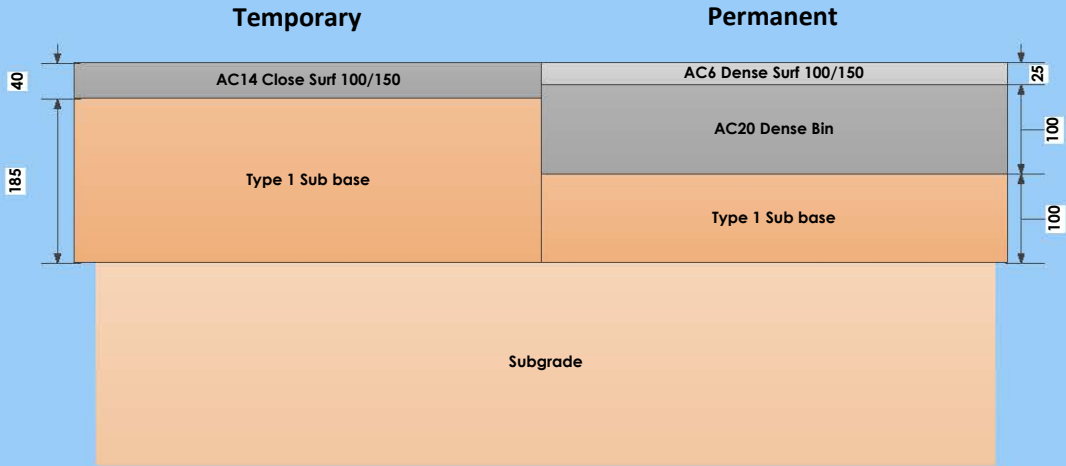
Temporary footways shall comprise-

185mm of Type 1 Subbase to Clause 8.1

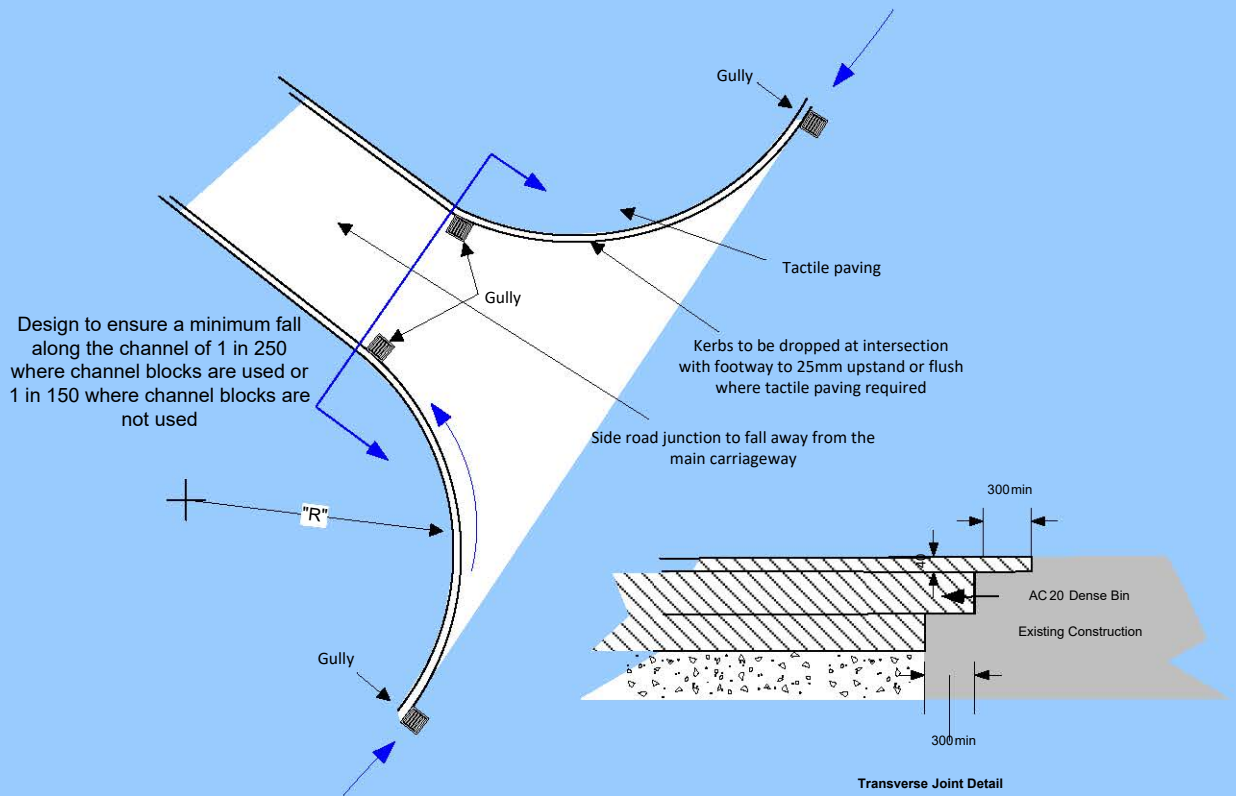
40mm of 14mm close graded 100/150 surface course (AC14 close surf 100/150) to Clause 9.5.

Temporary footways shall be replaced by footways complying with 1.5.1 or 1.5.2 above prior to adoption by the Highway and Flood Authority.

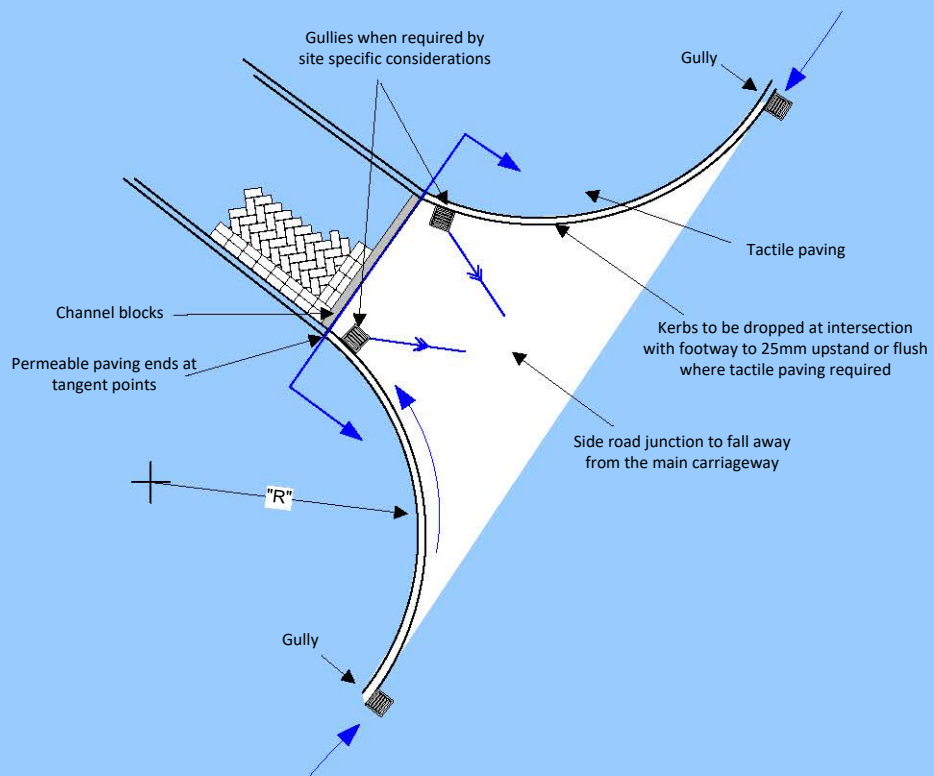
# FIGURE 1/2 - TEMPORARY FOOTWAY INSTALLATION



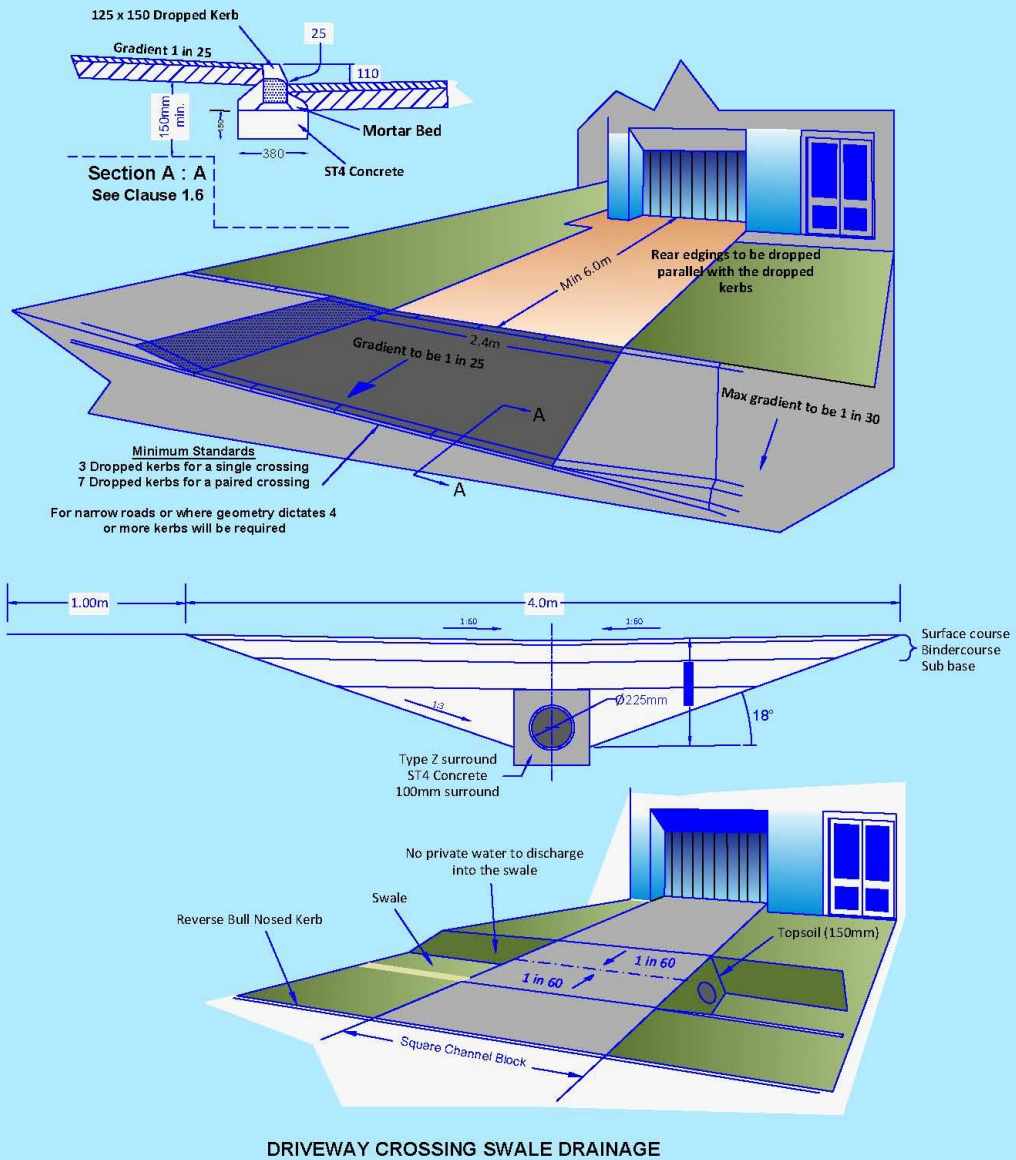
**FIGURE 1/3a - JUNCTION DETAIL WITH EXISTING CARRIAGEWAY**



**FIGURE 1/3b - JUNCTION DETAIL WITH PERVIOUS PAVEMENT**

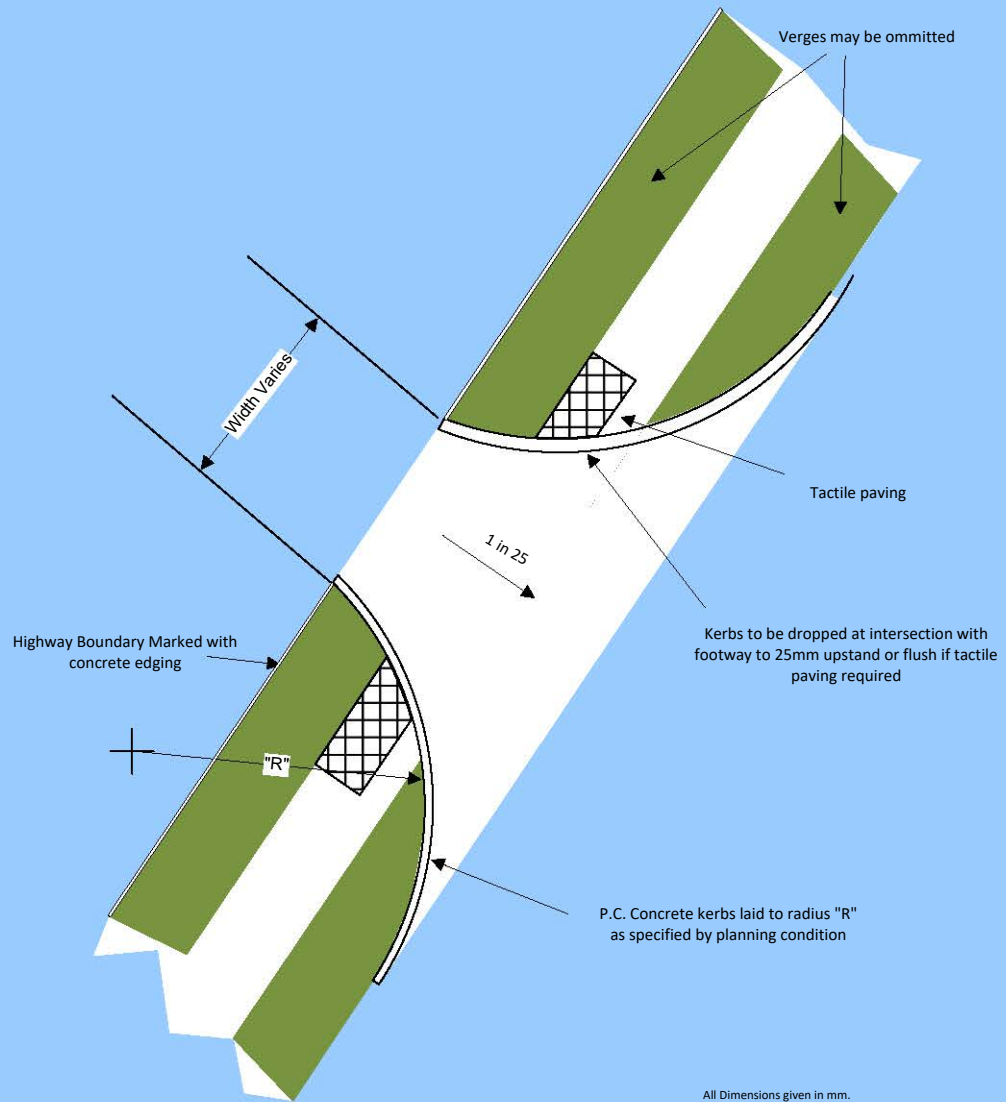


**FIGURE 1/4 - DOMESTIC VEHICLE CROSSING  
(REF. CLAUSE 1.6.1)**



*Where the developer proposes to discharge to a riparian water course they shall demonstrate it is fit for purpose. They shall provide a report detailing the condition of the bed, banks and structures to ensure there is no impediment to flow until it discharges into a publicly maintained network. The extent of the survey shall be until a point that the watercourse cannot cause an impediment to flow or it connects to a waterbody maintained by a public body. In the first instance a minimum distance of 100m heading downstream is required.*

**FIGURE 1/5 - HEAVY DUTY VEHICLE ACCESS CROSSING  
(Ref Clause 1.6.2)**



## **1.6 VEHICLE ACCESS CROSSINGS**

### **1.6.1 Light Duty (Domestic) crossings**

- 1.6.1.1 150mm of Type 1 sub-base to Clause 1.2. (NB where the CBR value of the sub- grade is below 1.5% an approved geosynthetic layer to Clause 6.7 will be required to be placed on the sub-grade). On certain sites the depth of topsoil may exceed 275mm. On such sites topsoil containing organic matter, roots, etc. shall be removed and replaced with Type 1 sub-base in accordance with Clause 1.2.
- 1.6.1.2 100mm of AC20 Dense Bin Rec Binder Course 40/60 or 100/150pen to Clause 9.1 compacted to a void content within the range 2%-10%.
- 1.6.1.3 25mm of AC6 Dense Surf Surface Course to Clause 9.4 compacted to a void content within the range 2%-10%.
- 1.6.1.4 The joint between the access crossing and the carriageway shall be formed with 125mm x 150mm precast concrete kerbs on a 150mm x 380mm base of ST4 (20N/mm<sup>2</sup>) concrete (approximately 1 cement: 2 sand: 4 aggregate by volume mix). A 125mm x 150mm x 225mm taper kerb will be required on each side of the crossing along the carriageway edge.
- 1.6.1.5 The highway boundary shall be delineated across the access crossing with 50mm x 150mm square cut precast concrete edging on a 75mm x 330mm base of ST4 (20N/mm<sup>2</sup>) concrete, and where there is no footway the edges of the access crossing shall also be delineated with the same edging and base (see figure 2/4).

### **1.6.2 Heavy Duty Vehicle Access Crossings**

- 1.6.2.1 The construction and thickness shall be the same as the adjacent carriageway with the proviso that in all cases the surface course shall be hot rolled asphalt to Clause 1.4. Radii kerbing shall be used each side of the crossing, dropped at the point of intersection with adjacent footways and tactile paving shall be provided each side when required (see figure 1/5).
- 1.6.2.2 Channel blocks, not dropped kerbs shall be used at the front of these crossings if channel blocks are installed along the adjacent carriageway and/or the adjacent carriageway is not surfaced with hot rolled asphalt. Channel blocks shall be installed at the rear of such crossings unless alternative restraint is available.

### **1.6.3 Small Block Pavers**

- 1.6.3.1 Small unit paver construction will be permitted for access crossings only when the adjoining footway is of that construction type. The materials utilised and thickness employed in the crossings shall be the same as the adjoining carriageway.

### **1.6.4 Vehicle Crossing over swale/filter drain**

- 1.6.4.1 Where a swale conveys surface water; within the swale, a 225mm diameter pipe at a minimum invert level of 600mm with a Type Z ST4 100mm concrete surround. A gradient of 1in60 fall towards the centre of the crossing in line with the swale. Standard construction around pipe and over swale with a flush channel block kerb along the carriageway edge (see Figure 1/4).
- 1.6.4.2 Where a swale/filter drain conveys surface water in an under drain pipe within 0.9m of the vehicle access construction, concrete protection is required as detailed in clause 5.15.8.

## **1.7 WAITING BAY OR LAY-BY CONSTRUCTION**

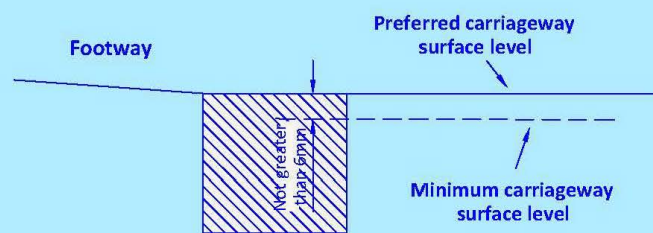
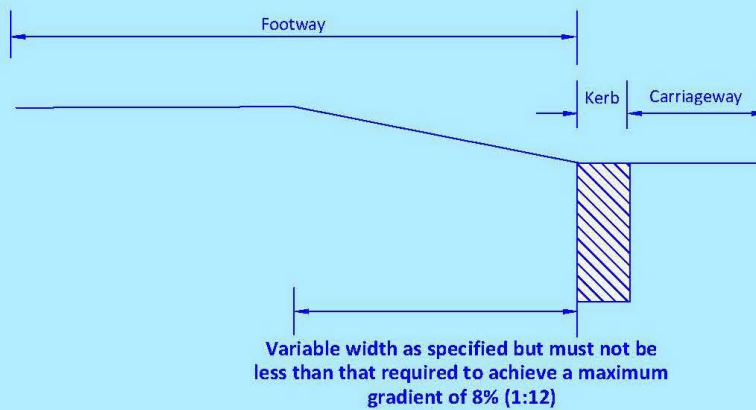
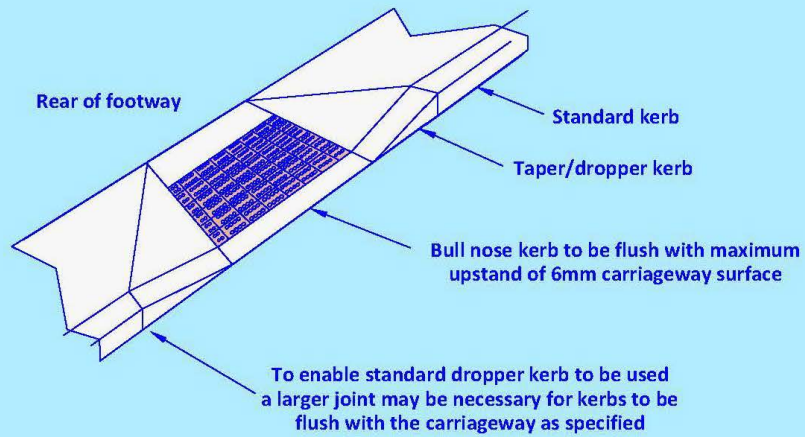
Construction shall normally be as for the adjoining carriageway.

## **1.8 TACTILE PAVING CROSSINGS FOR PEDESTRIANS**

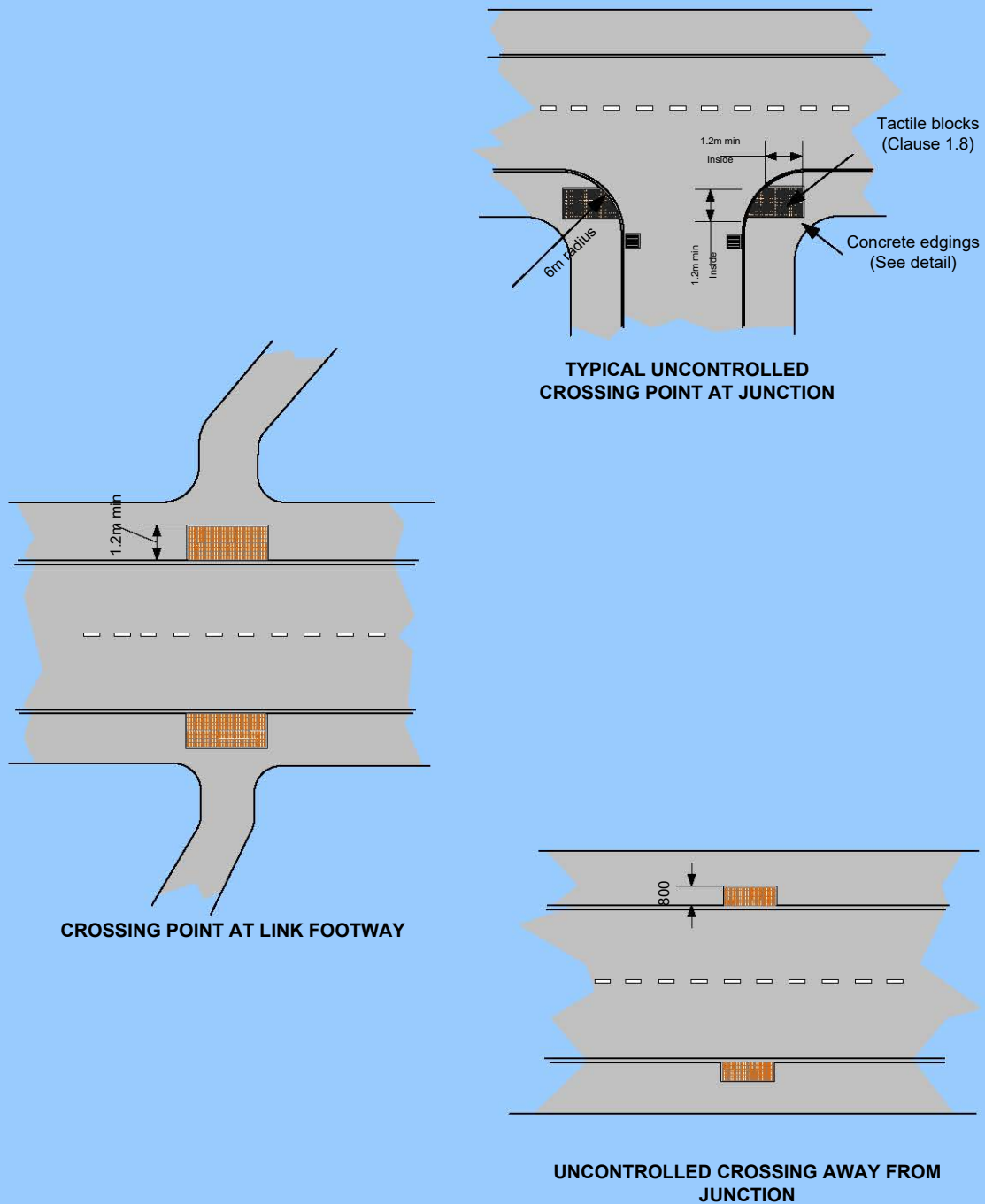
- 1.8.1 Blister tactile paving crossing points shall be provided at all junctions, crossings at link footways and at kerb to kerb flat top road crossings.
- 1.8.2 Tactile paving shall be 'dimple' high strength concrete blocks, 200mm x 133mm x 60mm paving blocks, with concrete edging around the outside of the blocks. The surface colour shall be buff.



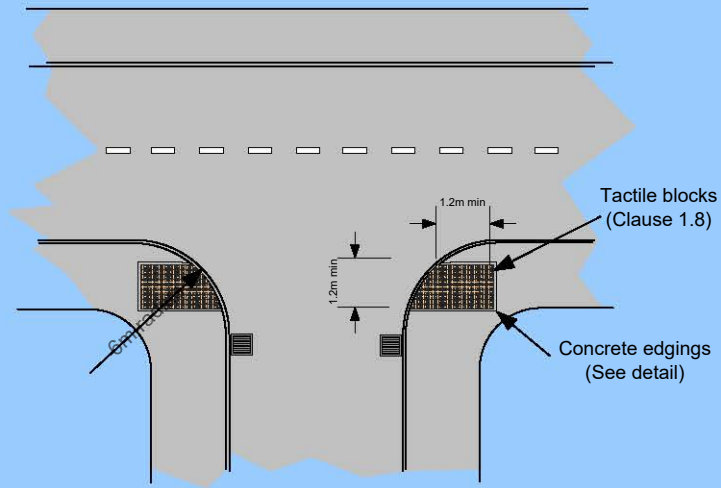
**FIGURE 1/6 - DROPPED KERB DETAIL AT CROSSING POINT**



**FIGURE 1/7 - USE OF TACTILE PAVING AT PEDESTRIAN CROSSING POINTS**

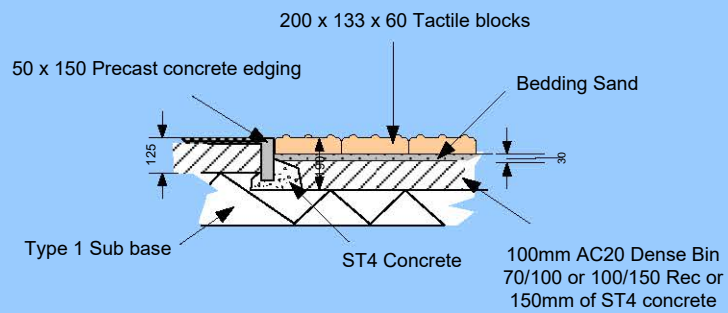


**FIGURE 1/8 TACTILE PAVING – TYPICAL DETAIL**



**NB** Tactile blocks should not encroach on the dropped kerbs

**TYPICAL UNCONTROLLED CROSSING POINT AT JUNCTION**



**CONCRETE EDGE DETAIL – TACTILE PAVING**

1.8.3 Tactile paving shall be installed in the line of travel, along a minimum of 1.2m of bull nose kerbs with a maximum of 6mm upstand. Flush kerbs to comprise 125mm x 150mm precast concrete channel blocks. The back edge of the tactile paving surface shall be at right angles to the direction of crossing

1.8.4 Developers shall take care not to locate service boxes (e.g. BT) where tactile paving is required.

## **1.9 SMALL BLOCK PAVERS**

1.9.1 Concrete blocks and clay pavers shall comply with Clause 10.2 and 10.3. They shall be laid in accordance with the requirements of BS 7533-3.

1.9.2 Herringbone bond pattern is required for all block paved areas other than when used as tactile paving. Only rectangular shaped blocks will be permitted.

1.9.3 The layout of blocks/pavers and details at edges, manholes, gullies and other openings shall be as recommended by the supplier and agreed with the Highway and Flood Authority in advance of laying.

Within the carriageway a 45 degree herringbone, double stretcher to the channel and single stretcher to iron work, accepting the fact that the pattern is lost around bends. Within the footways a 45 degree herringbone and single stretcher to the outer edges. A minimum of 1/3rd of a block cut will be required in all areas.

1.9.4 The developer may traffic the carriageway after the placement of the bituminous binder course across the full width of the carriageway provided that the thickness of the binder course is in accordance with the relevant Construction Chart.

1.9.5 When the block paver construction is to be completed prior to building being commenced then the thickness of the binder course layer quoted in Construction Chart 3 for roads up to 0.25 m.s.a. may be reduced to 60mm. The sub-base shall be correspondingly increased by 30mm in such cases.

1.9.6 Laying course (bedding) and jointing sand used in conjunction with small block pavers shall be in accordance with Clause 10.4.

## **1.10 CONSTRUCTION CHARTS**

1.10.1 Construction Charts 1 to 7 summarise the Highway and Flood Authority's structural requirements for adoptable carriageways.

Table 7, Pervious Pavement Block Paver Construction, includes the minimum thickness of Type 3 sub-base to meet structural requirements. Additional thicknesses of Type 3 sub-base to those given in Table 7 may be required to satisfy the hydraulic design requirements.

## CONSTRUCTION CHART 1 – NON PERVIOUS

### ROADS UP TO 0.25 msa. - NORMAL FLEXIBLE CONSTRUCTION

<b>SUB-GRADE</b> <i>Note 1</i>	<b>SUB-BASE (mm)</b>		<b>SURFACING (mm)</b>		<b>TOTAL THICKNESS REQUIRED (mm)</b>	
	Without geotextile	With geotextile	Binder Course <i>Note 4</i>	Surface Course	Without geotextile	With geotextile
Below 1½% and soft spots	<i>Not suitable</i>	710 <i>Notes 2 and 3</i>	130	40	<i>Not suitable</i>	880 <i>Notes 2,3 and 4</i>
1½%	<i>Not suitable</i>	440	130	40	<i>Not suitable</i>	610 <i>Note 4</i>
2%	400	340	130	40	570 <i>Note 5</i>	610 <i>Note 4</i>
3%	310	300	130	40	480 <i>Note 5</i>	510 <i>Note 4</i>
4% <i>Note 5</i>	300	300 <i>Note 5</i>	130	40	470 <i>Note 5</i>	470 <i>Note 4</i>
5% <i>Note 5</i>	300	300 <i>Note 5</i>	130	40	470 <i>Note 5</i>	470 <i>Notes 4 and 5</i>
6-15% <i>Note 5</i>	300	300 <i>Note 5</i>	130	40	470 <i>Note 5</i>	470 <i>Notes 4 and 5</i>
Above 15% <i>Note 5</i>	300	300 <i>Note 5</i>	130	40	470 <i>Note 5</i>	470 <i>Notes 4 and 5</i>

*Note 1* See Clauses 1.1.6, 1.1.7 and 1.1.8

*Note 2* See Clause 1.1.6 – Assumes no improvement is possible using either sub-soil drainage or soil strengthening technique. 710mm is 410mm of 6F5 Capping Layer Granular Fill to clause 6.8 and 300mm of Type 1 sub-base. The thickness of 710mm can be reduced to 620mm if all Type 1 sub-base is used.

*Note 3* For soft spots and sub-grades with a CBR of less than 1½% the geotextile shall be laid with an approved geogrid or shall be an approved geocomposite. Approved specialist design can be used with the agreement of the Authority.

*Note 4* Initial Binder Course layer thickness **70mm** if the **alternative kerbing installation method** (two stage construction – kerbing to be laid at a later stage) is used. **Total Binder Course thickness remains 130mm** in these circumstances. **See Clause 1.1.17.**

*Note 5* The use of a geosynthetic with a sub-grade with this bearing capacity offers no advantage or economy.

## CONSTRUCTION CHART 2 – NON PERVIOUS

ROADS UP TO 0.25 msa – MINIMUM DEPTH FLEXIBLE CONSTRUCTION  
(See Clause 1.1.18)

SUB-GRADE <i>Note 1</i>	SUB-BASE (mm)	SURFACING		TOTAL THICKNESS REQUIRED (mm)
Design CBR	Non-frost susceptible Type 1	Binder Course	Surface Course	When sub-grade is classified as frost susceptible
Below 1½% and soft spots	<i>Note 2</i>	200	40	<i>Note 2</i>
1½%	<i>Note 2</i>	200	40	<i>Note 2</i>
2%	150	200	40	390
3%	150	200	40	390
4%	150	200	40	390
5%	150	200	40	390
6-15%	150	200	40	390

*Note 1* See Clauses 1.1.6, 1.1.7 and 1.1.8

*Note 2* See Clauses 1.1.6 and 1.1.18

Requires at least 150mm Type 1 Sub-base plus an approved sub-soil strengthening technique.

### CONSTRUCTION CHART 3 – NON PERVIOUS

ROADS UP TO 0.25 msa. – BLOCK PAVER CONSTRUCTION  
(See Clause 1.9)

<b>SUB-GRADE</b> <i>Note 1</i>	<b>SUB-BASE (mm)</b>		<b>SURFACING (mm)</b>			<b>TOTAL THICKNESS REQUIRED (mm)</b>	
Design CBR	Without geotextile	With geotextile	Binder Course ( <i>Note 4</i> )	Laying Course	Block Paver	Without geotextile	With geotextile
Below 1½% and soft spots	<i>Not suitable</i>	710 <i>Notes 2and3</i>	90	30	60	<i>Not suitable</i>	890 <i>Notes 2and3</i>
1½%	<i>Not suitable</i>	440	90	30	60	<i>Not suitable</i>	620
2%	400	340	90	30	60	580	520
3%	310	300	90	30	60	490	480
4% <i>Note 5</i>	270	270 <i>Note 5</i>	90	30	60	450	450 <i>Note 5</i>
5% <i>Note 5</i>	270	270 <i>Note 5</i>	90	30	60	450	450 <i>Note 5</i>
6-15% <i>Note 5</i>	270	270 <i>Note 5</i>	90	30	60	450	450 <i>Note 5</i>
Above 15% <i>Note 5</i>	270	270 <i>Note 5</i>	90	30	60	450	450 <i>Note 5</i>

*Note 1* See Clauses 1.1.6, 1.1.7 and 1.1.8

*Note 2* See Clause 1.1.6 – Assumes no improvement is possible using either sub-soil drainage or soil strengthening technique. 710mm is 410mm of 6F5 Capping Layer Granular Fill to clause 6.8 and 300mm of Type 1 sub-base. The thickness of 710mm can be reduced to 620mm if all Type 1 sub-base is used.

*Note 3* For soft spots and sub-grades with a CBR of less than 1½% the geotextile shall be laid with an approved geogrid or shall be an approved geocomposite. Approved specialist design can be used with the agreement of the Authority.

*Note 4* See Clause 1.9

*Note 5* The use of a geosynthetic with a sub-grade with this bearing capacity offers no advantage or economy. Ref: BS7533 Guide for structural design of pavements constructed with clay or concrete block pavers.

## CONSTRUCTION CHART 4 – NON PERVIOUS

### ROADS UP TO 2.0 msa. – NORMAL FLEXIBLE CONSTRUCTION

<b>SUB-GRADE</b> <i>Note 1</i>	<b>SUB-BASE (mm)</b>		<b>SURFACING (mm)</b>		<b>TOTAL THICKNESS REQUIRED (mm)</b>	
Design CBR	Without geotextile	With geotextile	Binder Course <i>Note 4</i>	Surface Course	Without geotextile	With geotextile
Below 1½% and soft spots	<i>Not suitable</i>	710 <i>Notes 2 and 3</i>	180	40	<i>Not suitable</i>	930 <i>Note 2</i>
1½%	<i>Not suitable</i>	440	180	40	<i>Not suitable</i>	660
2%	400	340	180	40	620	560
3%	310	300	180	40	530	520
4% <i>Note 4</i>	260	260 <i>Note 4</i>	180	40	480	480 <i>Note 4</i>
5% <i>Note 4</i>	230	230 <i>Note 4</i>	180	40	450	450 <i>Note 4</i>
6-15% <i>Note 4</i>	230	230 <i>Note 4</i>	180	40	450	450 <i>Note 4</i>
Above 15% <i>Note 4</i>	230	230 <i>Note 4</i>	180	40	450	450 <i>Note 4</i>

*Note 1* See Clauses 1.1.6, 1.1.7 and 1.1.8

*Note 2* See Clause 1.1.6 - Assumes no improvement is possible using either sub-soil drainage or soil strengthening technique. 710mm is 410mm of 6F5 Capping Layer Granular Fill to clause 6.8 and 300mm of Type 1 sub-base. The thickness of 710mm can be reduced to 620mm if all Type 1 sub-base is used.

*Note 3* For soft spots and sub-grades with a CBR of less than 1½% the geotextile shall be laid with an approved geogrid or shall be an approved geocomposite. Approved specialist design can be used with the agreement of the Authority.

*Note 4* The use of a geosynthetic with a sub-grade with this bearing capacity offers no advantage or economy.



### CONSTRUCTION CHART 5 – NON PERVIOUS

ROADS UP TO 2.0 msa. - MINIMUM DEPTH FLEXIBLE CONSTRUCTION  
(See Clause 1.1.18)

SUB-GRADE <i>Note 1</i>	SUB-BASE (mm)	SURFACING (mm)		TOTAL THICKNESS REQUIRED (mm)
Design CBR	Non-frost susceptible Type 1	Binder Course	Surface Course	When sub-grade is classified as frost susceptible
Below 1½% and soft spots	<i>Note 2</i>	260	40	<i>Note 2</i>
1½%	<i>Note 2</i>	260	40	<i>Note 2</i>
2%	150	260	40	450
3%	150	230	40	420
4%	150	220	40	410
5%	150	210	40	400
6-15%	150	200	40	390

*Note 1* See Clauses 1.1.6, 1.1.7 and 1.1.8

*Note 2* See Clause 1.1.6

Requires at least 150mm Type 1 Sub-Base plus an approved sub-soil improvement technique

## CONSTRUCTION CHART 6 – NON PERVIOUS

### ROADS UP TO 2.0 msa. - BLOCK PAVER CONSTRUCTION

SUB-GRADE <i>Note 1</i>	SUB-BASE (mm)		SURFACING (mm)			TOTAL THICKNESS REQUIRED (mm)	
	Without geotextile	With geotextile	Binder Course	Laying Course	Block Paver	Without geotextile	With geotextile
Below 1½% and soft spots	<i>Not Suitable</i>	710 <i>Note 2</i>	120	30	80	<i>Not Suitable</i>	940 <i>Notes 2 and 3</i>
1½%	<i>Not Suitable</i>	440	120	30	80	<i>Not Suitable</i>	670
2%	400	340	120	30	80	630	570
3%	310	300	120	30	80	540	530
4% <i>Note 4</i>	260	260 <i>Note 4</i>	120	30	80	490	490 <i>Note 4</i>
5% <i>Note 4</i>	225	225 <i>Note 4</i>	120	30	80	455	455 <i>Note 4</i>
6-15% <i>Note 4</i>	220	220 <i>Note 4</i>	120	30	80	450	450 <i>Note 4</i>
Above 15% <i>Note 4</i>		220 <i>Note 4</i>					450 <i>Note 4</i>

*Note 1* See Clauses 1.1.6 and 1.1.7

*Note 2* See Clause 1.1.6 – Assumes no improvement is possible using either sub-soil drainage or soil strengthening technique. 710mm is 410mm of 6F5 Capping Layer Granular Fill to clause 6.8 and 300mm of Type 1 sub-base. The thickness of 710mm can be reduced to 620mm if all Type 1 sub-base is used.

*Note 3* For soft spots and sub-grades with a CBR of less than 1½% the geotextile shall be laid with an approved geogrid or shall be an approved geocomposite. Approved specialist design can be used with the agreement of the Authority.

*Note 4* The use of a geosynthetic with a sub-grade with this bearing capacity offers no advantage or economy. Ref:

BS7533 Guide for structural design of pavements constructed with clay or concrete block pavers.

## CONSTRUCTION CHART 7 – PERVIOUS

ROADS UP TO 0.25 msa. – PERVIOUS PAVEMENT BLOCK PAVER CONSTRUCTION  
(See Clause 1.9)

<b><i>SUB-GRADE</i></b> <small>Note 1</small>	<b>SUB-BASE (mm)</b>		<b>SURFACING (mm)</b>			<b>TOTAL THICKNESS REQUIRED (mm)</b>
	<b>Notes 2 &amp; 3</b>		Binder course ( <i>Note 4 &amp; 5</i> )	Laying Course ( <i>Note 6</i> )	Block Paver ( <i>Note 4</i> )	
Design CBR (soaked)	Minimum depth structural requirements	Additional Sub-base Depth Hydraulic Requirements				
3% <small>Note 7</small>	300	The additional depth of sub-base will be determined by hydraulic design.	130	50	80	The total thickness required will be dependent on both the structural <b>and</b> hydraulic thickness requirements for the sub-base.
4%	300		130	50	80	
5%	300		130	50	80	
6-15%	300		130	50	80	
Above 15%	300		130	50	80	

See overleaf for notes.

### **Notes to Construction Chart 7**

*Note 1* See Clauses 1.1.6, 1.1.7 1.1.8 and 1.1.9

*Note 2* Type 3 Open Graded sub-base to Clause 8.1

*Note 3* The total thickness of sub-base will be dependent on the additional thickness of sub-base to meet hydraulic design requirements.

*Note 4* See Clause 1.9

*Note 5* Binder course to be perforated by 75mm cores at 750mm centres.

*Note 6* See Clause 10.4

Ref: BS7533 Guide for structural design of pavements constructed with clay or concrete block pavers.

*Note 7* Construction Chart 6 roads shall not be used for sites with a subgrade soaked CBR value of less than 3%.

**2. TYPICAL SECTIONS THROUGH CARRIAGEWAY EDGE & FOOTWAY EDGE**

---

# FIGURE 2/1a, 2/1b & 2/1c - TYPICAL SECTIONS - CARRIAGEWAY AND FOOTWAY EDGE

FIGURE 2/1a - CHARTS 1,2,4,& 5 Type Roads

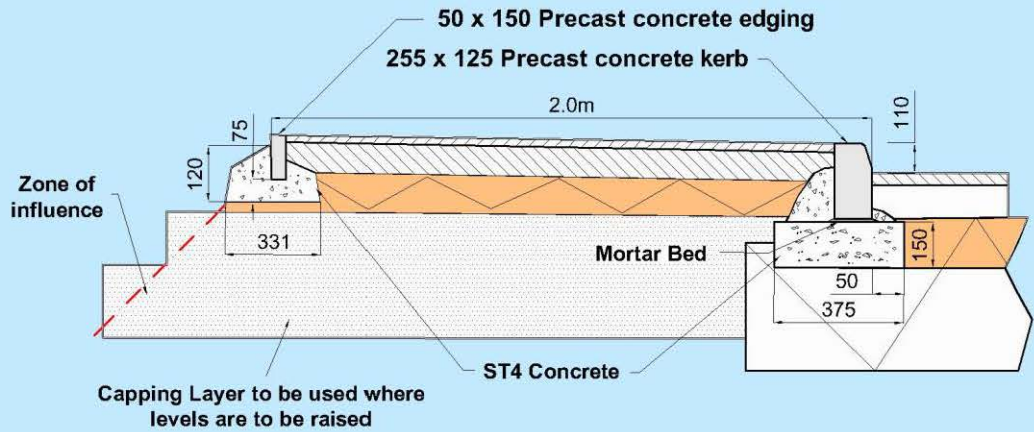


FIGURE 2/1b - CHART 3 & 6 Type Roads

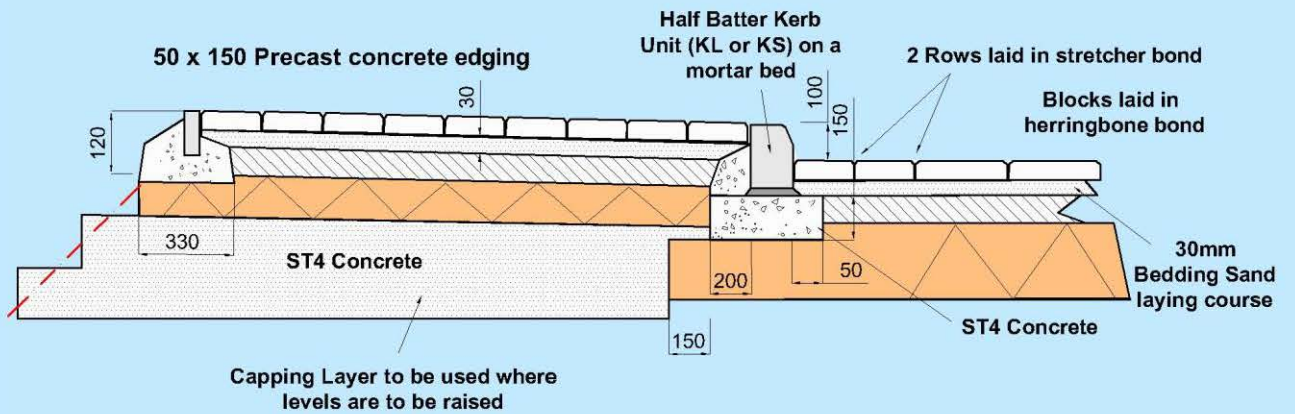
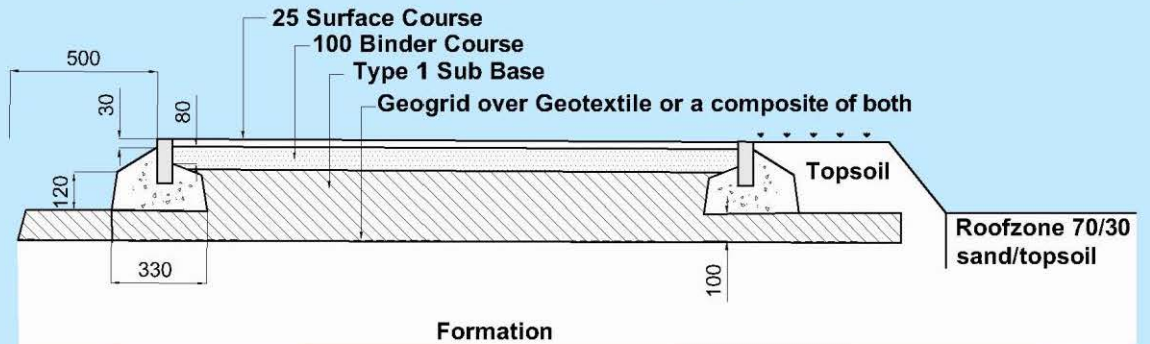
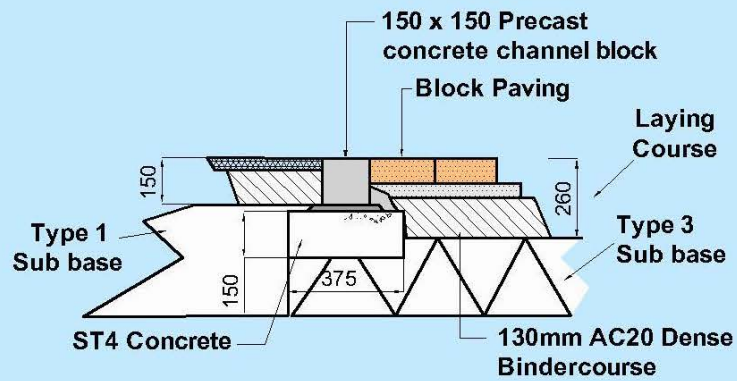


FIGURE 2/1c - Footway Construction Adjacent to Swale

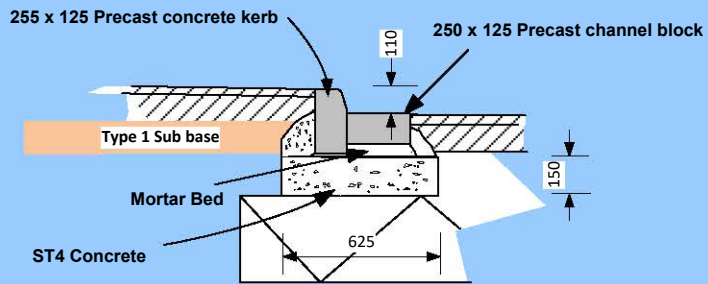


**Fig 2/2 TRANSITION – PERMEABLE PAVING TO TRADITIONAL CONSTRUCTION**

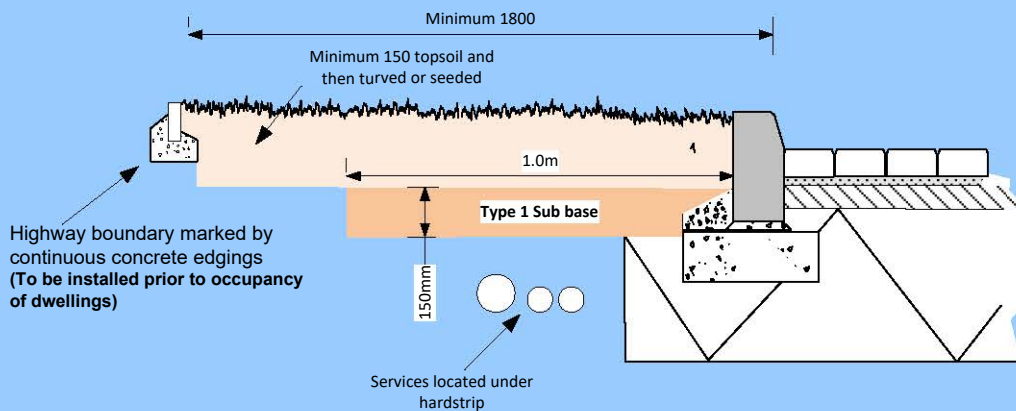


**FOR CARRIAGEWAY AND FOOTWAY DETAILS SEE SECTION 1 CHARTS 1 TO 6**

**FIGURE 2/3 - CHANNEL BLOCK AND KERB DETAIL**



**FIGURE 2/4 – SERVICE MARGIN DETAIL – SHARED SURFACE**



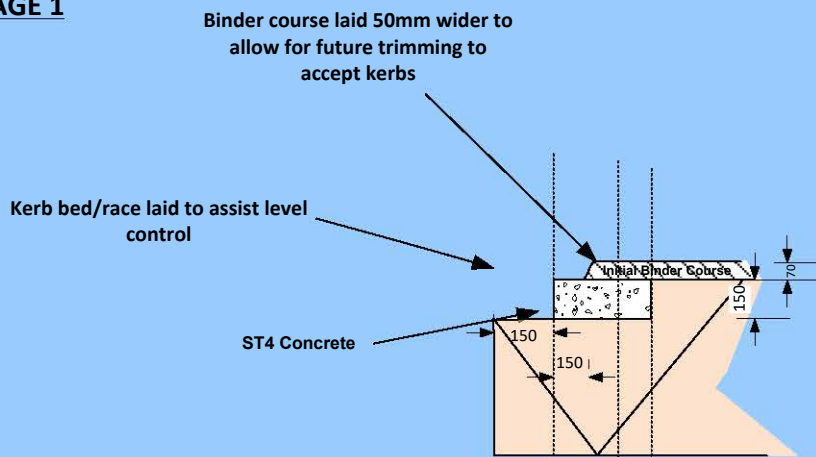
**Note**

Machine laid kerb race may be installed with a notched profile

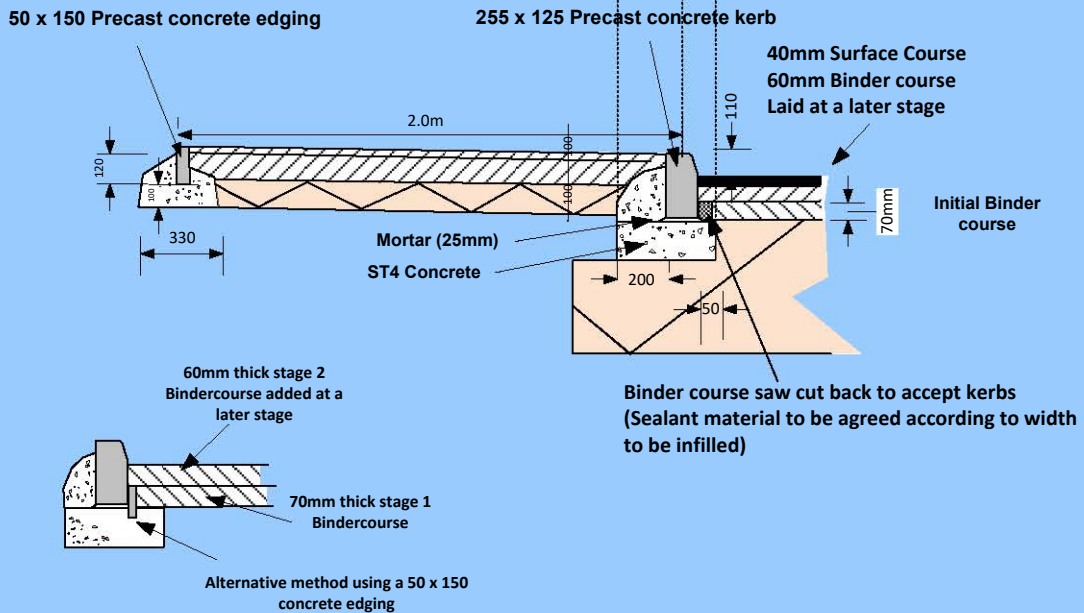


**FIGURE 2/5 - Chart 1 Type Road Utilising Alternative Method Of Kerb Installation  
(Two stage construction; kerbing to be added at a later stage)**

**STAGE 1**

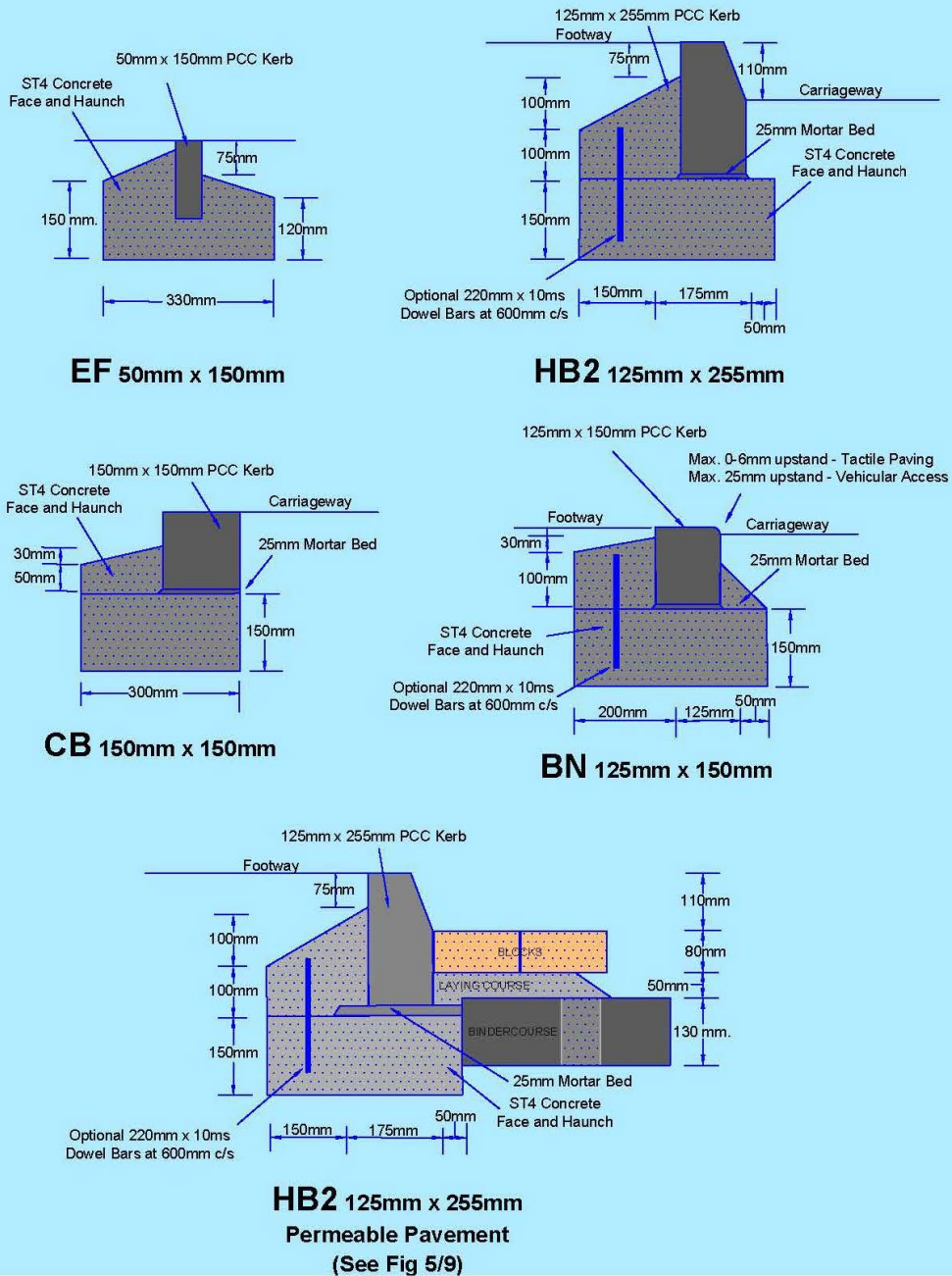


**STAGE 2**



**FOR CARRIAGEWAY AND FOOTWAY DETAILS SEE SECTION 1 CHARTS 1 TO 6**

## FIGURE 2/6 - KERBING DETAILS



### **3. TRAFFIC AND SAFETY MEASURES DURING CONSTRUCTION**

---

#### **3.1 TEMPORARY TRAFFIC SIGNS**

- 3.1.1 The Developer shall erect and maintain on the site and on the approaches to the site all traffic signs and traffic control signals necessary for the direction and control of traffic. The signs shall conform to the current Safety at Street Works and Road Works Code of Practice and where applicable The Traffic Signs Manual Chapter 8 "Traffic Safety Measures and Signs for Roadworks and Temporary Situations". The signs shall be reflectorised and kept clean and legible.
- 3.1.2 All temporary traffic signs used require the prior approval by the Highway and Flood Authority. Where unauthorised signs and/or fly posting etc. takes place the Highway and Flood Authority will take appropriate enforcement action to rectify the situation.

#### **3.2 CONTROL OF TRAFFIC**

- 3.2.1 Any off site excavations to be carried out in the existing public highway will require the Developer to provide the Highway and Flood Authority with accurate and timely information relating to works they are planning to carry out, as outlined under the New Roads and Street Works Act 1991 (NRSWA) and/or the Highways Act 1980.

Details of the works, including the nature, location and timing of the works must have prior agreement with the Highway and Flood Authority before starting any works. Any activity that has the potential to cause delay or disruption or any works that involves breaking up the existing highway are deemed permissible works. Lincolnshire County Council became a permissible authority on 5<sup>th</sup> October 2016. Any promoter as prescribed in the Regulations who wishes to perform or carry out an activity must first obtain a permit from Lincolnshire Highways. This permits the promoter to carry out the specified activity, at the specified location, between the dates shown and agrees the conditions which may be attached.

Permission will only be granted by the Highway and Flood Authority once the Developer has signed and completed the Section 38 Agreement. Should the developer enter into the existing highway in advance of this, then their excavation will be considered illegal interference with the highway and appropriate enforcement action may be instigated.

All supervisors and operatives working within the highway are required to hold a valid accreditation qualification as laid out in The Street Works (Qualification of Supervisors and Operatives) England, Regulations 2009. The Developer or Contractor carrying out the works must hold a valid £10million or greater liability insurance certificate.

All works conducted within the public highway must be carried out and completed to the satisfaction of the Highway and Flood Authority to comply with the requirements of the NRSWA.

Any works within the existing highway related to Trunk Roads, you must seek approval from Highways England.

- 3.2.2 Where traffic signals are required, a minimum of two weeks' notice is also required from the Highway and Flood Authority. For Trunk Roads this notice is extended to six weeks and approval is required from Highways England.

### **3.3 TEMPORARY DIVERSION OF TRAFFIC**

- 3.3.1 The Developer shall construct temporary diversion ways wherever the works will interfere with existing public or private roads or other ways over which there is a public or private right or way for any traffic, including pedestrians. Any diversion shall be suitable in all respects for the type and volume of traffic requiring to use it. It shall be constructed in advance of taking up the existing way and regularly maintained. Developers are reminded of the statutory three months' notice (13 weeks) required to obtain a road closure.

### **3.4 SAFETY CODES**

- 3.4.1 The Developer shall comply with the current Safety at Street Works and Road Works Code of Practice and where applicable The Traffic Signs Manual Chapter 8 "Traffic Safety Measures and Signs for Roadworks and Temporary Situations" and all of the relevant current safety standards.

### **3.5 EXCAVATIONS**

- 3.5.1 The Developer shall ensure that all excavations on the site and on the approaches to the site are adequately signed, fenced and supported.

### **3.6 MATERIALS ON THE HIGHWAY**

- 3.6.1 No building materials etc. shall be stored on the public highway, without the permission of the Highway and Flood Authority. Care should also be taken not to impede visibility at junctions through the inappropriate storage of materials on site.

### **3.7 MUD, ETC., ON THE HIGHWAY**

- 3.7.1 Developers are reminded that under the Highways Act 1980, they are responsible for ensuring that the existing public highway is kept clear from mud, stones, silt, etc. at all times.
- 3.7.2 Every effort should also be made to keep sites, where dwellings are occupied, in a safe and tidy condition.

### **3.8 WIDE LOADS**

- 3.8.1 Where works affect the public highway and cause a reduction in width to that highway, possible conflicts may occur regarding the movement of abnormal loads. Therefore, if the works involve the reduction in carriageway width to less than 4.1m, or the width between street furniture (or other obstructions) above kerb level to less than 6.0m, the Abnormal Load Officer must be notified of the changes. The above dimensions apply to straight or near straight roads and these values need increasing on sharp bends or roundabouts.
- 3.8.2 This guidance applies to all temporary and permanent works, affecting classified and unclassified roads.

## 4. SITE CLEARANCE

---

### 4.1 CLEARING SITE

- 4.1.1 Trees, stumps and tree roots within the proposed highway shall be removed. Holes left by the demolition of buildings, by uprooting trees etc., shall be filled in accordance with Clause 6.1.1.

## **5. DRAINAGE and SuDS**

---

### **5.1 CONNECTIONS TO EXISTING DRAINS OR PUBLIC SEWERS**

- 5.1.1 Before entering or breaking into an existing sewer or drain, the Developer must obtain the permission of the Authority responsible for the pipeline or watercourse to which the connection is to be made.
- 5.1.2 Where excavation within the existing public highway is necessary, the permission of the Highway and Flood Authority must be obtained and a permit to work in the highway under the New Records and Streetworks Act must be obtained from the Highway and Flood Authority. In addition to the Permit (section 50 licence) the Developer (work promoter) must give the relevant notification for the works under the Traffic Management Act 2004. The minimum notification periods are subject to the duration of the works.
- 5.1.3 Notice needs to be taken of the Undertaker's or Highway and Flood Authority's health and safety procedures for working in public sewers or existing highway drainage systems.

### **5.2 Not used**

### **5.3 PIPES, COUPLINGS, FITTINGS and ANCILLARY PRODUCTS**

- 5.3.1 Pipes/conduits greater than 600mm diameters are classed as highway structures and therefore Section 11 of this Specification applies.  
One type of pipe shall be used between manholes and catchpits. All pipes and joints shall be jointed in accordance with the manufacturer's instructions.

#### Vitrified Clay Pipes and Fittings

- 5.3.2 Vitrified clay pipes and fittings shall have flexible mechanical joints. Pipes shall comply with the relevant requirements of BS EN 295 and BS 65 (surface water pipes only).

#### Concrete Pipes and Fittings

- 5.3.3 Unreinforced and reinforced concrete pipes and fittings with flexible joints shall comply with the relevant provisions of BS EN 1916:2002 and BS5911-5:2004 + A1:2010.
- 5.3.4 All pipes and fittings shall have gasket-type joints of spigot and socket or rebated form, unless otherwise agreed with the Highway and Flood Authority.
- 5.3.5 Particular requirements from the options listed in Appendix A of BS 5911: Part 100 should be shown on the Drawings.

#### Ductile Iron Pipes and Fittings (Highway Authority approval required)

- 5.3.6 Ductile iron pipes and fittings shall comply with the relevant provisions of BS EN 598.
- 5.3.7 Ductile iron pipelines shall be designed and installed in accordance with the manufacturer's instructions.
- 5.3.8 The internal lining of the pipe, if necessary, shall resist attack by contaminants typically found in highway surface water runoff.

- 5.3.9 The Developer will provide independent soil contamination and resistivity data to determine the required external anti corrosion coating for the pipes and type of pipe seal.

Thermo plastic structured twin wall pipes and fittings

- 5.3.10 Thermo plastic structured twin wall pipes and fittings shall comply with the relevant provisions of BS EN 13476-1, WIS 4-35-01 and BS EN 13476-2 or BS EN 13476-3. Pipes shall be BSi Kitemarked or have equivalent Third Party Certification.
- 5.3.11 Pipes less than or equal to 500 mm in diameter shall have nominal short-term ring stiffness not less than 8 kN per m<sup>2</sup> (SN8) or be subject to a quality system for storage and embedment.
- 5.3.12 Nominal short-term ring stiffness of 2 kN per m<sup>2</sup> (SN2) is acceptable for pipes greater than 500 mm in diameter, subject to structural design load calculations which shall be provided to support this.
- 5.3.13 Where a fitting is installed on a sewer length, it shall have the same internal bore as the sewer. Maximum length of pipe for laying is 3 m or 10 x DN, whichever is the greater, unless welded joints are used.
- 5.3.14 The maximum permitted internal diameter is 450mm. The minimum depth of cover permitted is 1.2m. With structural calculations this may be reduced to 0.9m.
- 5.3.15 Only single pipe in trench arrangements are permitted.
- 5.3.16 Only proprietary fittings and accessories shall be used in the pipeline unless otherwise approved in writing by the pipe manufacturer.
- 5.3.17 The pipes shall be transported, handled, stored and laid in accordance with the manufacturer's recommendations.
- 5.3.18 Pipes shall be black in colour and have a smooth internal bore.
- 5.3.19 Pipes used for filter drains shall incorporate slots and have a minimum cross sectional area of 1000mm<sup>2</sup> per metre run of pipe.

Other Materials

- 5.3.20 Other materials will be considered on a site specific basis.
- 5.3.21 The Developer will be expected to provide all necessary technical information and design calculations required by the Highway and Flood Authority. Where the Highway and Flood Authority deems it necessary the Developer will be responsible for independent technical checks and testing.

Linear and Combined Kerb Drainage

- 5.3.22 Linear and Combined Kerb Drainage systems are only permitted with prior approval from the Highway and Flood Authority.

### Flexible Couplings

- 5.3.23 Flexible couplings shall comply with the provisions of WIS 4-41-01 and BS EN 295-4.

### Vortex Flow Control (VFC) Devices

- 5.3.24 The use of a flow control device is subject to the approval of the Highway and Flood Authority. They shall be self-cleaning and require no power input or have any moving parts and have a bypass door fitted which can be operated at cover level. The Highway and Flood Authority may request a high level overflows or ancillary drain down device.
- 5.3.25 Flow control devices shall be constructed of grade 316S31 stainless steel and installed using Grade 316S31 stainless steel fixings all in accordance with BS970 Part 1, BS ENs 10084, 10085, 10087, 10088, 10095 and 10250-4.
- 5.3.26 The minimum aperture shall be 75mm and have a design flow greater than 4l/s.
- 5.3.27 Precast or preformed flow control device chambers are preferred by the Highway and Flood Authority provided the access requirements in Table 5/2 can be met. Where the highway drain layout or access requirements do not permit this then in-situ flow control device chambers shall be design in accordance with the following criteria:
- 5.3.28 The design of the flow control device chamber shall be to direct the incoming flow to the flow control device intake with minimal turbulent flow.
- 5.3.29 The VFC make and model submitted for approval shall be the one used in the hydraulic design calculations and installed on site. Any change to the specified device shall be resubmitted for approval prior to being installed on site. Four weeks notice may be required to grant approval.
- 5.3.30 Flow control devices should have a free discharge. Where it is not practicable to achieve a free discharge at all times, attenuation calculations showing both the free discharge and surcharge conditions shall be submitted for approval.
- 5.3.31 Access openings into VFC chambers shall be of sufficient size to allow the removal and replacement of the proposed VFC device.
- 5.3.32 The flow control device chamber shall be approved by the flow control device supplier.
- 5.3.33 The flow control device chamber shall contain a sump to act as a catchpit.
- 5.3.34 The Developer shall submit a site specific design and specification sheet provided by the manufacturer of the flow control device for the development in question. The design shall clearly indicate the suitability of the flow control device for intended purpose. Generic designs and specifications are not permitted.

### Orifice Plates

- 5.3.35 The use of orifice plates is subject to the prior approval of the Highway and Flood Authority. The minimum aperture shall be 75mm. Orifice plates will not be accepted as the final outlet from any drainage system. Orifice plates shall be proprietary products made from Grade 304 stainless steel with an EDPM or equivalent seal. They shall be mounted and fixed in accordance with manufactures recommendations. Orifice plates shall be designed and installed so as to prevent detritus and silt build up.



### Throttle Pipes

- 5.3.36 The use of throttle pipes is subject to the prior approval of the highway and Flood Authority. The minimum pipe size acceptable is 150mm. Throttle pipes will not be accepted as the final outlet from any drainage system.

### Ancillary Devices (Penstocks, Flap valves etc.)

- 5.3.37 The Developer shall seek the approval of the Highway and Flood Authority before incorporating any ancillary devices within the highway drainage system. Ancillary devices will comply with the relevant European or British Standard or have third party accreditation.
- 5.3.38 Ancillary devices will not require any energy input, or have any mechanical parts, except where absolutely necessary, and they shall be virtually maintenance free.
- 5.3.39 Ancillary devices shall be installed in accordance with the manufacturer's instructions. All fixings shall be Grade 316S31 stainless steel fixings all in accordance with BS970 Part 1, BS ENs 10084, 10085, 10087, 10088, 10095 and 10250-4.

## **5.4 MANHOLES**

- 5.4.1 Figures 5/1 to 5/4 show typical details of manholes with depths from cover level to soffit of pipe not exceeding 6m. No significant departure from these shall be made without approval by the Highway and Flood Authority. However, in special circumstances where there is a significant risk of high levels of detritus entering the drainage system catchpit manholes may be specified by the Highway and Flood Authority. Manholes should be designed and constructed in accordance with BS EN 752-3.
- 5.4.2 Manhole diameters (Type A and B only) should be in accordance with Table 5/2 below:

**Table 5/2**

<b>Diameter of largest pipe in manhole (mm)</b>	<b>Internal diameter of manhole (mm)</b>
Less than 375	1200 (1050 where depth to soffit is 1.35 m –
375 – 700	1.5m) 1500
750 – 900	1800
Greater than 900	Consult Highway and Flood Authority

- 5.4.3 The internal diameters quoted above are considered to be the minimum. Where two or more pipes enter the manhole, the internal diameter may have to be increased to accommodate the minimum width of benching. Pipes of different diameters entering manholes should be installed with soffits at the same level.
- 5.4.4 The height of a Type A manhole (benching to slab soffit) should normally be in excess of 2000mm. When this is impracticable, Type B manholes are preferred subject to an absolute minimum height (benching to slab soffit) of 900mm.

- 5.4.5 The dimensions of Types C and D manholes should be as shown on Figures 5/3 and 5/4.

#### Precast Concrete Manholes

- 5.4.6 Precast concrete manhole units of circular cross-section for manholes shall comply with the relevant provisions of BS EN 1917:2002 and BS 5911-3:2010 + A1:2014. Units which bed into bases shall be manufactured so that imposed vertical loads are transmitted directly via the full wall thickness of the unit. For joints between units and the underside of slabs, joint profiles shall be capable of withstanding applied loadings from such slabs, and spigot-ended sections shall only be used where the soffit of the slab is recessed to receive them.
- 5.4.7 Precast concrete sections for manholes shall be constructed with steps and slab, rungs aligned correctly.
- 5.4.8 The jointing material for precast units shall be mortar or a proprietary bitumen or resin mastic sealant, with the concrete surfaces prepared in accordance with the manufacturer's recommendations.
- 5.4.9 Joints shall be made so that the required jointing material fills the joint cavity. Any surplus jointing material which is extruded inside the manhole shall be trimmed off and joints shall be pointed on completion.
- 5.4.10 Concrete surrounds to manholes and chambers shall be C16/20 and the height of each concrete pour shall not exceed 2m. Each construction joint shall break joint with the precast sections by at least 150mm.

#### Step Rungs

- 5.4.11 Step rungs in accordance with BS EN 13101:2002 shall be provided in all manholes (except Type D) at 300mm intervals. They shall be of galvanised mild steel or plastic encapsulated type.

#### Ladders

- 5.4.12 Mild steel ladders for vertical fixing shall comply with the relevant provision of BS 4211, Class A and PD970. After fabrication, mild steel ladders shall be hot dip galvanised in accordance with BS EN ISO 1460.
- 5.4.13 Stainless steel ladders for vertical fixing shall be fabricated from Grade 316S31 steel complying with BS970: Part 1 and BS EN 10085, BS EN 10085, BS EN 10087, BS EN 10095, BS EN 10250, BS EN 10029, BS EN 10048, BS EN 10051, BS EN 10258 or BS EN 10259.

#### Safety Chains

- 5.4.14 Safety chains shall be provided in manholes where the outgoing pipe exceeds 600mm diameter. Safety chains shall be installed in accordance with Figure 5/5.
- 5.4.15 Safety chains shall be mild or stainless steel. After manufacture, mild steel safety chains shall be hot dip galvanised in accordance with BS EN ISO 1460 and BS EN ISO 1461.
- 5.4.16 Mild steel safety chain shall be 8mm nominal size Grade M(4) non calibrated chain, Type 1, complying with BS EN 818-1.

- 5.4.17 Stainless steel safety chains shall be manufactured from Grade 316S31 steel complying with BS 970: Part 1. Chain links shall be welded and have an internal length not exceeding 45mm and an internal width of 12mm and 18mm. The fins caused by welding shall be removed and the weld shall be smoothly finished all round.
- 5.4.18 When tested in accordance with BS EN 818-1, each chain shall withstand a breaking force of 30kN and a proof force of 15kN.

High Strength Concrete Topping to Inverts and Benching

- 5.4.19 Inverts and benchings in manholes shall have a screeded, ridged finish and shall have a smooth, high strength concrete topping applied to a ridged screed finish. This topping shall be brought to a dense and smooth finish with a steel trowel.
- 5.4.20 High strength concrete topping shall be produced, laid and finished in accordance with the relevant provisions of BS 8204-2 and the following approximate mix proportions by weight shall be used: one part cement, one part natural sand and two parts single sized coarse aggregate.
- 5.4.21 Aggregates for high strength concrete topping (granolithic finish) shall comply with BS EN 12620, D=10mm, graded in accordance with Table 2 of that Standard.

Access to inverts greater than 600mm diameter

- 5.4.22 Where the pipe diameter is greater than 600mm access into the channel shall be provided in accordance with Figure 5/6a.

Rocker Pipes

- 5.4.23 A flexible joint shall be provided as close as is feasible to the outside face of any manhole into which a pipe is built. The design of the joints shall be compatible with any subsequent movement.
- 5.4.24 The recommended length of the next pipe (rocker pipe) away from the manhole should be as shown in Table 5/3 below:

**Table 5/3**

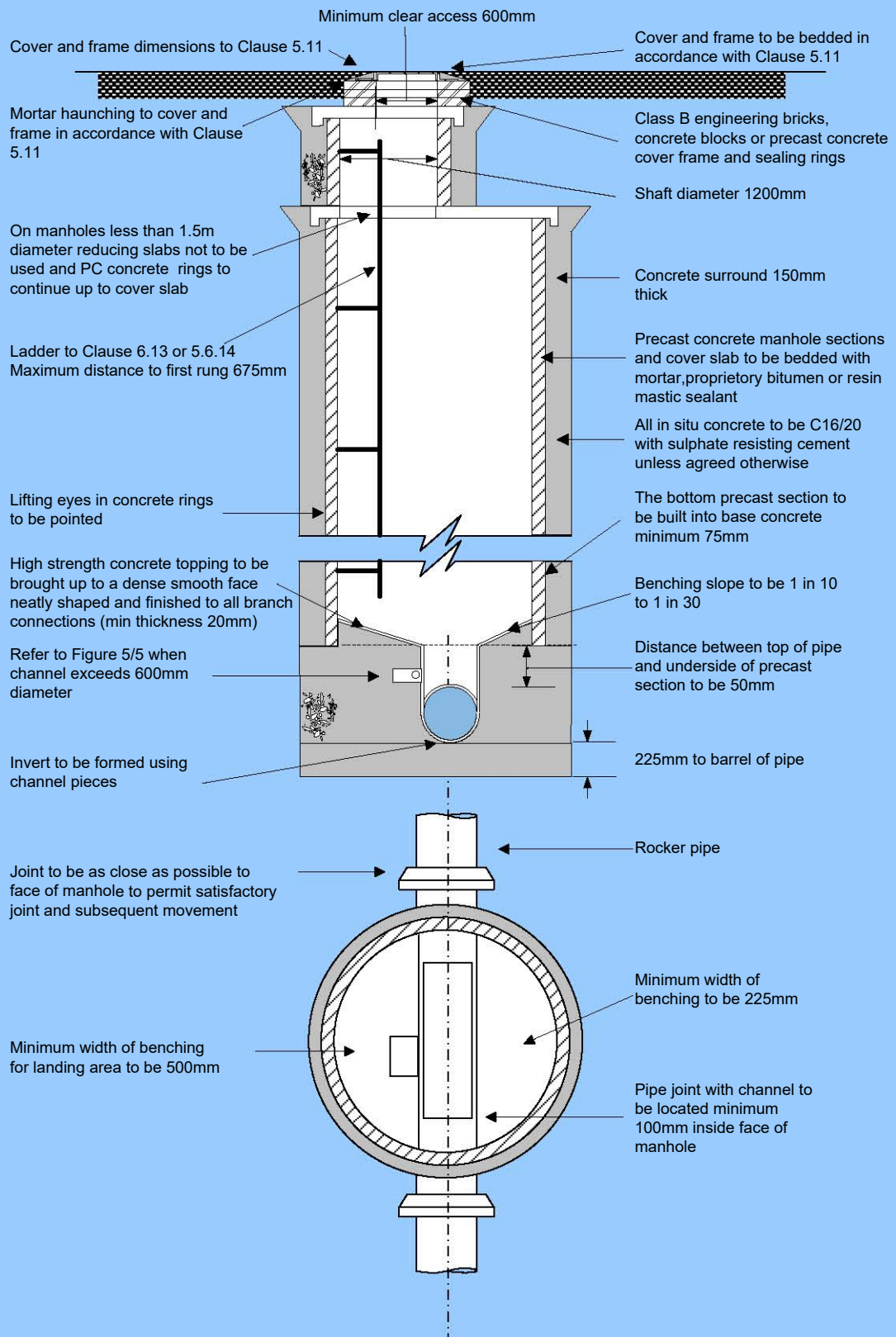
Nominal Diameter (mm)	Effective Length (m)
150 to 600	0.6
675 to 750	1.0
Over 750	1.25

Stub pipes into manholes shall be of rigid material.

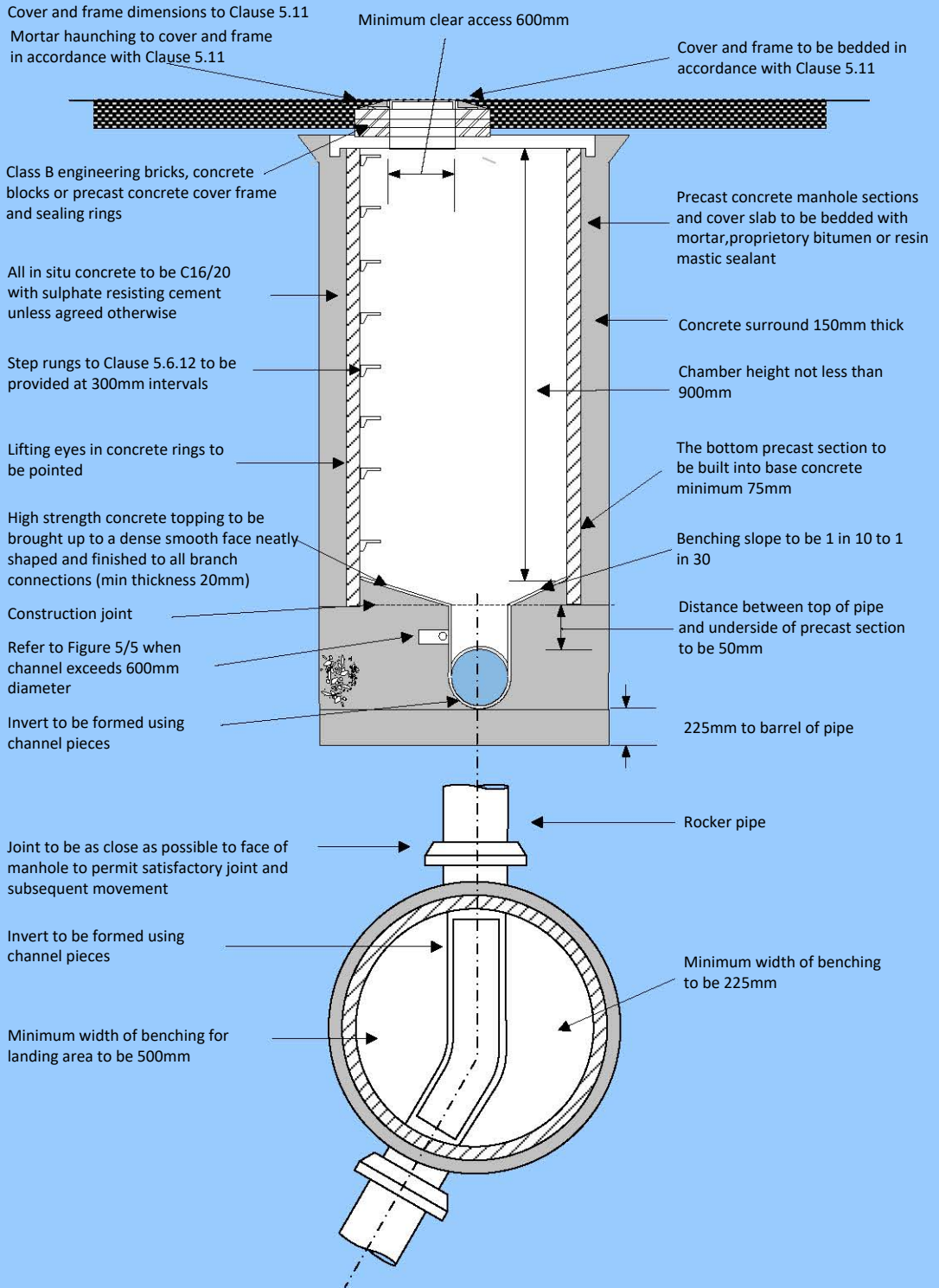
Warning Signs

- 5.4.25 Warning signs shall be located in the upstream, downstream and actual manholes containing ancillary devices and structures i.e. flow control devices, storm water tanks etc.
- 5.4.26 The signs shall be designed in accordance with BS 5499-1:2002 utilising sign reference BS EN ISO 7010:2012 + A5:2015 with supplementary text specific to the hazard and agreed by the Highway and Flood Authority.
- 5.4.27 The signs shall be manufactured from materials that are not adversely affected by the environment and effluent typically found in surface water sewer systems. The signs shall be clearly legible for a minimum of 10 years.
- 5.4.28 The signs shall be mechanically fixed within the manhole where they can be clearly read without entering the chamber and in a position where they will not hinder access into the chamber. The fixing position shall be agreed with the Highway and Flood Authority. The fixings shall be Grade 316S31 stainless steel in accordance with BS970 Part 1, BS ENs 10084, 10085, 10087, 10088, 10095 and 10250-4.

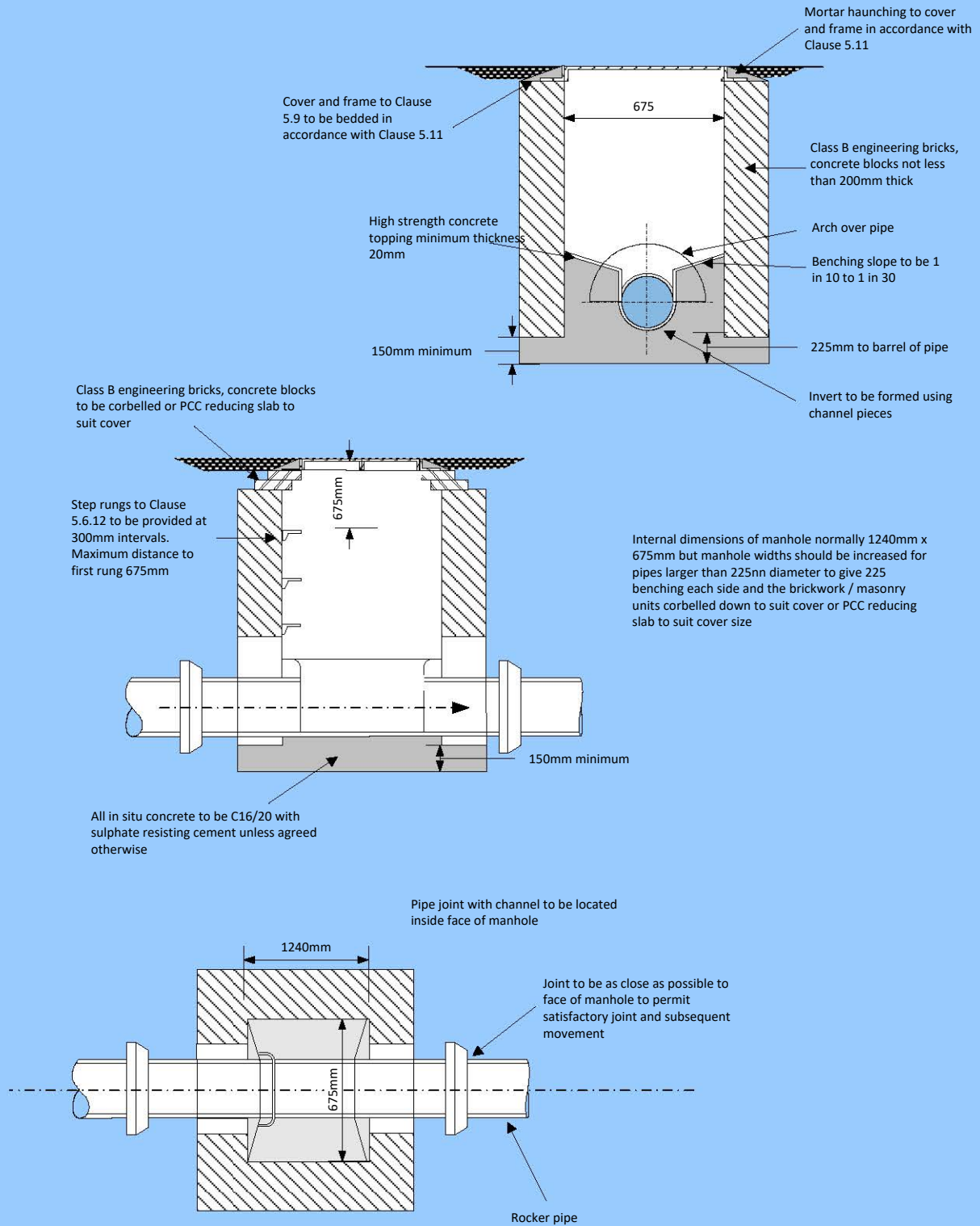
**FIGURE 5/1 - TYPICAL MANHOLE DETAIL - TYPE A**  
**Depth from cover level to soffit of pipe 3m to 6m**



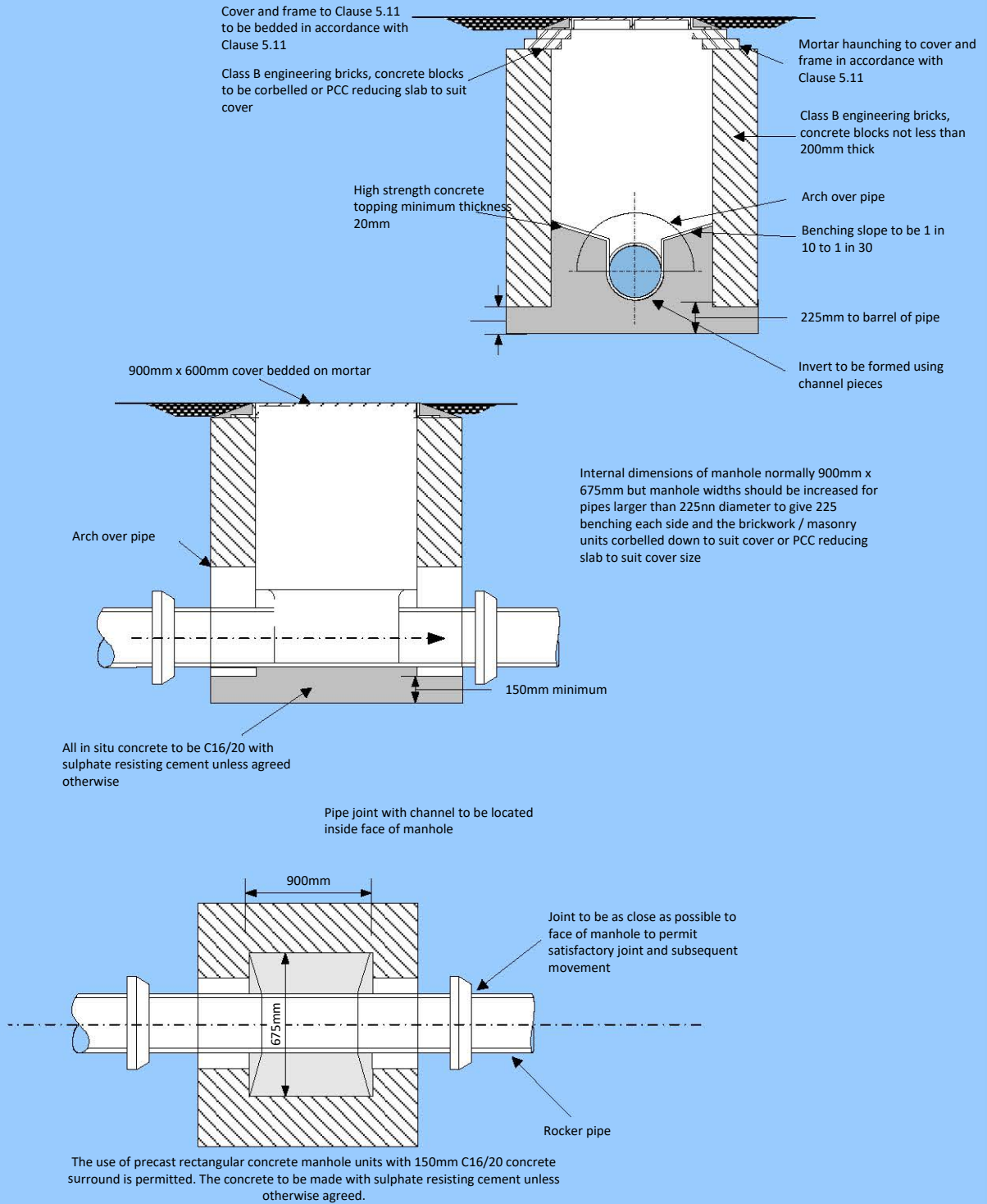
**FIGURE 5/2 - TYPICAL MANHOLE DETAIL - TYPE B**  
**Depth from cover level to soffit of pipe up to 3m**



**FIGURE 5/3 - TYPICAL MANHOLE DETAIL - TYPE C**  
**Depth from cover level to soffit of pipe 1.0m to 1.5m**

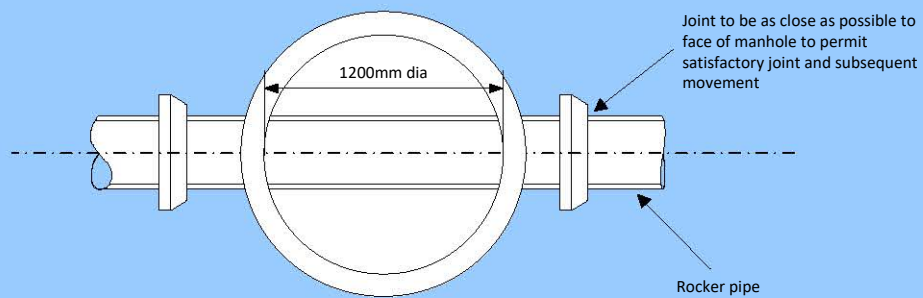
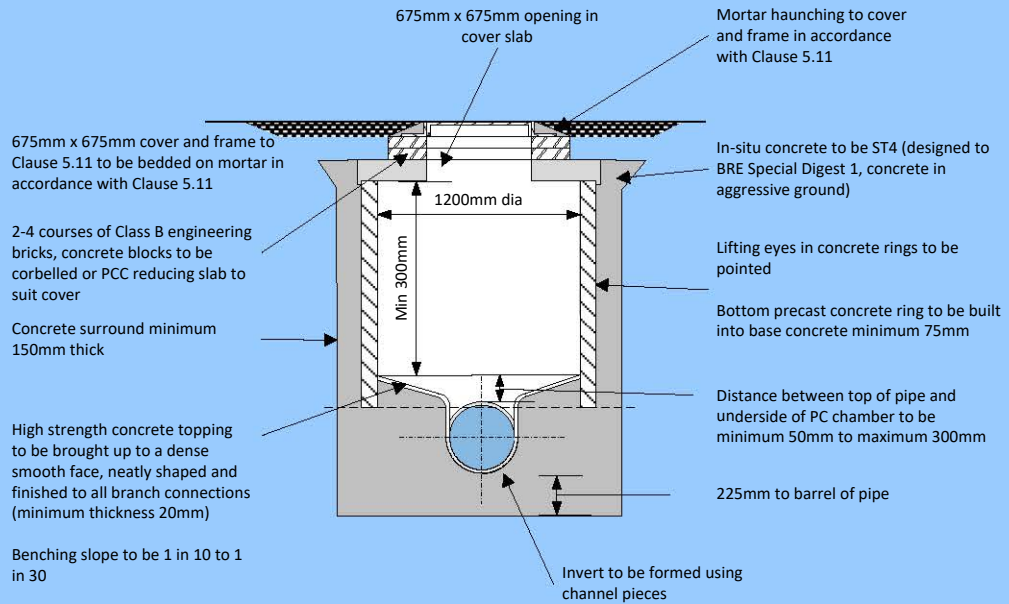


**FIGURE 5/4 - TYPICAL MANHOLE DETAIL - TYPE D**  
**Depth from cover level to soffit of pipe less than 1.0m**

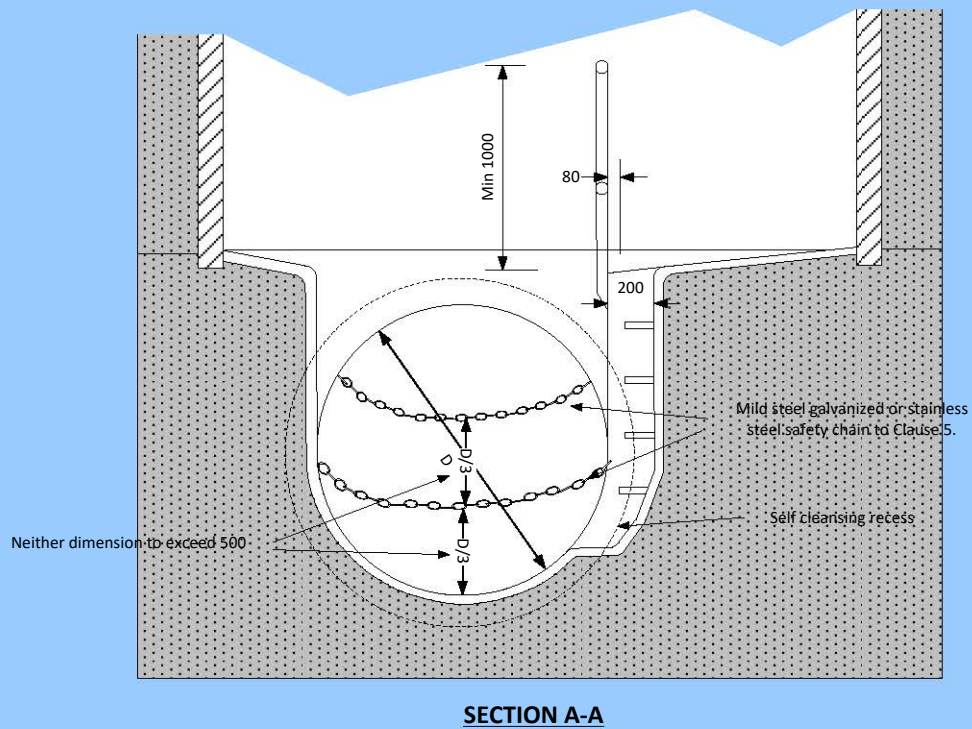
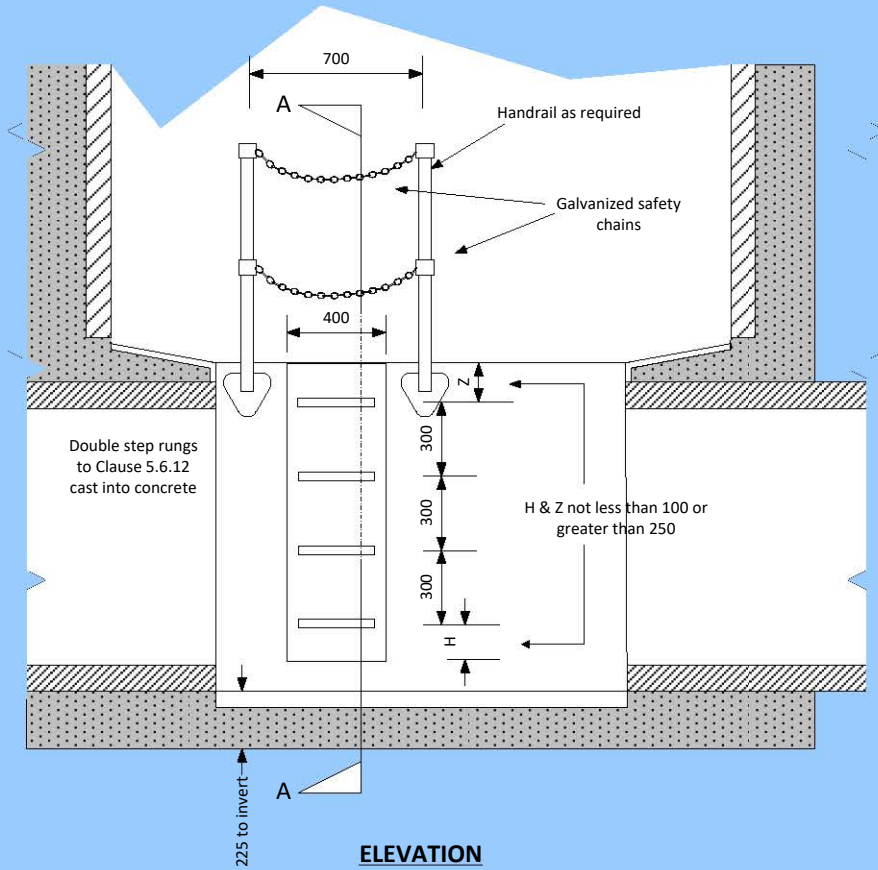




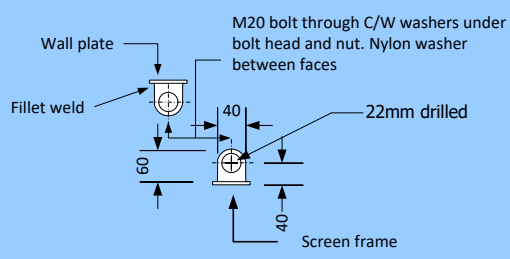
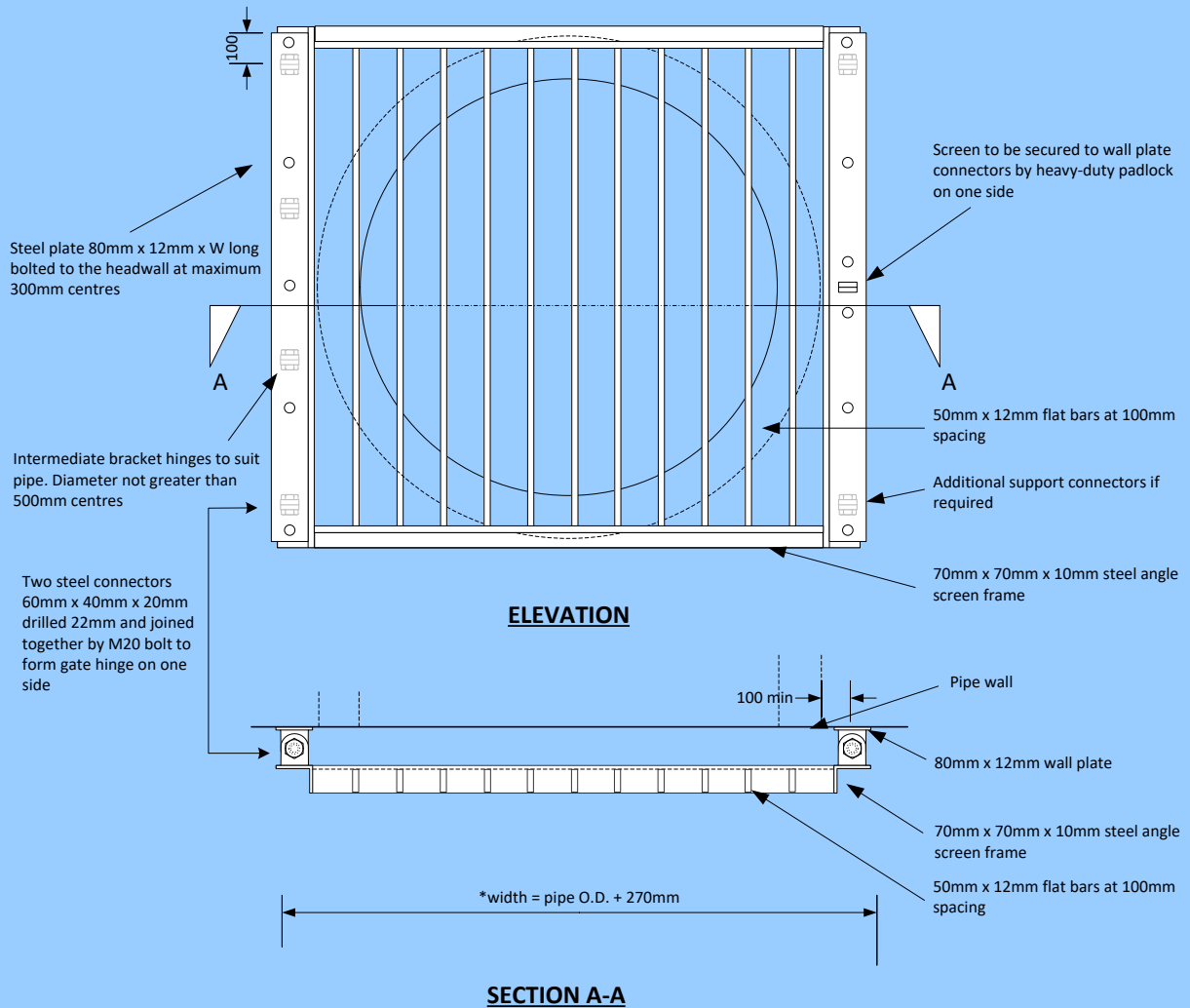
**FIGURE 5/5 - TYPICAL MANHOLE DETAIL - TYPE E**  
**Depth from cover level to soffit of pipe 1.0m to 1.5m**  
**Maximum sewer diameter 375mm**



**FIGURE 5/6a - ACCESS TO INVERT FOR PIPE DIAMETER EXCEEDING 600mm**



**FIGURE 5/6b - TYPICAL OUTFALL SAFETY GRILLE**  
**For Outfalls of 350mm Diameter Or Greater and No Flap Valve**



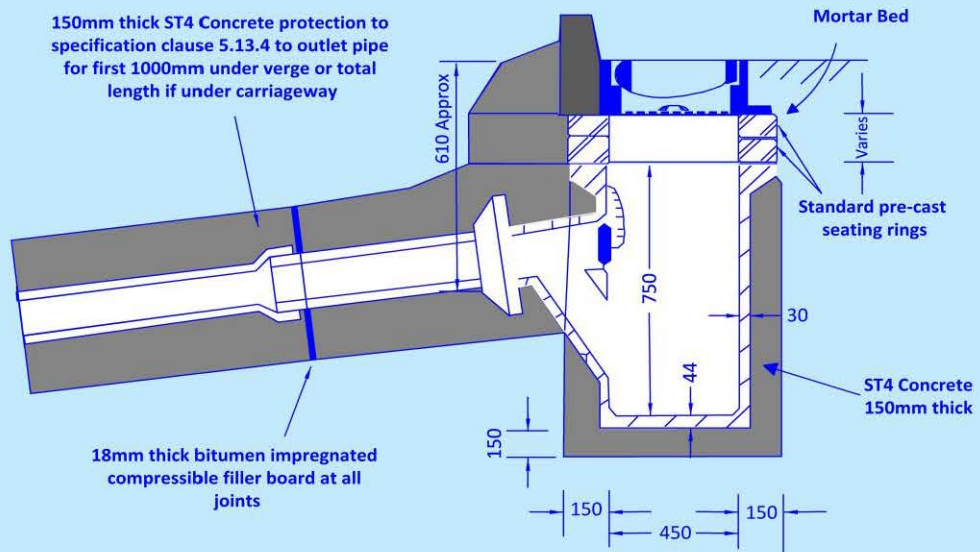
**DETAIL OF CONNECTOR**

- NOTES :-
- 1 \*width (W) to suit pipe outside diameter
  - 2 Mild steel fabrication to be hot dip galvanized to BS EN 1461
  - 3 Where flap valve is present advice should be sought from the Highway and Flood Authority

## **5.5 GULLIES AND CONNECTIONS**

- 5.5.1 All gullies shall be trapped.
- 5.5.2 Gully laterals shall be protected in accordance with Clause 5.13.4.
- 5.5.3 Gullies shall be precast concrete (see figure 5/7 – Typical Gully Details).
- 5.5.4 Precast concrete gullies shall be unreinforced and comply with the requirements of BS5911-4+A2::2010 and BSEN1917:2002..
- 5.5.5 Salt glazed ware gullies shall comply with the requirements for round gullies as specified in BS65.
- 5.5.6 Gully pots shall be at least 750mm deep by 450mm diameter with 150mm outlet, trapped and with stoppered rodding eye and chain.
- 5.5.7 Footway gullies shall be rectangular self-glazed ware or precast concrete to the approval of the Highway and Flood Authority. The gullies shall be 250mm square and 475mm deep, internal dimensions, and have a 150mm diameter outlet unless otherwise agreed with the Highway and Flood Authority.
- 5.5.8 Gullies shall be laid on and surrounded with 150mm thickness of ST4 concrete to clause 12.1 made with sulphate resisting cement unless agreed otherwise.
- 5.5.9 Junction pipes for gullies which are laid but not immediately connected to gullies shall be fitted with temporary plastic stoppers or seals and the position of all such junctions shall be clearly defined by means of stakes or tracing wires, properly marked and labelled.

## FIGURE 5/7 - TYPICAL GULLY DETAILS



### TYPE G5 TRAPPED ROAD GULLY

NOT TO SCALE

#### NOTES:-

- 1) Cover and frame uncoated iron to Clause 5.11.1.
- 2) Mortar bed and benching to Clause 5.11.8.
- 3) Standard pre-cast seating rings to comply to BS 5911-4:2010
- 4) All in situ concrete to be ST4 with sulphate resisting cement unless agreed otherwise.
- 5) Position of outlet pipe varies in plan.
- 6) In situ ST4 concrete 150mm thick surround to outlet pipe for first one metre under verge or total length if under carriageway.
- 7) Where grating is to be trafficked or laid against within 24 hours of frame being placed in position, then a suitable Ultra rapid hardening mortar and concrete (Monoset 241 or similar) shall be used to bed cover and frame.

## **5.6 Not Used**

## **5.7 GEOTEXTILES AND MEMBRANES**

- 5.7.1 Impermeable membranes are not permitted unless prior agreement has been sought from the Highway and Flood Authority
- 5.7.2 All membranes, textiles and liners should be designed, manufactured and installed in accordance with the relevant Standards, Codes of Practice and Manufactures Guidance. They should be selected in accordance with specific site conditions and be fit for purpose. All proposals need written technical approval from the Highway and Flood Authority prior to installation and use.
- 5.7.3 Geotextiles used in infiltration features shall be selected on the soil particle size confirmed in the ground investigation. This permeability of the geotextile shall be compatible with the infiltration rate used for the design.
- 5.7.4 All woven geotextiles shall have a minimum tensile strength of 30kN/m in each direction. Non-woven geotextiles shall have a minimum tensile strength of 15kN/m when tested in accordance with BS EN ISI 10319: 1996.
- 5.7.5 For woven geotextiles the pore size shall be 90% finer than 200/um. Non-woven geotextiles shall have a pore size 90% finer than 100/um
- 5.7.6 All Geotextiles shall have a minimum CBR puncture resistance of 3 kN.

## **5.8 BRICKWORK AND BLOCKWORK**

- 5.8.1 Concrete bricks or blocks to be used in manholes and chambers shall be precast concrete masonry units manufactured in accordance with BS 6073 containing a minimum of 360 kg/m<sup>3</sup> of sulphate resisting cement, having a maximum water/cement ratio of 0.45, a minimum compressive strength of 50 N/mm<sup>2</sup>, and a maximum water absorption of 7%.
- 5.8.2 Clay bricks to be used in manholes and chambers shall be Class B Engineering complying with the relevant provisions of BS EN 771-1 and particularly Table NA.6.
- 5.8.3 The shapes and dimensions of special bricks shall comply with the relevant provisions of BS 4729. All bricks shall be category F.
- 5.8.4 Brickwork and blockwork construction shall be in accordance with the relevant provisions of BS 5628-3.
- 5.8.5 Brickwork and blockwork shall be built in English bond. Bricks and blocks shall be set in mortar with all bed and vertical joints filled solid; exposed work shall be flush pointed as the work proceeds. The moisture content of the bricks and blocks shall be adjusted so that excessive suction is not exerted on the mortar.
- 5.8.6 Bricks and blocks in each course shall break joint correctly with the bricks/blocks underneath. The courses shall be laid parallel, with joints of uniform thickness, and shall be kept straight or regularly curved as required. Brickwork and blockwork shall be gauged to rise 300mm in four courses. Vertical joints shall be in alignment as required by the bond and shall have an average thickness of 10mm. Bricks and blocks forming reveals and internal and external angles shall be selected for squareness and built plumb.
- 5.8.7 Brickwork and blockwork shall rise uniformly; corners and other advanced work shall be racked

back and not raised above the general level more than 1m. No brickwork or blockwork shall be carried up higher than 1.5m in one day. No bats or broken bricks or blocks shall be incorporated in the work unless essential for bond.

5.8.8 Oversail corbelling shall not exceed 30mm on each course.

5.8.9 Materials used in bricklaying and block-laying shall be frost-free, and no bricks or blocks shall be laid when the ambient temperature is below 3°C, unless special precautions are taken. Completed work shall be protected adequately during cold weather.

## 5.9 **COVERS AND FRAMES**

5.9.1 Manhole and gully covers and frames shall be cast iron or ductile iron and comply with the relevant provisions of BS EN 124 and DMRB CD534. They shall be independently tested by a UKAS accredited organisation.

5.9.2 Manhole covers and frames shall be of a non-rocking design which does not rely on the use of cushion inserts. Covers and frames shall be ergonomically designed to ensure individual lift loads comply with manual handling legislation and the Management of Health and Safety at Work Act. Covers shall be hinged to the frame and when open they shall rest at an angle greater than 100° and locked in position to prevent accidental closing. The sections of cover must be capable of being removed from the frame to facilitate better access. In specific situations the Highway and Flood Authority may request manhole covers and frames that can be safely lifted by one operative for the purposes of routine visual inspection of ancillary equipment in highway drainage systems.

5.9.3 All manhole covers, gully grates and frames shall be 150mm deep.

**Table 5/4 Minimum manhole frame depths**

<b>Carriageway Description</b>	<b>Minimum frame depth</b>
A roads and dual carriageways	150
Bus services routes (including future routes)	150
All other roads except residential cul-de-sacs	150
Residential cul-de-sacs	150

5.9.4 Class D 400 covers and frames shall be used in carriageway and shared surface areas and shall have a minimum polished skid resistance value (PSRV) of 50. In areas of high stress the Highway and Flood Authority may increase the loading classification of covers and frames and increase the minimum PSRV for covers.

5.9.5 The minimum clear opening of manhole covers shall be in accordance with Table 5/5

**Table 5/5 Minimum Manhole Cover Sizes**

Depth to soffit om cover level (m)	Diameter of largest pipe in manhole <sup>a</sup> (mm)	Minimum clear opening size <sup>b,c</sup> (mm)
< 1.5	150	900 x 600
	225 to 900	1220 x 685
	> 900	Seek advice
≥ 1.5	150 to 900	600 x 600
	>900	Seek advice
> 3.0	Seek advice	Seek advice

Notes:

- a) Assuming single pipe entry. Multiple pipe entries may require larger and/or multiple covers.
- b) Manhole with ladders may need larger opening.
- c) Where ancillary devices are situated in manholes, larger clear openings than stated or multiple covers may be required.

- 5.9.6 Gully covers shall be hinged, but not removable, and shall have a nominal clear opening width of 450mm and a minimum area of waterway of at least 900cm<sup>2</sup> for carriageways, and a clear opening of at least 300mm x 300mm for footways. The upper surface of gully gratings shall be flat and slots in gratings or between gratings and frames shall not be orientated parallel to the direction of traffic except where the slots are less than 150mm long or less than 20mm wide. Where gradients are steeper than 1 in 50, storm pattern grids shall be provided.
- 5.9.7 Manhole and gully frames shall be set to level, bedded and haunched externally over the base and sides of the frame on an approved bedding material and in accordance with the manufacturer's instructions. The frame shall be entirely seated on precast concrete cover frame seating rings to regulate the distance between the top of the cover and the top rung to no greater than 675mm. A mortar fillet shall be provided where the corners to an opening in a slab are chamfered and the brickwork is not flush with the edges of the opening.
- 5.9.8 Frames shall be bedded on a non-shrink proprietary material which shall have a workable life of 15 minutes. The compressive strength of the bedding material shall exceed 30N/mm<sup>2</sup> and its tensile strength should exceed 5N/mm<sup>2</sup>. A 1:2 mix should achieve this. The bedding material must be appropriate for the site and weather conditions at time of mixing. The depth of bedding material shall not exceed the manufacturer's recommendations. The bedding material shall be mixed and laid in accordance with the manufacturer's instructions. Packing materials are not permitted unless approved by the bedding material manufacturer and the Highway and Flood Authority.
- 5.9.9 Only materials complying with Clause 9 generally and in particular Clauses 9.1, 9.2, 9.3, 9.4 (footway only) and 9.5 shall be used to re-instate the surfacing around gullies and frames following their installation or adjustment. The materials shall be placed in layers such that the compacted thickness of the individual layer shall not be less than 2.5 times and not greater than 5 times the nominal size of the material. When material to Clause 9.6 is used as the surface course layer coated chippings to Clause 9.6 shall be incorporated within such surface course.



## **5.10 EXCAVATION FOR DRAINAGE WORKS INCLUDING CHANNELS, SWALES AND PONDS**

- 5.10.1 The Developer shall carry out his operations in such a manner as to avoid damage to, or deterioration of, the formation of excavations.
- 5.10.2 Soft spots shall be removed from the bottom of trenches and other excavations, which shall then be refilled to formation level with the same material as the permanent work which is to rest on that formation. Any void which results from over-excavation below formation level shall be refilled in the same manner.
- 5.10.3 Trenches shall be excavated so that the effective width is maintained within any limit imposed by the design of the pipelines.
- 5.10.4 Trenches, manholes and all excavations shall be adequately supported at all times and, where directed or required, the supports shall be left in trenches or excavations.
- 5.10.5 The Developer shall not allow water to accumulate in any part of the works. Water arising from or draining into the works shall be drained or pumped to a consented disposal point. Any drainage sumps required shall, where practicable, be sited outside the area excavated for the permanent works, and shall be refilled with Type 1 sub-base material or ST1 concrete to the level of the underside of the adjacent permanent works.
- 5.10.6 The Developer shall take all necessary precautions to prevent any adjacent ground from being adversely affected by loss of fines through any dewatering process.

## **5.11 BACKFILLING OF TRENCHES FILTER DRAINS AND SWALES**

- 5.11.1 Subject to the requirements of Clause 5.14.1, backfilling shall, wherever practicable, be undertaken immediately the specified operations preceding it have been completed. Backfilling shall not, however, be commenced until the works to be covered have achieved a strength sufficient to withstand all loading imposed thereon.
- 5.11.2 Backfilling around manholes and gullies shall be undertaken in such a manner as to avoid uneven loading or damage.
- 5.11.3 Excavations not situated beneath the carriageway or footway shall be refilled with approved and/or suitable excavation material as defined and classified by the Specification for Highway Works. All filling shall be deposited and compacted in layers, not exceeding 150mm loose depth, to a density not less than 95% of the maximum dry density for that particular filling, as determined by the light hammer test BS1377: Part 4: Tests 3.3 and 3.4. Trench support systems shall be withdrawn ahead of the layer to be compacted, care being taken to keep the sides of the trenches solid and to fill all the spaces left by the withdrawn trench support systems. When suitable material cannot be sourced and the width of excavation is greater than 850mm, and at an appropriate depth, approved 6F5 Capping material can be used to Clause 6.8. The Highway and Flood Authority may require the use of sub-base to Clause 8.1 in place of excavated material where trenches are deep or narrow.
- 5.11.4 All trenches and other excavations beneath or within 1m of carriageways and footways, including drains in carriageways, footways and vehicle crossings, must be refilled with sub-base as specified in Clause 8.1. It is accepted that due to trench widths, the requirements to use rollers to compact the sub-base in trenches may be inappropriate. In these circumstances, alternative compaction equipment may be used to ensure that the compaction requirements are met.

- 5.11.5 Filter drains including those forming the base of swales shall be backfilled with Type B filter material which shall consist of natural or recycled coarse aggregate or recycled concrete aggregate complying with BS EN 13242 and the following:
- (i) for Type B, geometrical requirements in accordance with Table 5/6 and BS EN 13242;
  - (ii) a resistance to fragmentation in Category LA50 in accordance with BS EN 13242, clause 5.2 and Table 9;
  - (iii) a water-soluble sulfate content of less than 1.9 grams of sulfate (as SO<sub>3</sub>) per litre when tested in accordance with BS EN 1711-1, clause 10;
  - (iv) volume stability of slags as in Table 5/6;
  - (v) all other requirements in Category NR;
  - (vi) be non-plastic when tested in accordance with BS 1377:Part 2.
- 5.11.6 Recycled aggregate used as filter material shall be produced in accordance with the WRAP (The Waste and Resources Action Programme) Quality Protocol produced in conjunction with the Environment Agency: *Aggregate from inert waste*.
- 5.11.7 The result of all quality control checks carried out by the producer shall be compiled in accordance with the procedure set down in the above document. These shall be made available promptly to the Highway and Flood Authority on request.
- 5.11.8 When recycled aggregate including recycled concrete aggregate is used in accordance with this Clause, it shall not have more than 1% by mass of foreign materials including wood, plastic and metal nor a floating material in volume content exceeding 10cm<sup>3</sup>/kg when tested in accordance with BS EN 933-11. The test shall be carried out by a suitably trained laboratory technician who has demonstrated competence in classifying the constituent classes in accord with the test method.
- 5.11.9 The aggregate shall not have threshold levels exceeding those in the *ADEPT Guidance Note - Managing Reclaimed Asphalt - Highways and Pavements*

**Table 5/6 Grading and geometrical requirements for filter drain and soakaway material**

	<b>Type B</b>
Standard	BS EN 13242
Size, mm	20/40
Grading and oversize categories	G <sub>C</sub> 80-20
Oversize category	-
Category for tolerances at mid-size sieves	GT <sub>NR</sub> (no requirement)
Category for maximum fines	f <sub>NR</sub> (no requirement)
Volume stability of blast furnace slags	Free from dicalcium silicate and iron disintegration
Volume stability of steel (BOF and EAF) slags	V <sub>5</sub>
Summary grading requirements	
Sieve size, mm	Percentage by mass passing
80	100
63	98-100
40	80-99
20	0-20
10	0-5

## **5.12 PIPELAYING**

- 5.12.1 Where socketed pipes are required to be laid on a granular or sand bed, or directly on a trench bottom, joint holes shall be formed in the bedding material or formation to ensure that each pipe is uniformly supported throughout the length of its barrel and to enable the joint to be made.
- 5.12.2 Pipes shall be laid on setting blocks only where a concrete bed or cradle is used.
- 5.12.3 Where pipes are required to be bedded directly on the trench bottom, the formation shall be trimmed and levelled to provide even bedding of the pipeline and shall be free from all extraneous matter that may damage the pipe, pipe coating or sleeving.
- 5.12.4 Pipes and fittings shall be examined for damage and the joint surfaces and components shall be cleaned immediately before laying.
- 5.12.5 Suitable measures shall be taken to prevent soil or other material from entering pipes, and to anchor each pipe to prevent flotation or other movement before the works are complete.
- 5.12.6 Pipes shall be cut in accordance with the manufacturer's recommendations. Where necessary, the cut ends of pipes shall be formed to the tapers and chamfers suitable for the type of joint to be used.
- 5.12.7 Pipe jointing surfaces and components shall be kept clean and free from extraneous matter until the joints have been made or assembled. Care should be taken to ensure that there is no ingress of grout or other extraneous material into the joint annulus after the joint has been made.

- 5.12.8 Where concrete pipes are cut, any exposed reinforcement shall be sealed with an epoxy resin mortar.
- 5.12.9 The position of the internal face of any highway drain shall not deviate from the line and level described in the Agreement or agreed variation by more than  $\pm 20\text{mm}$ , provided that no pipeline shall have a reverse gradient.

### **5.13 BEDDING, LAYING AND SURROUNDING OF PIPES**

- 5.13.1 Immediately following the excavation of the trench, the pipes shall be laid and jointed on the pipe bed. Pipes shall be laid so that each one is in contact with the bed throughout the length of its barrel. Brick, concrete setting blocks or other hard material shall not be placed under the pipes for temporary support. In the case of socketed or sleeved jointed pipes, the bed shall be cut away and removed at each socket or sleeve so that the socket or sleeve does not bear on the bed.
- 5.13.2 Pipe bedding and haunching or surrounding material shall consist of natural and/or recycled aggregate including recycled concrete aggregate complying with BS EN 13242. Recycled aggregates used as pipe bedding and haunching or surrounding material shall be produced in accordance with the WRAP (The Waste and Resources Action Programme) Quality Protocol produced in conjunction with the Environment Agency: *Aggregate from inert waste*. The results of all quality control checks carried out by the producer shall be compiled in accordance with the procedure set down in the above document. These shall be made available promptly to the Highway and Flood Authority on request. Where recycled coarse aggregate or recycled concrete aggregate is used in this Clause it shall not have more than 1% by mass of foreign materials including wood, plastic and metal nor a floating material in volume content exceeding  $10\text{cm}^3/\text{kg}$  when tested in accordance with BS EN 933-11 by a suitably trained laboratory technician who has demonstrated competence in classifying the constituent classes in accordance with the test method (see Clause 1.1.14) and comply with the requirements in Table 5/7 and 5/8. The aggregate shall not have threshold levels exceeding those in the *ADEPT Guidance Note – Managing Reclaimed Asphalt – Highways and Pavements*. Pipe bedding, haunching and surrounding material shall comply with the following:

Geometrical requirements in accordance with Table 5/7 or Table 5/8;

A resistance to fragmentation in Category LA50 in accordance with BS EN 13242, clause 5.2 and Table 9;

A water soluble sulfate content of less than 0.19% (as  $\text{SO}_3$ ) when tested in accordance with BS EN 1744-1, clause 10; (d) Blast furnace slags shall be free from dicalcium silicate and iron disintegration;

The volume stability of steel (BOF and EAF) slags shall be  $V_5$ ;

All other requirements shall be Category NR.

**Table 5/7: BS EN 13242, Coarse aggregate for pipe bedding, haunching and surrounding material**

<b>BS EN 13242, Coarse aggregate (clause 4.3.2)</b>		
<b>Category for general grading requirements</b>	<b>G<sub>C</sub>80-20</b>	
<b>Category for tolerances at mid-size sieves</b>	<b>GT<sub>NR</sub> (no requirement)</b>	
<b>Category for maximum values of fines content</b>	<b>Gravel – f<sub>1.5</sub> Crushed rock, recycled aggregate – f<sub>4</sub></b>	
<b>Nominal pipe diameter, mm</b>	<b>Aggregate size, mm</b>	
	<b>Graded</b>	<b>Single sized</b>
<b>Not exceeding 140</b>	-	<b>4/10</b>
<b>Exceeding 140 but not exceeding 400</b>	<b>2/14, or 4/20</b>	<b>4/10, 6/14 or 10/20</b>
<b>Exceeding 400</b>	<b>2/14, 4/20 or 4/40</b>	<b>4/10, 6/14, 10/20 or 20/40</b>

**Table 5/8: BS EN 13242, Fine and all-in aggregate for pipe bedding, haunching and surrounding material**

<b>BS EN 13242, Fine and all-in aggregate (clause 4.3.3)</b>		
	<b>Fine</b>	<b>All-in</b>
<b>Category for general grading requirements</b>	<b>Category G<sub>F</sub>80</b>	<b>Category G<sub>A</sub>80</b>
<b>Category for tolerances on manufacturer's Declared typical grading</b>	<b>GT<sub>FNR</sub> (no requirement)</b>	<b>GT<sub>ANR</sub> (no requirement)</b>
<b>Category for maximum values of fines content</b>	<b>Gravel – f<sub>3</sub> Crushed rock, recycled aggregate – f<sub>11</sub></b>	
<b>Nominal pipe diameter, mm</b>	<b>Aggregate size, mm</b>	
	<b>Fine</b>	<b>All-in</b>
<b>Not exceeding 140</b>	<b>0/1, 0/2, 0/4 or 0/6</b>	<b>0/10</b>
<b>Exceeding 140 but not exceeding 400</b>		<b>0/10 or 0/20</b>
<b>Exceeding 400</b>		<b>0/10, 0/20 or 0/40</b>

- 5.13.3 Following placement of the pipe and surrounding material the pipe shall be marked by a detectable warning mesh located immediately on top of the pipe surrounding material. The detectable warning mesh should be colour coded as recommended in Volume 1 NJUG Guidelines on the Positioning and Colour Coding of Underground Utilities.
- 5.13.4 150mm diameter pipes (typically gully laterals) to be surrounded with concrete shall be supported on precast concrete setting blocks, the top face of each block being covered with two layers of compressible packing.
- 5.13.5 Precast concrete setting blocks for pipes shall have rectangular faces, with sufficient plan area to prevent punching of the blinding concrete or formation and to provide an adequate seating for the pipes. Blocks shall be manufactured from ST4 concrete using the same type of cement as in the adjacent concrete bed, and be cast in an approved mould. Blocks shall not be used

until they have achieved a cube strength of 13.5 N/mm<sup>2</sup>.

- 5.13.6 Concrete provided as a protection to pipes shall be ST4 placed to the required depth of 150mm above and below the pipe for the full width of the trench in one operation. Where pipes with flexible joints are used, concrete protection shall be interrupted over its full cross-section at each pipe joint by a shaped compressible filler.
- 5.13.7 Compressible filler for interrupting concrete protection to pipes shall consist of bitumen impregnated insulating board to BS EN 120 and BS EN 317, or other equally compressible material. The thickness of compressible filter shall be as given in Table 5/9 below:

**Table 5/9**

<b>Nominal diameter of pipe (mm)</b>	<b>Thickness of compressible filler (mm)</b>
Less than 450	18
450 – 1200	36
Exceeding 1200	54

- 5.13.8 Compressible packing for use between pipes and precast concrete setting blocks shall consist of bitumen damp-proof sheeting complying with BS 743.

For pipes 150mm or greater in diameter (main runs) ductile iron in accordance with Clauses 5.5.7/8/9/10 shall be used. Alternatively, a reinforced concrete slab that does not allow any loading to bear on the highway drain shall be constructed. The design shall be specific to the location and take into account construction as well as road vehicle loadings, the bearing capacity of the ground and the trench width.

#### **5.14 INSPECTION TESTING AND CLEANSING**

- 5.14.1 The Developer shall afford opportunity for the Highway and Flood Authority to examine any work which is about to be covered up or put out of view, and to examine foundations before permanent work is to be placed thereon.
- 5.14.2 The Developer shall give at least five clear working days' notice to the Highway and Flood Authority before any formation is covered with permanent work and before testing any pipeline. The Highway and Flood Authority will witness all tests to pipelines.
- 5.14.3 Pipelines shall be tested by the Developer after they are jointed and before any concreting or backfilling is commenced, other than such as may be necessary for structural stability whilst under test.
- 5.14.4 A further test shall be carried out after the backfilling is complete.
- 5.14.5 Pipelines up to and including 750mm nominal diameter shall be tested by means of an air or water test; and sewers greater than 750mm nominal diameter by a visual examination. Visual examination may include a CCTV survey and/or walk-through inspection in accordance with clauses 5.14.16 and 5.14.17 respectively and provide the Highway and Flood Authority with the results for consideration. Pre-cleansing of the pipeline in accordance with clause 5.14.14 may be necessary. CCTV surveys will be required for all perforated pipe lines.

- 5.14.6 Pipelines to be air tested shall have air pumped in by a suitable means until a pressure of 100mm head of water is indicated in a U-tube connected to the system. The pipeline shall be accepted if the air pressure remains above 75mm head of water after a period of five minutes without further pumping, following a period for stabilisation. Failure to pass the test shall not preclude acceptance of the pipeline if a successful water test can subsequently be carried out, as follows.
- 5.14.7 The test pressure shall not be less than 1.2m head of water above the pipe soffit or ground water level, whichever is the higher, at the highest point, and not greater than 6m head at the lowest point of the section. Steeply graded pipes shall be tested in stages in cases where the maximum head, as stated above, would be exceeded if the whole section were tested in one length.
- 5.14.8 The pipeline shall be filled with water and a minimum period of two hours shall be allowed for absorption, after which, water shall be added from a measuring vessel at intervals of five minutes and the quantity required to maintain the original water level noted. Unless otherwise specified, the length of sewer shall be accepted if the quantity of water added over a 30 minute period is less than 0.5 l per linear metre per metre of nominal diameter.
- 5.14.9 Notwithstanding the satisfactory completion of the above test, if there is any discernible leakage of water from any pipe or joint, the pipe shall be replaced and/or the joint remade, as appropriate, and the test repeated until leakage is stopped.
- 5.14.10 Should there be any concerns over the integrity of a pipeline at any stage of the Development, the Highway and Flood Authority may request the Developer to carry out a visual inspection in accordance with clauses 5.14.16 and 5.14.17 and provide the Highway and Flood Authority with the results for consideration. Pre-cleansing of the pipeline in accordance with clause 5.14.14 may be necessary.
- 5.14.11 Pipelines and manholes shall be inspected and tested for infiltration, after backfilling. All inlets to the system shall be effectively closed, and any residual flow shall be deemed to be infiltration.
- 5.14.12 The pipeline and manholes shall be accepted as satisfactory if the infiltration, including infiltration into manholes, in 30 minutes does not exceed 0.5 l per linear metre per metre of nominal bore.
- 5.14.13 Notwithstanding the satisfactory completion of the above inspection or test, if there is any discernible flow of water entering the sewers of manholes which can be seen either by visual or CCTV inspection, the Developer shall take such measures as are necessary to stop such infiltration.
- 5.14.14 On completion of construction, internal surfaces of pipelines, gullies, linear drainage systems and manholes shall be thoroughly cleansed to remove all deleterious matter, without such matter being passed forward into existing public sewers, highway drains, or water courses. The pipelines, gullies and manholes shall be maintained in a clean and serviceable condition by the Developer until they are adopted by the Highway and Flood Authority. Jetting pump pressures shall not exceed the pressures shown in Table 5/10 and jetting flow rates shall exceed the figures in Table 5/11

**Table 5/10 Maximum jetting pump pressures**

<b>Material</b>	<b>Maximum pump pressure (bar/psi)</b>
Clay	340/5000
Concrete	340/5000
Ductile iron	Seek Advice
Plastic – Structural Wall	127/1900
Plastic – Solid Wall	127/1900

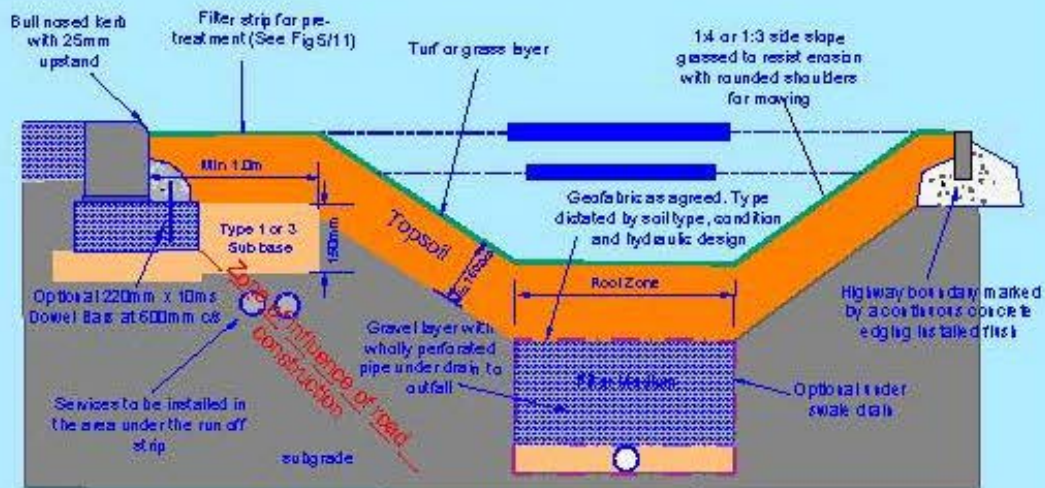
**Table 5/11 Minimum Jetting Flow Rates**

<b>Pipe Diameter (mm)</b>	<b>Minimum jetting flows (l/min)</b>
<230	156
231 – 450	270
451 - 900	300
901 - 1600	342

- 5.14.15 Immediately prior to the commencement of the maintenance period the developer shall clean the highway drainage system and ancillary equipment to the satisfaction of the Highway and Flood Authority with respect to Clause 5.14.14.
- 5.14.16 Following cleansing of the highway drainage system, the developer shall undertake a CCTV survey of all pipes and culverts (including gully laterals) comprising the highway drainage system. The CCTV survey shall be reported in accordance with BS EN 13508 Part 1:2012 and BS EN 13508 Part 2:2003 + A1:2011. The CCTV surveyor shall hold a WTI Pipe Sewer Condition and Classification certificate or similar approved. Where a brick sewer has been connected into the CCTV operator shall also hold a WTI Brick Sewer Condition and Classification certificate or similar approved.
- 5.14.17 The CCTV survey shall be presented in DVD format together with a written report and dispatched to the Technical Manager Development or nominated representative for review or approval. Any defects found will be made good by the Developer prior to adoption.
- 5.14.18 Where the diameter of the pipeline exceeds the manufacturers operating limits of available sewer CCTV equipment the Developer shall organise a walk through inspection of the pipeline by specialist contractors. The appointed specialist contractor shall be competent, experienced and trained in undertaking such surveys in confined spaces and the surveyor recording the defects shall hold a WTI Pipe Sewer Condition and Classification certificate or similar approved and record and present the survey in accordance with BS EN 13508 Part 1:2012 and BS EN 13508 Part 2:2003 + A1:2011. Where the pipeline inspection includes brick pipelines the surveyor shall also hold a WTI Brick Sewer Condition and Classification certificate or similar or approved.
- 5.14.19 The survey photographs will be recorded onto DVD and presented with a written report to the Highway and Flood Authority for review / approval. Any defects found will be made good by the Developer prior to adoption.



**FIGURE 5/8 – SWALES AND SURFACE WATER FLOW CONVEYANCE**

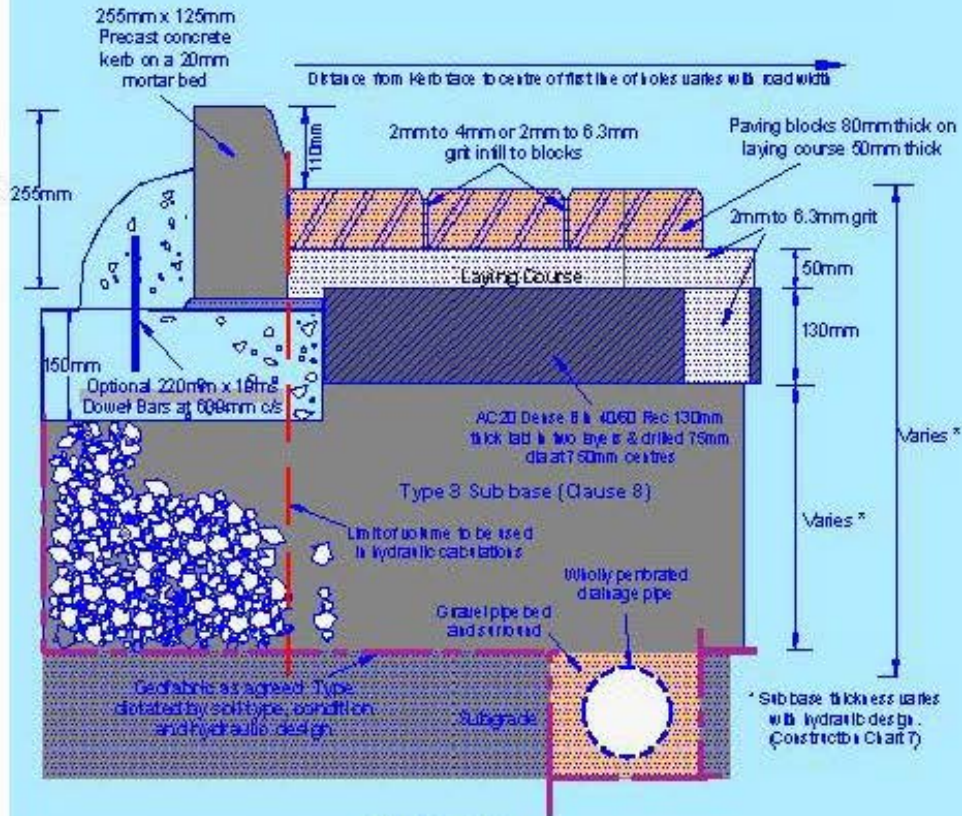


Note:-The swale must be of sufficient depth to prevent car/water run off over spilling beyond the highway boundary

## Design Data

Element	Summary Requirement
1 Depth of swale	200mm to 600mm
2 Base width of swale	0.5m to 2.0m
3 Side slopes of swale	Recommended 25% to a maximum of 33%
4 Longitudinal bed of swale	0.5% to 6%
5 Minimum longitudinal length of swale	5.0m
6 Drop from adjacent surface into swale (lateral surface flows)	50mm to 100mm
7 Permeable geotextile filter membrane	Clause 5.9
8 Under drainage pipe and flow capacity	Perforated PVC min dia 150mm and min 2l/s/ha
9 Gravel layer surrounding perforated pipe	Min 150mm thick clean gravel to C5.15 and table 5/7
10 Filter medium under dry swale	Type B open graded granular material to C5.13
11 Positioning of "check dams"	10m to 20m internals on slopes greater than 3%. Details to be agreed
12 Maximum groundwater level	At least 1m below bed
13 Grass seed mixture	Standard amenity mix with wildflower component
14 Under drains on conveyance swales	On slopes <1.5%
15 Vegetation height within swale	75mm to 150mm
16 Average depth and velocity of flow	100mm and 0.3m/s
17 Excess flow velocity	Limited to be between 1m and 3m/s
18 Topsoil thickness over subsoil	150mm
19 Distance from carriageway	Minimum 1.0m
20 Distance from structures	Seek further advice from Building Control
21 Root Zone	70/30 mix of sand/loam as C16.2

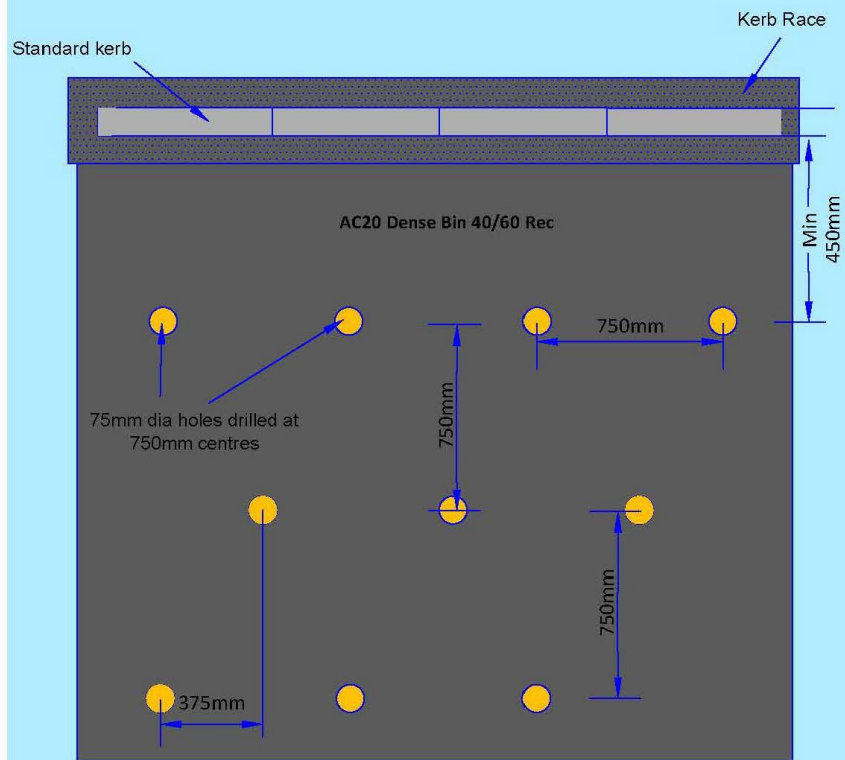
**FIGURE 5/9 – TYPICAL ROAD SECTION PERVIOUS PAVEMENTS**  
**SuDS Manual Type A & Type B**



**Design Data**

	Element	Summary Requirement
1	Minimum permeable CBR value	Absolute minimum 3% soaked CBR
2	Depth of Sub base	Chart 7 and BS7533
3	Laying Course (for block paving)	To Clause 10.4
4	Longitudinal slopes on surface	<0.05%
5	Surface layer permeability	>500mm/h
6	Permeable geotextile filter membrane	To Clause 5.9
7	Under drainage pipe and flow capacity	Perforated PVC min 150mm dia and min 2 l/s/hr
8	Sub base	To Clause 8
9	Maximum water depth for design event	Top of road base
10	Maximum ground water level	Max 1m below infiltration flow outlet
11	Slopes under drains	On slopes <1.5%
12	Minimum width of (a) type gravel/slab sloping away from pavement edge	400mm
13	Surface slope away from pavement edge	0.05%
14	Perforated drainage pipe level	To be dependent on traffic loading/strength & class of pipe etc.
15	Perforated drainage pipe	Must be shown to be capable of carrying the required traffic loading
16	AC20 Dense Binder Course layers	Layer 170mm thick layer 250mm thick

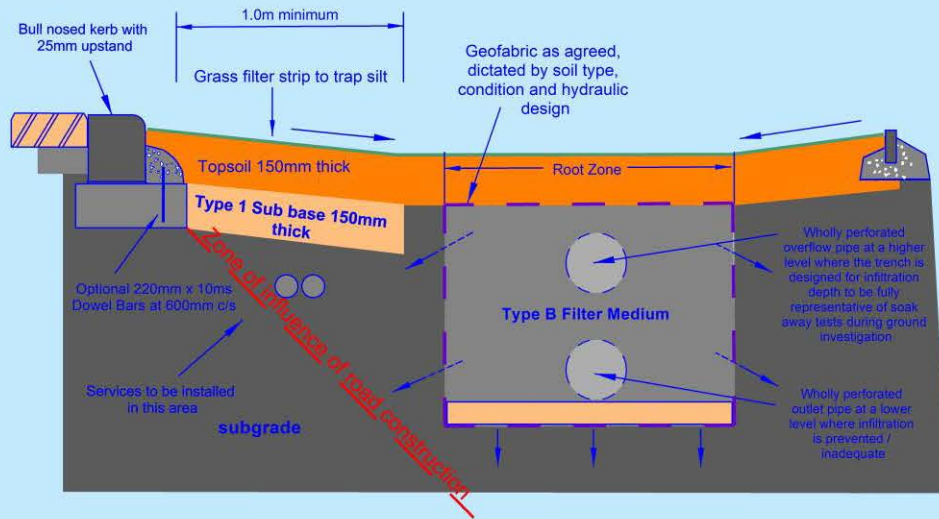
**FIGURE 5/10 – PERVIOUS PAVING  
Typical Plan for Carriageway Bindercourse Coring**



**Notes**

- ) Holes cored at 750mm centres in rows 750mm apart evenly spaced across the carriageway.
- ) Each row offset by 375mm as per drawing
- ) Cleanliness is essential. All water, slurry and debris to be mechanically removed from the holes to leave clean sub base (eg. a wet/dry vacuum appliance).

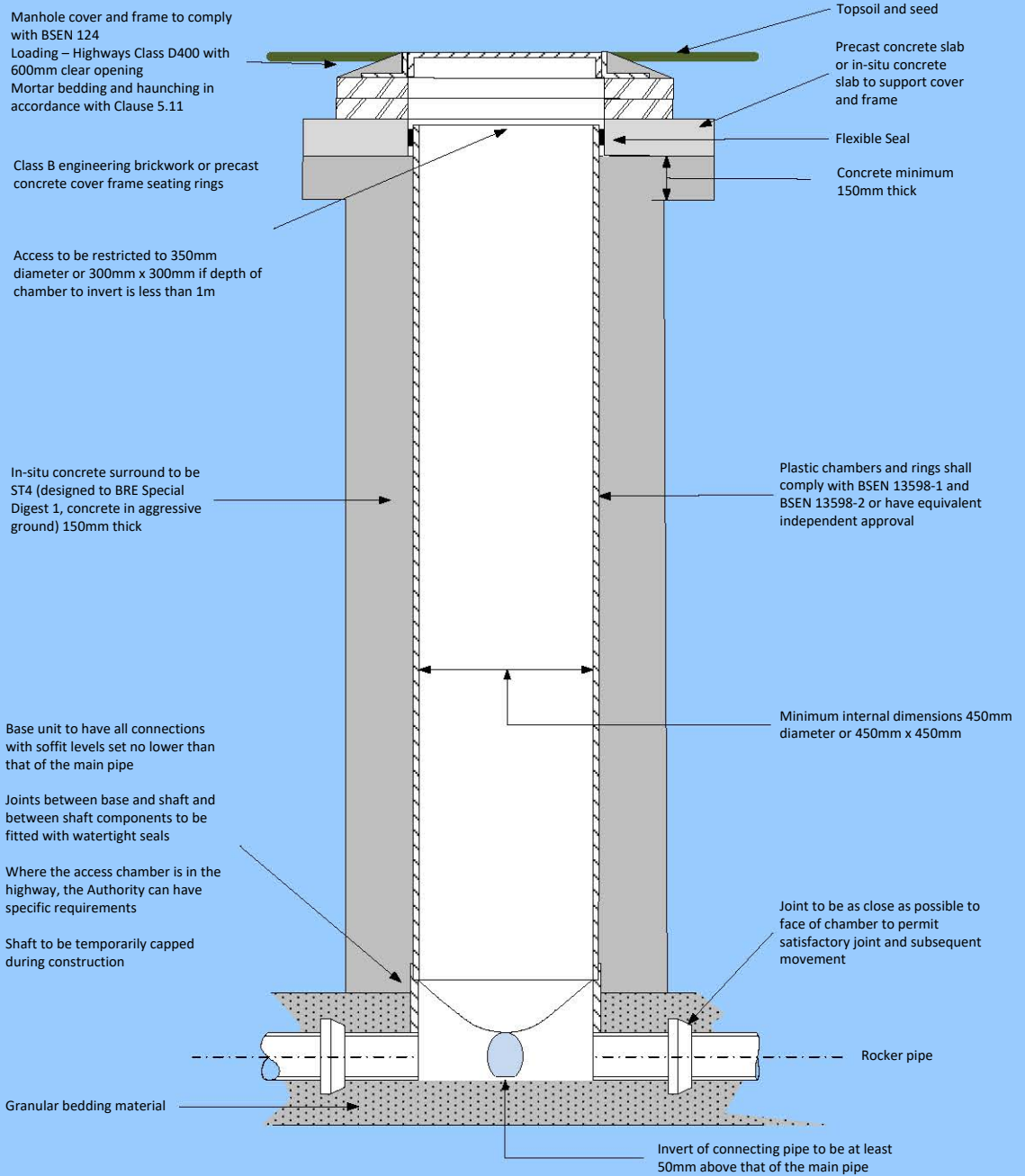
**FIGURE 5/11 – FILTER DRAINS AND INFILTRATION TRENCHES**



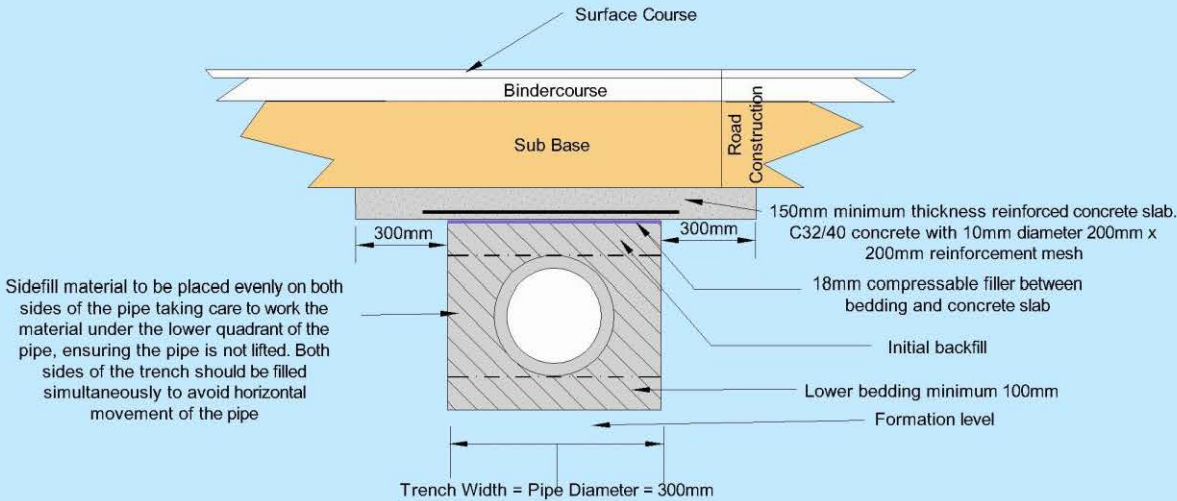
**Design Data**

	Element	Summary Requirement
1	Depth of Trench	1-2m & min 600mm below highway formation level
2	Width of Trench	Between 450mm and 900mm
3	Maximum longitudinal slopes	2%
4	Permeable geotextile filter membrane	Clause 5.9
5	Under-drainage pipe and flow capacity	Perforated (max 10mm dia) PVC Min 150mm dia and min 21s/ha
6	Gravel layer surrounding drainage pipe	Min 150mm thick clean gravel to Clause 5.15 and Table 5.7
7	Filter medium in trench	Type B Open Graded granular material with minimum porosity of 30% to Clause 5.13
8	Positioning of inspection chamber	10m to 90m intervals
9	Maximum ground water level	At least 1m below base of the trench
10	Grass seed mixture	Standard amenity mix with wildflower component
11	Minimum width between silt trap and pipe	0.5m
12	Minimum vegetation height on side silt traps	150mm
13	Topsoil thickness ove sub soil	150mm
14	Minimum depth of filter medium below pipework	0.5m
15	Sacrificial stone filter layer	Type B to Clause 5.13
16	Maximum surface water flow depth	100mm
17	Maximum flow velocity across filter strip surface	1.5m/s
18	Maximum depth of silt build up	75mm
19	Maximum distance from structural foundations	Seek further advice from Building Control
20	Minimum distance from carriageway	1.0m
21	Root Zone	70/30 mix of sand/topsoil as Cl 6.2

**FIGURE 5/12 - TYPICAL INSPECTION CHAMBER DETAIL**  
**Maximum depth from cover level to soffit of pipe 1.5m (non-entry)**  
**For Use in Features SuDS only**



**FIGURE 5/13 – TYPICAL CONCRETE SLAB PIPE PROTECTION  
(Only for pipes below 600mm diameter)**



Diameter of Pipe (mm)	Thickness of Compressible Filler (mm)*
<450	18
450 - 1200	36
>1200	54

\* Bitumen impregnated insulating board to BS120 and BSEN137

## 6. EARTHWORKS

---

### 6.1 FORMATION LEVEL

- 6.1.1 Formation level is the finished level of the existing soil after completion of the earthworks, i.e. the underside of the sub-base. Any excess depth excavated shall be backfilled with sub-base material in accordance with Clause 8.1.
- 6.1.2 Within 24 hours of the final preparation of the formation level it shall be covered with a minimum thickness of 150mm of compacted sub-base in accordance with Clause 8.1. Construction traffic shall not run on the prepared formation.

To prevent problems of weed growth, a suitable weed killer should be applied to the formation of the footway.

### 6.2 TOPSOIL

- 6.2.1 Turf and all topsoil shall be removed from the area of the roadworks and stockpiled for re-use. Topsoil shall mean the top layer of soil which can support vegetation. The depth of topsoil should be established in the ground investigation and will be the subject of confirmation during formation key stage checks. Imported topsoil shall be Class A multipurpose as defined by BS 3882:2015 Cl 4.1 and Table 1.
- 6.2.2 For SuDS, root zone mix shall comprise a 70/30 mix of sand/topsoil. The topsoil shall meet the requirements of British Standard BS 3882:2015 Specification for Topsoil. Sand shall meet the following requirements:

#### **Grading:**

Sieve Size (mm)	% Passing
5.00	89 to 100
2.36	65 to 100
0.30	5 to 50
0.063	<4

Saturated hydraulic conductivity >220mm/h  
Total porosity >30% v/v  
pH 6.5 to 8.5

### 6.3 SOILING, GRASSING AND TURFING

- 6.3.1 Soiling and compacting of the side slopes of cuttings, embankments and verges shall be carried out to an even surface with a minimum compacted thickness of 150mm of topsoil. (The use of the word 'compacting' is as a preparation for seeding or turfing and should be carried out by treading the area several times in different directions and then rake several times also in different directions. Vibrating compactors should never be used for this operation.)
- 6.3.2 All surfaces to be grassed shall, immediately before sowing, be reduced to a fine tilth and all stones over 20mm diameter and all harmful material shall be removed. Fertilizer from an approved manufacturer, in the following parts - 10 Nitrogen: 15 Potassium: 10 Phosphorous shall be spread in two directions at a total rate of 50gm/m<sup>2</sup>. Grass seed from an approved manufacturer, shall be spread in two directions at a total rate of not less than 1kg to 50m<sup>2</sup> and shall consist of the following parts:-

For Non SuDS applications:

25% Barkoel Crested Hairgrass  
20% Hardtop Hard Fescue  
35% Barpearl Slender Creeping Red Fescue  
20% Bargreen Chewings Fescue

#### 70% Wildflowers

Bird's Foot Trefoil, Common Knapweed, Common Sorrel, Creeping Bent, Creeping Buttercup, Crested Dogstail, Lady's Bedstraw, Meadow buttercup, Meadow Foxtail, Meadowsweet, Plantain, Ragged Robin, Salad burnet, Selfheal, Slender Creeping Red Fescue, Smoothstalked Meadowgrass, Sweet Vernal Grass, Wild Carrot, Wild Red Clover, Yarrow.

#### 30% Grasses

Creeping Bent, Meadow Foxtail, Sweet Vernal Grass, Crested Dogstail, Slender Creeping Red Fescue, Smoothstalked Meadowgrass.

- 6.3.3 SuDS application areas shall be seeded with a standard amenity grass mix with a wildflower component or a specific mix can be agreed with the Highways and Flood Authority on a site by site basis.
- 6.3.4 Turfing shall be carried out on topsoil using turfs to BS 3969:1998+A1:2013 Recommendations for turf for general purposes, to give a total minimum thickness of 100mm of topsoil. Turfs shall be clean, strong, well bonded and lightly beaten. They shall be laid diagonally across side slopes. All turves shall be used within 3 days of cutting during the period 1 April to 31 August or within one week of cutting during the remainder of the year; turves not used within these periods shall be regarded as topsoil.
- 6.3.5 Grassed areas shall be maintained up to and during the 12 month maintenance period in order to control weed growth and additionally grass length across the root zone shall be maintained at a length of 75mm to 150mm to ensure suitable performance of the SuD's feature.

## **6.4 EMBANKMENTS AND CUTTINGS**

- 6.4.1 Where the nature of the works are such that embankments or cuttings are necessary then the excavation, classification and placement of materials shall be in accordance with the requirements of the Highways England's current Specification for Highway Works. The site investigation shall address such matters as slope stability, settlement and, where necessary, heave. The ground investigation and associated testing will need to be undertaken, to determine if the materials are acceptable and if so, to classify them as either Class 1 or Class 2 general fill materials.
- 6.4.2 The proposal to use a particular Class 1 or Class 2 material shall include:-
- The proposed material source.
  - Proposed material classification against the requirements of Clause 601, Table 6/1. Where acceptable limits are not quoted in the Table, these will have to be determined for the particular source of material and its end use.
  - Proposed means of monitoring the material's suitability as it is delivered to site, included sampling and testing frequency.
  - Proposed method of compaction and type of plant to be used.
  - Proposed means of monitoring its placement and in particular its end product compaction.
  - Proposed method of assessing the design CBR at sub-formation level, that is on the



placed and compacted fill material, to permit adjustment to the final sub-base design thickness. This design CBR is likely to be different to that determined on the existing sub-grade.

Developers will require the professional services of an experienced Geotechnical Engineer to prepare their documentation. All laboratory testing must be undertaken by an UKAS accredited laboratory.

The cost of all the additional work associated with preparing and undertaking their proposal will be at their expense.

## 6.5 **DISPERSAL OF STANDING WATER**

The Developer must ensure the rapid dispersal of water shed onto or entering the site from any source at all times during construction, particularly water which is shed onto the completed sub-grade, swales or other SuDS components under construction. The Developer shall provide within the works where necessary, temporary watercourses, ditches, drains, pumping or other means of maintaining the site clear from standing water.

## 6.6 **EXCAVATIONS WITHIN PROPOSED HIGHWAY LIMITS**

Before construction of the carriageway, footways, or verge is begun, excavations, placement and backfilling for all drains, sewers, cables, ducts or other special formation work shall be completed. This includes the appropriate treatment of any land drains encountered as per Clause 6.7.3.

## 6.7 **GROUND IMPROVEMENT**

### 6.7.1 **Geosynthetics (Geotextile/Geogrid/Geocomposite)**

6.7.1.1 Geotextiles, when used as a separation layer between sub-base and sub-grade, shall be handled and laid as described in this clause and shall comply with the following:-

- (i) They shall be capable of sustaining a minimum tensile load of 15kN/m. This figure shall be ascertained by the Wide Width Strip Test in accordance with BS EN ISO 10319.
- (ii) The geotextile shall have a permeability to water flow at right angles to its plane of not less than 10 litres per m<sup>2</sup> per second under a constant head of water of 100mm. The result will have been determined in accordance with BS EN ISO 11058.
- (iii) The pore O<sub>90</sub> size shall be between 60 and 300 microns. The result will have been determined in accordance with BS EN ISO 12956. The O<sub>90</sub> value refers to the pore size below which lies 90% of the pore sizes in the geotextile.
- (iv) The properties of geotextiles shall be determined at an approved laboratory using agreed test procedures before use in the works. The particular geotextiles to be used in the works shall also be agreed by the Highway and Flood Authority in advance of construction commencing.
- (v) Geotextiles shall be stored so that they will not be damaged by sunlight or ultraviolet light, temporary exposure shall not exceed 5 hours and they shall also be kept free of contamination and not suffer mechanical damage. Where made ground or fill is known to be present within the site, evidence will be required to demonstrate that the geosynthetic will be chemically and biologically resistant to these soils and/or its leachates. An Immersion Test, specific to the site conditions, may be required. Also, confirmation that

the geosynthetic will not release toxic materials will also be required, under both natural conditions or chemical degradation.

- (vi) Geotextiles shall be laid with a minimum 500mm overlap between sheets. The sub-grade must be smooth prior to the rolling out of the geotextile and no trafficking on the geotextile prior to placement of the sub-base or granular layers will be permitted. Furthermore, the only traffic permitted on the sub-base thereafter is that necessary for the construction of the remaining roadworks up to the level approved for trafficking in this specification.
- (vii) When soils are very weak, it will be necessary to additionally incorporate a geogrid see below. Alternatively, an acceptable geocomposite may be installed.
- (viii) The proposed geosynthetics must comply with the CE marking requirements and the Quality Control Certificate(s) will be required for the delivered geosynthetic.

6.7.1.2 Geogrids, used for reinforcement of unbound aggregate in very weak ground when installed between the sub-base or capping layer and the sub-grade shall be handled and laid as described in this clause and shall comply with the following:-

- (i) The Quality Control Strength of the geogrid, when tested in accordance with ISO 10319 and expressed as the lower 95% confidence limit in accordance with ISO 2602 – 1980 (BS 2846, Part 2, 1981), shall be 40kN/m with a peak strain of around 11% in both the longitudinal and transverse directions.
- (ii) In addition, typically the loads at 2% and 5% strain shall be 14kN/m and 28kN/m respectively in both the longitudinal and transverse directions.
- (iii) The ribs of the geogrid shall be of rectangular cross section in both the longitudinal and transverse directions with a nominal edge thickness of 1.35mm.

However, triangular aperture geogrids are available and these must be agreed with the Highway and Flood Authority before installation.

- (iv) The geogrid shall be manufactured from polypropylene sheet, oriented in two directions so that the resulting ribs shall have a high degree of molecular orientation which continues through the area of the integral node.
- (v) The geogrid shall be inert to all chemicals naturally found in soils and shall have no solvents at ambient temperature. It shall not be susceptible to hydrolysis, shall be resistant to aqueous solutions of salts, acids and alkalis and shall be non- biodegradable.
- (vi) The geogrid shall have a minimum of 2% finely divided carbon black, as determined by BS 2782 Part 4, Method 452B: 1993, well dispersed in the polymer matrix to inhibit attack by ultraviolet light.
- (vii) The typical strength of the nodes between the longitudinal and transverse ribs, as determined by the Geosynthetics Research Institute, Drexel University, USA, Test Method GG2-87, shall be at least 90% of the Quality Control Strength in both longitudinal and transverse directions.
- (viii) The geogrid shall be manufactured in accordance with the Quality Assurance requirements BS EN ISO 9001. If required by the Engineer, the Contractor shall provide evidence that the manufacturer's Quality Assurance System has been certified to conform to BS EN ISO 9001 by an external authenticating authority approved by the Department of Trade and Industry.

6.7.1.3 Lincs Laboratory can offer advice on geosynthetic types and sources, the following information will need to be supplied:-

Manufacturer's name; commercial name of geotextile;  
Method of manufacture and constituent materials; mass per unit area;  
Nominal thickness;  
Dimensions and weight of geotextile roll;  
Strength, pore size and permeability - as itemised in sub-paragraphs (i),(ii) and (iii) of this Clause.

- 6.7.1.4 An approved geosynthetic product may also be used to reinforce a thinner than normal pavement foundation as part of a bespoke design agreed with the Highway and Flood Authority. Any proposal to reduce the sub-base thickness must be supported by a specialist report taking into consideration the site investigation findings, the properties of the proposed product, and the following design parameters for the sub-base:-

Traffic loading = 1000 standard axles (1 standard axle = 80kN)  
Maximum permitted rut depth = 40mm

- 6.7.1.5 Geocomposites for installation shall have the combined properties of both a geotextile and a geogrid as described above. Fibreglass strengthened geocomposites will be considered if the strength criteria detailed in 6.7.1.2 are met.

#### 6.7.2 Stabilisation

Where the ground is very weak e.g. the CBR value is less than 1½% stabilisation techniques can be used. For example the addition of lime or lime and cement can be used to increase the strength of cohesive soils and cement can be used to increase the strength of granular soils. Where required, further advice on stabilisation can be obtained by contacting Lincs Laboratory (01522 530355).

#### 6.7.3 Existing Land Drains

Existing land drains that are encountered by the works shall be diverted or if rendered redundant by the works shall be stopped up. Disused ends of intercepted land drains shall be adequately sealed with ST3 (C12/15) concrete.

### 6.8 GRANULAR FILL

Recycled aggregates used in granular fill shall be produced in accordance with the WRAP (The Waste and Resources Action Programme) Quality Protocol produced in conjunction with the Environment Agency: *Aggregate from inert waste*. The results of all quality control checks carried out by the producer shall be compiled in accordance with the procedure set down in the above document. These shall be made available promptly to the Highway and Flood Authority on request.

When recycled aggregate including concrete aggregate is used in accordance with this Clause, it shall not have more than 1% by mass of foreign materials including wood, plastic and metal nor a floating material in volume content exceeding 10cm<sup>3</sup>/kg when tested in accordance with BS EN 933-11 by a suitably trained laboratory technician who has demonstrated competence in classifying the constituent classes in accordance with the test method. Additionally, the aggregate shall not have threshold levels exceeding those in the *ADEPT Guidance Note – Managing Reclaimed Asphalt – Highways and Pavements*.

#### 6.8.1 Construction Charts 1 to 6

- 6.8.1.1 For Construction Charts 1 to 6, the material shall be made and constructed using unbound

mixtures, complying with BS EN 13285, the requirement categories in Table 6/1 and the following classes.

- 6.8.1.2 The material shall be 6F<sub>5</sub> Capping and shall be from a source approved by the Highway and Flood Authority and should comprise crushed rock, crushed concrete, crushed slag or combinations thereof. Secondary materials other than those listed above will be considered on an individual basis.

**Table 6/1: Mixture and Grading Requirement Categories for Capping**

<b>Unbound Mixture</b>	<b>6F5</b>
<b>Clause</b>	6.8
<b>Standard</b>	BS EN 13285 Categories for unbound mixture properties
<b>Mixture requirement</b>	0/80 UF12 OC75
<b>Designation</b>	
<b>Maximum fines</b>	
<b>Over-size</b>	GE
<b>Grading requirement</b>	
<b>- Overall grading</b>	

Unbound mixtures for capping shall conform to requirements A and B below:

- A Mixtures shall conform to the following two criteria:
- (i) Water-soluble sulphate (WS) content determined in accordance with BS EN 1744-1 clause 10 shall not exceed 1500mg of sulphate (as SO<sub>4</sub>) per litre.
  - (ii) Total sulphur (TS) content determined in accordance with BS EN 1744-1 clause 11 expressed as (S) shall not exceed 1% for aggregates other than air cooled blast furnace slag or 2% for air cooled blast furnace slag.
- B Mixtures shall conform to at least one of the following two options:
- (i) When described in accordance with BS EN 932-3 and BS EN 13242 Annex A, limestone, dolomite, blast furnace slag, steel slag or crushed concrete are predominant; or
  - (ii) The sulphide content of the mixture determined in accordance with BS EN 1744-1 Clause 13 is less than 0.5% (as SO<sub>4</sub>)

Unbound mixtures placed within 500mm of metallic structural elements forming part of the Permanent Works shall conform to requirements C and D below:

- C Mixtures shall conform to the following two criteria:
- (i) Water-soluble sulphate (WS) content determined in accordance with BS EN 1744-1 clause 10 shall not exceed 300mg of sulphate (as SO<sub>4</sub>) per litre.
  - (ii) Total sulphur (TS) content determined in accordance with BS EN1744-1 clause 11 expressed as (S) shall not exceed 1% for aggregates other than air cooled blast

furnace slag or 2% for air cooled blast furnace slag.

D Mixtures shall conform to at least one of the following two options:

- (i) When described in accordance with BS EN 932-3 and BS EN 13242 Annex A, limestone, dolomite, blast furnace slag, steel slag or crushed concrete are predominant;  
or
- (ii) The sulphide content of the mixture determined in accordance with BS EN 1744-1 Clause 13 is less than 0.06% (as SO<sub>4</sub>)

Aggregates used in unbound mixtures shall comply with the selected requirements of BS EN 13242 listed in Table 6/2.

**Table 6/2: Requirements for Aggregates used in Capping**

<b>Unbound mixture</b>	<b>Capping</b>
<b>Clause</b>	6.8
<b>Standard</b>	BS EN 13242 Categories for aggregate properties
<b>Crushed, or broken and totally rounded particles</b>	NR (no requirement)
- crushed rock	
<b>Resistance to fragmentation – Los Angeles test</b>	LA60
<b>Resistance to wear –micro-Deval test</b>	MDENR (no requirement) The supplier shall state the value for the aggregate used.
<b>Water absorption</b>	WA24NR (no requirement) The supplier shall state the value for the aggregate used.
<b>Volume stability of blast furnace slags</b>	Free from dicalcium silicate and iron disintegration.
<b>Volume stability of steel (BOF and EAF) slags</b>	V5
<b>All other BS EN 13242 aggregate requirements</b>	Category NR (no requirement)

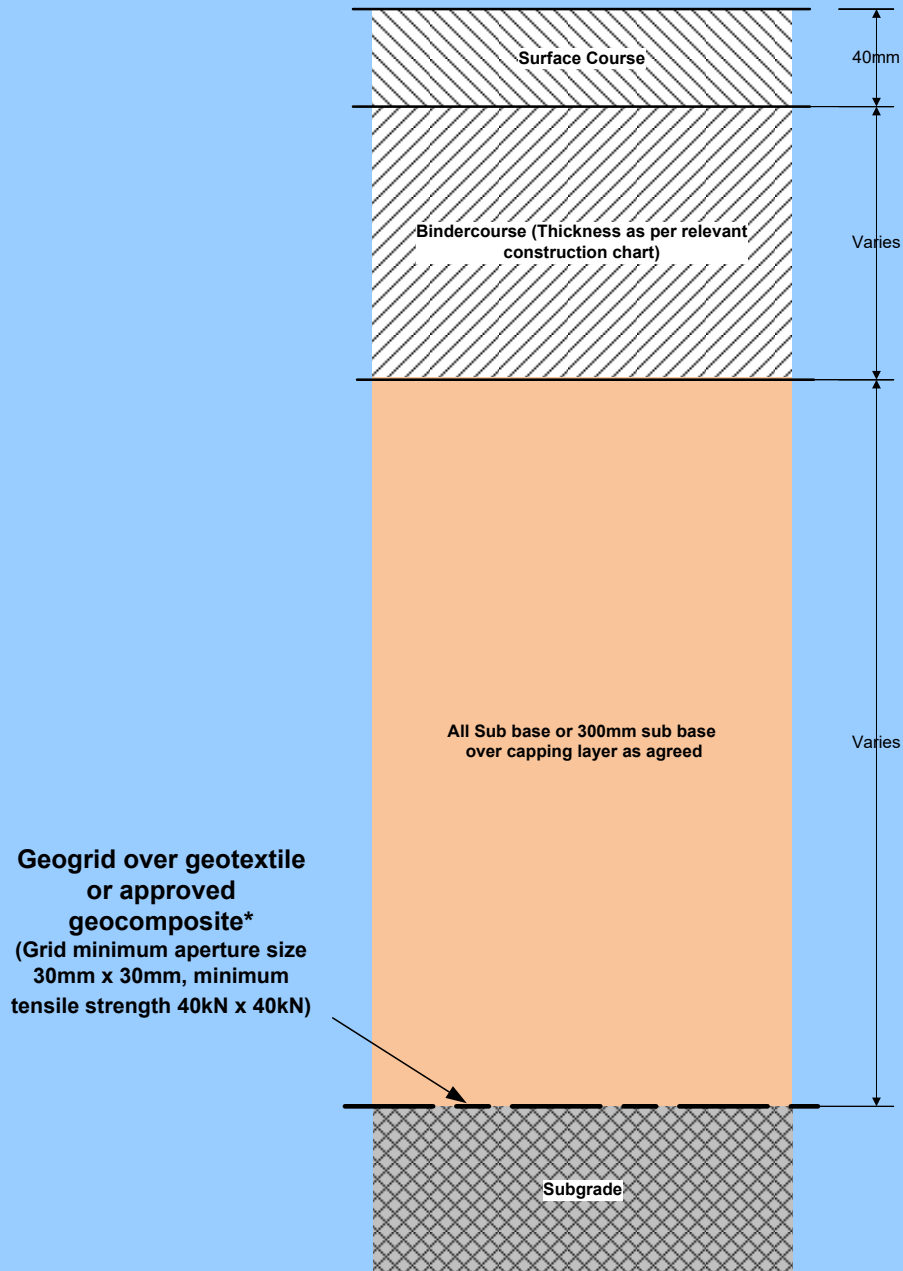
**Table 6/3: Summary Grading Requirements  
for Granular Fill 6F<sub>5</sub> Capping Layer**

<b>Sieve Sizes mm</b>	<b>Percentage by Mass Passing</b>
125	100
80	75-99 <sup>1</sup>
40	50-90
20	30-75
10	15-60
2	0-35
0.063	0-12

Note 1: The percentage passing 80mm may be greater than 99% but in such cases the supplier shall declare the typical grading.

- 6.8.1.3 6F<sub>5</sub> Capping Layer material shall be transported, laid and compacted at a water content, determined in accordance with BS EN 1097-5 in order that such compaction can be achieved that an equivalent in situ CBR value, determined by the plate bearing test, of >15% is attained at the surface of the finished layer.
- 6.8.1.4 The 6F<sub>5</sub> Capping Layer materials shall be laid in one or more layers, each not exceeding 225mm compacted thickness appropriate to the compaction plant used (whichever is the lesser) to give the specified total depth and width of granular fill. Each layer should be placed and spread evenly without delay.

**FIGURE 6/1 – TYPICAL ROAD SECTION SUBGRADE CBR LESS THAN 1.5%**



**All services within the carriageway to be installed within the subgrade.  
Bespoke designs for subgrade reinforcement must be agreed with the Highway and  
Flood Authority.**

## 7. ROADWORKS - OVERALL REQUIREMENTS

---

### 7.1 HORIZONTAL ALIGNMENT, SURFACE LEVELS, LAYER THICKNESSES AND SURFACE REGULARITY

- 7.1.1 Highways England's requirements for horizontal alignments, surface levels of pavement courses and surface regularity are replaced by this Clause.
- 7.1.2 If the works do not comply with the requirements of this Clause, rectification shall be in accordance with the requirements of the Highways England's current Specification for Highway Works as modified by this Clause or as may be otherwise agreed in writing by the Highway and Flood Authority.
- 7.1.3 Horizontal alignment as shown on the drawings, shall be determined from the edge of the carriageway pavement surface, as shown on the drawings. The edge of the carriageway as constructed and all other parallel alignments shall be correct within a tolerance of plus/minus 13mm.
- 7.1.4 **The installation of kerbs shall be prior to Binder Course being placed as specified in Clause 10.1 unless an alternative method of working as specified in Clause 1.1.17 is employed which will require the binder course to be laid in two separate stages.**
- 7.1.5 The level of any point on the surface of each of the pavement courses of the carriageway, footway or vehicle crossing, (i.e. the true level as specified), after completion of compaction, shall conform to that shown on the drawings and shall be within the tolerances shown below:-

**Table 7/1  
Tolerances in surface levels of Pavement Courses**

<b>Course</b>	<b>Tolerance from specified levels (mm)</b>
<b>Sub-Base</b>	+10 - 30
<b>Binder Course</b>	$\pm 6$
<b>Block Paving Laying Course</b>	$\pm 6$
<b>Surface Course including Block Paving</b>	$\pm 6$

The tolerances for pavement courses shall be within those shown below.



**Table 7/2  
Tolerances for Pavement Courses**

<b>Course</b>	<b>Tolerance from specified layer thicknesses(mm)</b>
<b>Sub-Base</b>	- 0 + 40
<b>Binder Course</b>	+ -6
<b>Block Paving Laying Course</b>	+ -6
<b>Surface Course including Block Paving</b>	+ -6

7.1.6 Furthermore, the combined thickness of surfacing (bituminous materials or bituminous Binder Course materials and block paving) shall not be reduced in thickness by more than 6mm from that specified.

7.1.7 In addition, when tested with the TRL Rolling Straight Edge on any line, irregularities must not exceed those given below:-

**Table 7/3  
Tolerances - TRL Rolling Straight Edge**

Irregularity	Surface Course				Binder Course			
	4mm		7mm		4mm		7mm	
Traverse length (metres)	300	75	300	75	300	75	300	75
Number of irregularities	20	9	2	1	40	18	4	2

**No irregularities shall exceed 10mm**

For works of lengths of between 75m and 300m the maximum permitted irregularities shall be calculated by a pro-rata scaling down (to a zero base length) of the 300m permitted number of irregularities.

For works of lengths less than 75m the maximum permitted irregularities shall be calculated by a pro-rata scaling down of the 75m length permitted number of irregularities

For block paving the surface shall not deviate by more than 10mm under a 3metre straight edge. The difference in level at the joints of adjacent paving units shall not exceed 2mm.

**7.2 COMPACTION OF BITUMINOUS MATERIALS**

7.2.1 The choice of materials, design of mix and method of laying shall be consistent with obtaining mechanical key and physical adhesion between all new layers and obtaining cohesion throughout. Cohesion/adhesion shall be assessed from 150mm diameter cores cut into the material when cold and shall be deemed to exist when detachment does not occur with the core suspended vertically for one minute. Compliance with this requirement must be obtained at all times after laying and will be deemed to occur when no more than 1 in 10 cores taken from any area fail the above test.

- 7.2.2 The material shall be uniformly compacted by an appropriate roller capable of meeting the air void requirements across the full width of the material. 8 to 10 tonne smooth wheel rollers, multi-wheeled pneumatic tyred rollers or double driven vibrating rollers (2 tonnes minimum dead weight) may be used provided that the surface level of pavement courses meet the requirements of Clause 7.1.
- 7.2.3 The compaction process of Binder Course shall be controlled on site by the use of an Indirect Density Gauge (IDG). The use of an IDG on Surface Courses is optional. It is essential the surfacing contractor knows the target density for the particular material being laid and through this information he should be able to demonstrate **potential** compliance with the specification requirements. **The Indirect Density Gauge will not measure the absolute density of the material being laid, this can only be determined by the taking of cores.** It is however, good at indicating the maximum gauge density that can be achieved on site for the particular conditions prevailing at the time. That density will be influenced by temperature, climatic conditions and whether the roller type selected is operating in accordance with the manufacturer's recommendations both for frequency and operating speed. The layer thickness and the actual composition of the material can also influence the ultimate density and thereby air voids reported from the cores tests.
- 7.2.4 Calibration of the IDG shall be carried out in general agreement with **Clauses 2.5.5.3.2 and 2.5.5.3.3 of BS1377: Part 9.** Compliance with the Specification, in the case of bituminous materials, will be assessed from waxed cores in accordance with BS EN 12697-6.
- 7.2.5 Attention is particularly drawn to the mixing temperatures given in BS EN 13108-1 and BS EN 13108-4, the temperatures given in BS 594987, and the rolling temperatures summarised in the following table:-

**Table 7/4**

Material	Binder Grade	Temperature		
		BS EN Maximum on Mixing	BS Minimum on Delivery	Min on Rolling
Dense and Close Graded Bitumen Asphalt	40/60	190	130	100
	70/100	180	130	95
	100/150	170	120	95
Hot Rolled Asphalt Surface	40/60	190	140	100

- 7.2.6 It should be noted that 6mm size Dense Surface Course Asphalt Concrete when used as a footway Surface Course is particularly sensitive to adverse laying conditions. The risk of failing to comply with the end performance requirements contained in this specification will be significantly increased when laying during adverse weather conditions occurs, or the compaction process is not completed by the minimum rolling temperature above. Working methods should be reviewed in cold weather in order to minimise rapid cooling of delivered materials.
- 7.2.7 The choice of materials, design of the mix and method of laying shall ensure that the air voids of compacted bituminous materials shall comply with the following table:-

**Table 7/5**

Material	AIR VOIDS %		
	Normal Range 1	1 in 10 Max 2	Absolute Max 3
Footway Dense Binder Course	2 – 10	10	12
Footway Dense Surface Course	2 – 10	10	12
Carriageway Dense Binder Course	2 – 8	8	10
Carriageway Close Graded Surface Course	2 – 10	10	12
Carriageway Hot Rolled Asphalt Surface Course	2 – 6	6	8
<p><u>Notes</u></p> <p>1 No results are permitted with air voids below 2%</p> <p>2 Not more than 1 in 10 results permitted above this value</p> <p>3 No values permitted above this value. This includes any for cores extracted wholly within 250mm or less from a joint</p>			

### **7.3 Air Voids and Bond**

- 7.3.1 Cores shall be extracted in accordance with BS EN 12697-27 and shall be 150mm diameter. Core densities shall be determined on core specimens in a dried condition having been oven dried at 40°C to constant mass and in accordance with BS EN 12697-6. Cores of asphalt concrete or thin surface course shall be tested in a waxed condition, Procedure C. Cores of Hot Rolled Asphalt shall be tested to Procedure A. Determination of bond, thickness and air voids shall be conducted in accordance with an approved in-house method. Air voids shall be determined in accordance with BS EN 12697-8
- 7.3.2 To gain approval for an in-house test method the test house shall forward a copy of the appropriate in-house test method to the Highway and Flood Authority. This should be done prior to any testing being carried out using the in-house test method.

### **7.4 COLD WEATHER WORKING**

- 7.4.1 No material in a frozen condition may be incorporated in the Works.
- 7.4.2 Material for use in road pavements shall not be laid on any surface which is frozen or covered in ice.
- 7.4.3 Except for hot rolled asphalt surface course, the laying of materials containing bitumen binder shall cease if the temperature of the surface to be covered is at, or falls below, 2°C. If the surface is dry, unfrozen and free from ice, laying may proceed at air temperatures at or above 1°C provided the temperature is rising.
- 7.4.4 Laying of hot rolled asphalt shall cease if the temperature of the surface to be covered is at, or falls below, 5°C or if the still air temperature in the shade falls below 8°C. Attention is particularly drawn to the additional 'wind chill' factor in cold weather working conditions. Further guidance is published in the Transport Research Laboratory's (TRL) Report No. 4 (1985)

"Cooling of Bituminous Layers and Time Available for Their Compaction".

- 7.4.5 Thin Surface Course systems shall be laid in accordance with the requirements, including weather conditions, as given in the agreed specification for the particular system.

## **7.5 USE OF SURFACE BY CONSTRUCTIONAL PLANT**

Constructional plant shall be suitable in relation to the thickness of the pavement course to be traversed so that damage to the pavement course of the carriageway or the sub-grade material is not caused. The wheels or tracks of plant moving over the various pavement courses must be kept free from harmful deleterious material such as mud, clay etc.

## **7.6 RECTIFICATION**

- 7.6.1 Where any carriageway or footway does not comply with this specification, the non-compliant area shall be made good and surfacing rectified in accordance with the Highways England's current Specification for Highway Works except:-

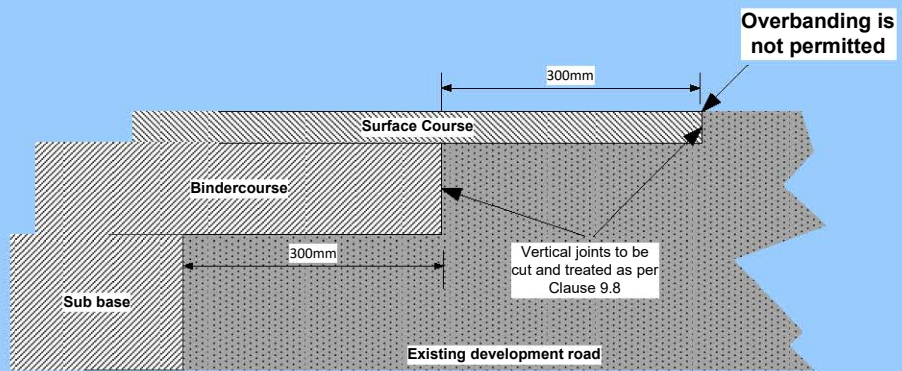
- 7.6.2 Where non-compliant binder course surface levels require rectification, this shall be achieved by at least partial removal and replacement of the existing binder course layer. This shall be achieved by planing or otherwise removing, by a method agreed with the Highway Authority, sufficient material to enable a replacement layer of binder course to be installed. For carriageways, the replacement binder course layer shall have a compacted thickness of at least 60mm. For footways the equivalent thickness is 50mm. The use of shaping/regulating material is not permitted.

- 7.6.3 If an area of carriageway surface course requires rectification, a minimum 5m length of at least half carriageway width shall be replaced.

For footway surface course, the minimum replacement length is 2m for the full width of footway.

Attention is drawn to the requirements of Clause 1.1.17.4.

**FIGURE 7/1 – JOINTS WITH EXISTING CARRIAGEWAYS  
WITHIN SECTION 38 DEVELOPMENTS**



## 8. SUB-BASE

### 8.1 AGGREGATE FOR SUB-BASE

8.1.1 Sub-base shall be made and constructed using unbound mixtures complying with BS EN 13285, the requirement categories in Table 8/1 and the following Clauses.

Recycled aggregates used in unbound mixtures for sub-base shall be produced in accordance with the WRAP (The Waste and Resources Action Programme) Quality Protocol produced in conjunction with the Environment Agency: *Aggregate from inert waste*. The results of all quality control checks carried out by the producer shall be compiled in accordance with the procedure set down in the above document. These shall be made available promptly to the Highways and Flood Authority on request.

When recycled aggregate including concrete aggregate is used in accordance with this Clause, it shall not have more than 1% by mass of foreign materials including wood, plastic and metal when tested in accordance with BS EN 933-11 by a suitably trained laboratory technician who has demonstrated competence in classifying the constituent classes in accordance with the test method. Additionally, the aggregate shall not have threshold levels exceeding those in the *ADEPT Guidance Note – Managing Reclaimed Asphalt – Highways and Pavements*.

**Table 8/1: Mixture and Grading Requirement Categories for Unbound Mixtures for Sub-base**

Unbound Mixture	Type 1	Type 3 Open Graded
Clause	8.1	8.1
Standard	BS EN 13285 Categories for unbound mixture properties	BS EN 13285 Categories for unbound mixture properties.
Mixture requirement category		
Designation	0/31.5	0/40
Maximum fines	UF <sub>9</sub>	UF <sub>5</sub>
Oversize	OC <sub>75</sub>	OC <sub>80</sub>
Grading requirement category	G <sub>p</sub>	G <sub>o</sub>
Overall grading		
Void Ratio	N/A	Minimum 15% to 25%

Unbound mixtures shall conform to requirements A and B below:

A Mixtures shall conform to the following two criteria:

- (i) Water-soluble sulphate (WS) content determined in accordance with BS EN 1744-1 clause 10 shall not exceed 1500mg of sulphate (as SO<sub>4</sub>) per litre.
- (ii) Total sulphur (TS) content determined in accordance with BS EN 1744-1 clause 11 expressed as (S) shall not exceed 1% for aggregates other than air cooled blast furnace slag or 2% for air cooled blast furnace slag.

B Mixtures shall conform to at least one of the following two options:

- (i) When described in accordance with BS EN 932-3 and BS EN 13242 Annex A, limestone, dolomite, blast furnace slag, steel slag or crushed concrete are predominant; or
- (ii) The sulphide content of the mixture determined in accordance with BS EN 1744-1 Clause 13 is less than 0.5% (as SO<sub>4</sub>)

When determining WS, TS or sulphide content, at least five samples of each material shall be tested. The mean of the highest two values shall be used for comparison with limiting values. The also applies if six to nine results are available. If ten or more results are available, the mean of the highest 20% of the results shall be used for comparison with limiting values. The pH of the mixture shall be reported.

Unbound mixtures placed within 500mm of metallic structural elements forming part of the Permanent Works shall conform to requirements C and D below:

C Mixtures shall conform to the following two criteria:

- (i) Water-soluble sulphate (WS) content determined in accordance with BS EN 1744-1 clause 10 shall not exceed 300mg of sulphate (as SO<sub>4</sub>) per litre;
- (ii) Total sulphur (TS) content determined in accordance with BS EN1744-1 clause 11 expressed as (S) shall not exceed 1% for aggregates other than air cooled blast furnace slag or 2% for air cooled blast furnace slag.

D Mixtures shall conform to at least one of the following two options:

- (i) When described in accordance with BS EN 932-3 and BS EN 13242 Annex A, limestone, dolomite, blast furnace slag, steel slag or crushed concrete are predominant; or
- (ii) The sulphide content of the mixture determined in accordance with BS EN 1744-1 Clause 13 is less than 0.06% (as SO<sub>4</sub>)

When determining the WS, TS or sulphide content, at least five samples of each material shall be tested. The mean of the highest two values shall be used for comparison with the limiting values. This also applies if six to nine results are available. If ten or more results are available, the mean of the highest 20% of the results shall be used for comparison with the limiting values. The pH of the mixture shall be reported.

Aggregates used in unbound mixtures shall comply with the selected requirements of BS EN 13242 listed in Table 8/2.

**Table 8/2: Requirements for Aggregates Used in Unbound Mixtures for Sub-Base**

Unbound mixture	Type 1	Type 3 Open Graded
<b>Clause</b>	8.1	8.1
<b>Standard</b>	BS EN 13242 Categories for aggregate properties	
<b>Crushed, or broken and totally rounded particles</b>	C <sub>90/3</sub> – see Note 1	C <sub>90/3</sub> – see Note 1
<b>-Crushed rock</b>		
<b>Resistance to fragmentation – Los Angeles test</b>	LA <sub>50</sub>	LA <sub>30</sub>
<b>Resistance to wear – micro – Deval test</b>	M <sub>DE</sub> NR (no requirement) The supplier shall state the Value for the aggregate used.	M <sub>DE</sub> 20
<b>Resistance to freezing and thawing – Magnesium sulphate soundness</b>	MS <sub>35</sub>	MS <sub>18</sub>
<b>Water absorption</b>	WA <sub>24</sub> NR (no requirement) The supplier shall state the value for the aggregate used.	WA <sub>24</sub> <sup>2</sup>
<b>Volume stability of blast furnace slags</b>	Free from dicalcium silicate and iron disintegration.	Free from dicalcium silicate and iron disintegration.
<b>Volume stability of steel (BOF and EAF) slags</b>	V <sub>5</sub>	V <sub>5</sub>
<b>All other BS EN 13242 aggregate requirements</b>	Category <sub>NR</sub> (no requirement)	Category <sub>NR</sub> (no requirement)
<b>Notes</b>		
1. BS EN 13242 assumes that crushed rock aggregates comply with C <sub>90/3</sub> without further testing		

8.1.2 Recycled aggregates used in unbound mixtures for sub-base shall be produced in accordance with the WRAP (The Waste and Resources Action Programme) Quality Protocol produced in conjunction with the Environment Agency: *Aggregate from inert waste*. The results of all quality control checks carried out by the producer shall be compiled in accordance with the procedure set down in the above document. These shall be made available promptly to the Highways and Flood Authority on request.

When recycled aggregate including concrete aggregate is used in accordance with this Clause, it shall not have more than 1% by mass of foreign materials including wood, plastic and metal nor a floating material in volume content exceeding 10cm<sup>3</sup>/kg when tested in accordance with BS EN 933-11 by a suitably trained laboratory technician who has demonstrated competence in classifying the constituent classes in accordance with the test method. Additionally, the aggregate shall not have threshold levels exceeding those in the *ADEPT Guidance Note – Managing Reclaimed Asphalt – Highways and Pavements*.

8.1.3 All sub-base materials shall have a laboratory bearing capacity ratio (CBR) of not less than 30% when tested in accordance with Method 2 of BS1377 Part 4 with the following provisos:-

8.1.4 Compaction in accordance with Clause 7.2.4.5 of BS1377 Part 4. The material tested shall all pass a 20mm sieve irrespective of the amount of material retained on the 20mm sieve.

8.1.5 The material shall be compacted and subsequently tested at a water content within –2% and



+1% of the optimum water content determined in accordance with BS EN 13286-4. Four surcharge weights shall be used.

- 8.1.6 Sub-base after compaction when tested in-situ with plate bearing equipment must meet the equivalent CBR value (Clause 1.2) specified for that particular road type, when tested by a method approved by the Highway and Flood Authority.
- 8.1.7 Type 1 and Type 3 unbound mixtures for sub-base shall be from a source approved by the Highway and Flood Authority and be made from crushed rock, crushed slag, crushed concrete, recycled aggregates or well burnt non-plastic shale or a combination thereof and may contain up to 10% mass of natural sand that passes the 4mm test sieve. Secondary materials other than those listed above may be used if approved by the Highway and Flood Authority.
- 8.1.8 The mixture shall comply with BS EN 13285 and the requirements of Table 8/1. The grading requirements for Type 1 mixture are summarised in Table 8/5. Those for Type 3 mixtures are summarised in Table 8/6

**Table 8/5: Summary Grading Requirements for Type 1 Unbound Mixtures for Sub-base**

Sieve size (mm)	Percentage by mass passing		
	Overall grading range	Supplier declared value grading range	Tolerance on the supplier declared value
63	100		
31.5	75-99		
16	43-81	54-72	□15
8	23-66	33-52	□15
4	12-53	21-38	□15
2	6-42	14-27	□13
1	3-32	9-20	□10
0.063	0-9		
Grading of individual batches – differences in values passing selected sieves			
Retained sieve size,(mm)	Passing sieve size (mm)	Percentage by mass passing	
		Not less than	Not more than
8	16	7	30
4	8	7	30

**Table 8/6: Summary Grading Requirements for Type 3 Open Graded Mixtures for Sub-base for Construction 7 Chart Roads.**

Sieve size (mm)	Percentage by mass passing		
	Overall grading range	Supplier declared value grading range	Tolerance on the supplier declared value
80	100		
40	80-99		
20	50-78	58-70	□ 8
10	31-60	39-51	□ 8
4	18-46	26-38	□ 8
2	10-35	17-28	□ 7
1	6-26	11-21	□ 5
0.500	0-20	5-15	□ 5
0.063	0-5		
Grading of individual batches – differences in values passing selected sieves			
Retained sieve size (mm)	Passing sieve size (mm)	Percentage by mass passing	
		Not less than	Not more than
10	20	10	25
4	10	10	25
2	4	7	20
1	2	4	15

Aggregates used in the mixtures shall comply with BS EN 13242 and the requirements of Table 8/2.

The size fraction of the unbound mixture passing the 0.425mm size test sieve shall be non-plastic as defined by BS 1377:Part 2 and tested in compliance therewith.

- 8.1.9 The material shall be transported, laid and compacted at a moisture content within the range 1% above to 2% below the optimum water content determined in compliance with BS EN 13286-4 and without drying out or segregation.
- 8.1.10 The material shall be uniformly compacted by an appropriate roller capable of meeting the density and bearing capacity requirement across the full width of the carriageway. 8-10 tonnes smooth wheeled rollers or double driven vibrating rollers (2 tonnes minimum dead weight) may be used for the carriageway provided that the surface level of the sub-base meets the requirements of Clause 7.1.
- 8.1.11 Not more than one field dry density determination in ten shall be less than 90% of the maximum dry density for that particular sub-base as determined by the vibrating hammer test in BS EN 13286-4. This requirement applies to footways and vehicle crossings as well as carriageways.
- 8.1.12 The layer(s) when tested in situ with plate bearing equipment must meet the equivalent CBR requirement specified for that particular road type.
- 8.1.13 For frost heave, materials shall be tested in accordance with BS 812: Part 124 as amended by Clause 801 of the Specification for Highway Works, Volume 1, except that the use of the silica sand and limestone filler reference specimens is not mandatory.
- 8.1.14 Sub-base up to 225mm compacted thickness shall be spread in one layer so that after compaction the total thickness is as specified. Sub-base material of compacted thickness greater than 225mm shall be laid in two or more layers and the minimum compacted thickness

of any such layer shall be 110mm. Where the layers of sub-base material are of unequal thickness the lowest layer shall be the thickest layer.

## 8.2 PLATE BEARING TEST

8.2.1 Plate Bearing and/or Light Drop Weight testing shall be conducted to assess the adequacy of the compacted sub-base prior to the installation of the binder course.

The testing must be carried out:-

- (i) To a procedure approved by the Highway and Flood Authority
- (ii) In such a manner that the values obtained are representative of the full depth of sub-base placed
- (iii) At least 5 working days prior to the application of the Binder Course and
- (iv) At a sufficient number of locations.

8.2.2 For Plate Bearing Testing the locations should normally be spaced between 50 metres and 100 metres apart and a minimum of 2 locations is required. Each sub-base source sub-base and type must be tested. A mobile kentledge of 10 tonnes will be required. Normally the plate diameter will be between 100mm and 300mm depending upon the thickness under test.

8.2.3 Prior to conducting Plate Bearing Tests the Test House shall submit details of the Test Procedure to be used to the Highway and Flood Authority. Testing shall not take place until the Test House has received approval for the proposed Test Procedure.

8.2.4 Load gauges and movement gauges will be required to be properly calibrated. The method of calculating equivalent CBR from the Modulus of Sub-grade Reaction will require to be detailed within the Test Procedure submitted for approval. The report should give first loading CBR% and EV1, second loading EV2 and the EV2/EV1 ratio (where EV = The Modulus of Deformation).

8.2.5 The bearing capacity in terms of stiffness of the finished sub-base is established by the use of a dynamic (light) plate loading technique such as Light Drop Weight Tester (Dynamic Plate Tester). Such devices shall have previously been calibrated against the plate bearing apparatus **for the particular type of material under test**. Evidence of this comparative testing will be required by the Highway Authority. Details of the source and type of material and aggregate being tested will be required.

The distance between locations tested by the dynamic plate tester shall not exceed 20 metres.

Each sub-base source and sub-base type shall be tested.

All dynamic plate loading tests must be carried out to a procedure approved by Lincolnshire County Council.

A minimum value of 35MPa is required for sub-base tested using this method

For compliance purposes i.e. resolution of disputes, the Plate Bearing Test is the definitive method.

## 9. FLEXIBLE SURFACING

---

### GENERAL

Bituminous Surface Course surfacings of carriageways and footways shall not be laid until building development is complete or at such an advanced stage that damage will not occur, notwithstanding any requirements under Section 38 of the Highways Act 1980.

#### 9.1 DENSE BINDER COURSE

This material shall be AC 20 dense bin rec to BS EN 13108-1. The binder shall conform to BS EN 12591 **grade 40/60** for carriageway construction. For vehicle crossings the binder shall be either 40/60, 70/100 or 100/150 grade and for footways 70/100 or 100/150 grade.

#### 9.2 BOND AND TACK COATS

When required a bond coat complying with BS 594987:2015 Clause 5.5 shall be used. The bond coat shall comply with BS EN 13808:2013, Table 4, Clause 4 and shall be applied in accordance with BS 594987:2015 Clause 5.5.2. When a bond coat is not required a C40B4 (K1-40) or C60B3 (K1-60) tack coat of cationic bitumen emulsion to BS EN 13808 shall be applied to accord with the target rates given in BS 594987 Annex J to the binder course surface. The surface should be thoroughly cleaned prior to the application of the tack coat and the emulsion allowed to 'break' prior to the application of a further layer of binder course or the surface course.

#### 9.3 CLOSE GRADED SURFACE COURSE FOR CARRIAGEWAYS

This material shall be AC 10 close surf to BS EN 13108-1. The binder shall conform to BS EN 12591 grade 70/100 or 100/150. Unless otherwise agreed by the Highway Authority, the minimum PSV of the coarse "hardstone" aggregate shall be 55 and the aggregate shall be from a source classified as such by the Lincolnshire County Council Approved Supplier Information Booklet current at the time of the works.

#### 9.4 DENSE SURFACE COURSE FOR FOOTWAYS

This material shall be BS EN 13108-1 AC 6 dense surf.  
The binder shall conform to BS EN 12591 grade 70/100 or 100/150.

#### 9.5 CLOSE GRADED SURFACE COURSE FOR TEMPORARY FOOTWAYS.

The material shall be BS EN 13108-1 AC14 close surf.  
The binder shall conform to BS EN 12591 grade 100/150

#### 9.6 ROLLED ASPHALT SURFACE COURSE

Rolled Asphalt Surface Course shall be BS EN 13108-4 HRA 30/14F surf 40/60 des.

The mix shall be either LCC Special Mix or LCC Standard Mix and classified as such by the Lincolnshire County Council Approved Supplier's Information Booklet.

The binder shall be grade 40/60 (50 pen) bitumen. The coarse aggregate content of the mix shall be 30%. The minimum PSV value for coarse aggregate in the mix shall be not less than 45.

## 9.7 **COATED CHIPPINGS**

9.7.1 Coated chippings shall be 14/20mm size as described in this Clause and shall comply with BS EN 13108-4. The minimum PSV shall be 60 unless a higher value is specified by the Highway and Flood Authority. The aggregate shall be from a source classified to provide the required PSV by the Lincolnshire County Council Approval Suppliers Booklet current at the time of the works.

9.7.2 Coated chippings must be delivered to the site at least four working days in advance of laying the surface course. The Contractor is advised to use chippings that have been tested and approved by Lincs Laboratory.

**Table 9/1: Requirements for Aggregate used as Coated Chippings**

Property	Category
Grading	14/20 G <sub>C</sub> 85/20
Fines content	$f_2$
Flakiness index	$Fl_{20}$
Resistance to fragmentation	$LA_{30}$
PSV	60 (min)
AAV	12
Durability: Water absorption to BS EN 1097-6:2000, Clause 7 - For $WA > 2\%$ , magnesium sulfate soundness	$WA_{242} MS_{25}$

**Table 9/2: Grading Requirements for Coated Chippings**

Grading of Chippings	
Test Sieve Size	Percentage by mass passing sieve test
40mm	100
31.5mm	98 to 100
20mm	85 to 99
14mm	0 to 20
6.3mm	0 to 5
0.063mm	0 to 2

9.7.3 The binder to coat the chippings shall be 40/60 grade conforming to BS EN 12591. The target binder content shall not be less than 1,5%.

9.7.4 Texture depth will be measured using the WDM Texture Meter 2 (TM2), to determine the average Sensor Measured Texture Depth (TM2 SMTD). Measurements will be measured over one or more sections of carriageway lane 50m in length, or the complete carriageway lane if

less than 50m. The minimum length will be 10m. The average texture depth for any section of Rolled Asphalt Surface Course shall be in the range of 0.75mm to 1.30mm (TM2 SMTD) throughout the maintenance period.

## **9.8 JOINTS IN BITUMINOUS CONSTRUCTION**

All joints shall be made in accordance with BS 594987 Clause 6.8 and in particular the following:-

When possible all joints shall be offset by at least 300mm from parallel joints in the layer beneath.

All longitudinal and transverse joints in surface courses shall be made flush.

Before the adjacent width is laid, surface course joints shall be made by:

- a) cutting back the edge to a vertical face that exposes the full thickness of the layer; and
- b) discarding all loosened material and painting or spraying the vertical face completely with a thin uniform coating of hot applied 40/60 or 70/100 paving grade bitumen, or cold applied thixotropic bituminous emulsion of similar grade or polymer modified bitumen emulsion bond coat.

Surface course joints made in this way shall be:-

- All transverse joints that have not been formed to a specific profile;
- Joints where the asphalt abuts an existing surface; and
- All longitudinal joint.

NOTE 1: Longitudinal joints in surface course may also be formed by use of an edge compactor creating a chamfered edge during the laying process. Cutting back of the longitudinal joint is not necessary in this instance.

NOTE 2: Surplus bitumen on the surface after the joint is made should be avoided. The surface of the finished joint should not be painted because of the risk of skidding and slipping.

Joints in the binder course shall be treated in such a way as to enhance compaction and bonding.

NOTE: For example by use of edge compactors fitted to rollers.

## **9.9 RECYCLED MATERIAL**

Up to 10% of crushed recycled bituminous material may be included as an aggregate replacement in Binder Course mixes. Only plants that are approved to supply Binder Course with a recycled element will be permitted to supply such materials. These materials shall comply with Clause 9.10. Details of approved plants can be obtained from Lincs Laboratory.

## **9.10 RESIDUAL BINDER PENETRATION**

For all bituminous asphaltic concretes and asphalts made with unmodified bitumen the recovered binder penetration value, from site sampled material, shall be numerically not less than 60% of the nominal value nor more than the nominal value e.g. for a specified 50 pen (40/60 grade) binder the recovered binder shall be in the range of 30 pen to 50 pen.

## **9.11 Not used**

## **9.12 ANNEX B**

### **BS EN 13108-1 Asphalt concrete-Specification**

#### **Annex B**

This annex contains the specification for asphalt concrete in accordance with BS EN 13108-1 for use on adoptable highways built in accordance with this specification.

#### **Specification for asphalt concrete**

### **B.1 General**

Asphalt concrete (Macadam type) mixture shall conform to BS EN 13108-1. Conformity shall be established in accordance with BS EN 13108-20 and BS EN 13108-21.

#### **Constituent materials**

### **B.2 Binder**

The binder shall be paving grade bitumen conforming to BS EN 12591.

#### **B.2.2 Bitumen**

##### **B.2.2.1 Paving grades**

The paving grades for asphalt concrete are 40/60, 70/100 and 100/150.

*NOTE 1 70/100 and 100/150 pen paving grade bitumen may be produced by blending in the mixer at the asphalt plant.*

The grades used for blending shall be no harder than 30/45 pen, nor softer than 160/220 pen and shall conform to BS EN 12591. The producer shall be able to demonstrate that the plant is capable of adequately blending the bitumens. Measures for ensuring consistency of proportioning of the blend shall be included in plant quality management systems. These shall include evidence of type tests carried out on a laboratory blend of the bitumens to demonstrate conformity to BS EN 12591. The quality assurance / management systems shall also include the steps to be taken to demonstrate the continuing adequacy of the process following significant changes being made to those parts of the plant involved in the process of bitumen blending. No grades of bitumen harder than 70/100 pen shall be blended in the mixer.

*NOTE 2. Other grades may be in-plant blended provided that the resulting bitumen can be sampled and tested before it is added to the aggregate and to ensure it conforms to BS EN 12591.*

### **B.2.3 Not used**

## **B.2.4 Aggregates**

### **B.2.4.1 Coarse aggregate**

#### **B.2.4.1.1 Type of coarse aggregate**

Coarse aggregate shall be material substantially retained on a 2mm test sieve, conforming to all appropriate requirements of BS EN 13043 and consisting of one of the following.

- a) Crushed rock of one or more of the following groups; basalt, gabbro, granite, gritstone, hornfels, limestone, porphyry or quartzite.
- b) Gravel of one or more of the groups in a) or flint, crushed or uncrushed, or combinations of both types.
- c) When gravel other than limestone gravel is used, 2% by mass of the total aggregate of either hydrated lime or cement shall be used as a filler.
- d) Blast furnace slag.
- e) Steel slag, either electric arc furnace slag or basic oxygen slag, with a compacted bulk density between 1,60 Mg/m<sup>3</sup> and 1.80 Mg/m<sup>3</sup> when tested in accordance with BS 812-2.

#### **B.2.4.1.2 Particle shape**

The flakiness category for aggregates for all macadam type mixtures shall be F135.

#### **B.2.4.1.3 Fines content**

The fines content for coarse aggregates shall be:

- a) for crushed rock/slag:  $f_{NR}$ ; and
- b) for gravel:  $f_1$ .

Where there is a requirement in this specification for AAV and/or PSV for the coarse aggregate component of the mixture, the values apply to the aggregate proportion retained on the 4mm sieve.

*NOTE 2 The use of 2% by mass of the total aggregate of hydrated lime or cement filler reduces the risk of water stripping the binder from some aggregates, in particular flint gravel. This might also be achieved by the addition of adhesion agents to the bitumen or at the mixing stage.*

*NOTE 3 Aggregates other than those referred to in a) and b) above may be suitable for asphalt concrete but they are outside the scope of this specification.*

#### **B.2.4.2 Fine aggregate**



#### **B.2.4.2.1 Type of fine aggregate**

The fine aggregate shall substantially pass a 2mm test sieve and be of one of the following types:

finer produced by crushing material from one of the groups specified in **B.2.4.1.1**;

- a) sand; or
- b) a mixture of a) and b).

#### **B.2.4.2.2 Fines content**

The fines content for fine aggregates shall be:

- a) for crushed rock/slag f<sub>NR</sub>;
- b) for sand f<sub>10</sub>.

*NOTE Guidance on fines quality can be found in PD 6682-2.*

#### **B.2.4.3 Added filler**

If added filler is used in dense, close graded, open graded and fine graded mixtures it shall consist of crushed rock, crushed slag, hydrated lime, cement or other material approved by the Highway Authority.

The loose bulk density in kerosene of added filler, with the exception of hydrated lime, shall be in accordance with BS EN 13043:2002, **5.5.5**.

#### **B.2.4.4 Reclaimed asphalt**

Where reclaimed asphalt is to be used in asphalt concrete mixtures the following requirements shall apply.

- a) All reclaimed asphalt shall be classified in accordance with BS EN 13108-8.
- b) The reclaimed asphalt shall conform to the following categories:
  - foreign matter – category F5;
  - binder properties, - category P15.

In accordance with BS EN 13108-8:2016 **5.5.3** as the reclaimed asphalt is for use only at additional percentages of less than 20% in binder courses a sampling frequency of once per 2000t and a single batch of feedstock is specified.

*NOTE 1 P15 is a general case, but reliable and consistent feedstocks of harder reclaimed materials might make them suitable for use, by agreement with the Highway Authority.*

In accordance with BS EN 13108-1:2016, **4.4**, and unless otherwise indicated, the amount of reclaimed asphalt added to the mixture shall not exceed the following.

- surface courses 0%;
- binder course materials 10%

Where, in accordance with BS EN 13108-1:2016, **4.2.2.2** or **4.2.2.3**, the level of reclaimed asphalt addition requires the determination of combined binder properties, the penetration method shall be adopted. For information gathering purposes recovered softening point tests may be conducted on material from the same bulk sample.

## **B.3 Mixture specifications**

### **B.3.1 Binder content**

*NOTE 1 The binder content categories in BS EN 13108 involves a correction for the density of the aggregate in the mix. The principle is that the binder content category in the standard is based on an aggregate density in the mixture of 2,650 Mg/m<sup>3</sup>. If the aggregate is denser than 2,650 Mg/m<sup>3</sup> the actual binder content in the true mixture is reduced proportionally or if the aggregate is less dense it is increased. This has the intention of giving the same binder volume in mixtures regardless of aggregate density.*

*NOTE 2 A consideration of UK mixtures and aggregates indicated that this approach might have been detrimental, as some of the denser aggregates in practice needed higher binder contents for durability. For this reason, the binder contents in the example specifications in this guidance document are those which are required as actual soluble binder contents on analysis of the finished mixture, with no density correction. This is the same as the way in which binder content was specified in BS594 and BS 4987. They are referenced as B<sub>act</sub>.*

*NOTE 3 For the purpose of CE marking, these actual binder contents will need to be corrected back to determine the B<sub>min</sub> defined in BS EN 13108.*

To convert the B<sub>act</sub> target values within PD 6691 back to a B<sub>min</sub> declared value from BS EN 13108, the following formula shall be used:

$$B_{\min} \text{ declared} = \frac{P_b \times B_{\text{act}}}{2,650}$$

Where

P is the mean particle density of the aggregate mixture, in megagrams per cubic metre (Mg/m<sup>3</sup>), determined in accordance with BS EN 1097-6.

The B<sub>min</sub> declared value calculated from this formula shall be in divisions of 0,2. A B<sub>min</sub> declared value of 0,1 division, such as 5,3%, shall be rounded down to the nearest 0,2 value i.e. 5,2%.

**B.3.2 Not used**

**B 3.3 Not used**

**B 3.4.1 to B 3.4.7 Not used**

**B 3.4.8 Recipe dense binder course**

**B 3.4.8.1            General**

**B 3.4.8.2            Aggregate grading and binder content**

*The aggregate grading and binder content at the target composition shall fall within the envelope given in Table B.11. Binder shall conform to BS EN 12591 with the grade as indicated in Clause 9 of this specification.*

**Table B.11**  
**Target limits for composition for recipe dense binder course mixtures**  
**AC 20 Dense bin XX/YY rec**

Mixture Description	20mm dense binder course	
EN nomenclature	AC 20 dense bin	
Test sieve aperture size mm	% by mass passing	
	Targets Limits	Tolerance about target composition A)
40	-	-
31,5	100	-2/+0
20	99-100	-9/+5
10	61-63	±9
6,3 <sup>B)</sup>	47	±9 (Advisory)
2	27-33	±7
0.250	11-15	±5
0,063	6	±3
Aggregate type	Binder content <i>Bact</i>	
Limestone	4.6	±0,6
Basalt	4.7	±0,6
Other crushed rock	4.6	±0,6
Blast furnace slag of bulk density <sub>3</sub> In Mg/m <sup>3</sup> .		
1,44	5,4	±0,6
1,36	5,8	±0,6
1,28	6,2	±0,6
1,20	6,6	±0,6
1,12	7,0	±0,6
Steel Slag	4,2	±0,6
Gravel	5,0	±0,6

*NOTE The specified binder content *Bact* is both minimum and maximum content for categorisation purposes.*

A) These tolerances also apply to site sampled material unless alternative values are agreed in advance with the Highway Authority.

B) The amount passing this sieve shall be reported.

## B 3.5 Recipe Surface Course

### B 3.5.1 Not used

#### B.3.5.2.1 Close graded surface course

The aggregate grading of the target composition shall fall within the envelope given in Table B.14. The binder content of the target composition shall conform to Table B.14.

Binder shall conform to BS EN 12591 grade 100/150 or grade 70/100

Table B.14 Target limits for composition for close graded surface course mixtures AC10 close surf 70/100 or 100/150		
Mixture Description	10mm close graded surface course	
EN nomenclature	AC 10 close surf	
% by mass passing		
Test sieve aperture size mm	Target Limits	Tolerance about the target composition <sup>A)</sup>
14	100	-2/+0
10	100	-8/+5
6,3	62-68	±7
2	25-31	±6
1	14-26	±4
0.063	6,0	±2
Aggregate type	Binder content $B_{act}$	
Limestone	N/A	-
Basalt	5,3	±0,5
Other crushed rock	5,2	±0,5
Blast furnace slag of bulk density In $Mg/m^3$ .		
1,44	6,2	±0,5
1,36	6,6	±0,5
1,28	7,2	±0,5
1,20	7,6	±0,5
1,12	8,2	±0,5
Steel Slag	5,0	±0,5
<p><i>NOTE</i> The specified binder content <math>B_{act}</math> is both minimum and maximum content for categorisation purposes.</p> <p><sup>A)</sup> These tolerances also apply to site sampled material unless alternative values are agreed in advance with the Highway Authority.</p>		

1

**B.3.5.2.2 Close graded surface course, only for use as a temporary footway material.**

The aggregate grading of the target composition shall fall within the envelope given in Table B.14.A

The binder content of the target composition shall conform to Table B.14.A

<b>Table B.14.A</b> <b>Target limits for composition for close graded surface course mixtures</b> <b>AC 14 close surf 100/150</b>		
<b>Mixture Description</b>	<b>14mm close graded surface course</b>	
<b>EN nomenclature</b>	<b>AC 14 close surf</b>	
<b>% by mass passing</b>		
<b>Test sieve aperture size</b> mm	<b>Target Limits</b>	<b>Tolerance about the target composition <sup>A)</sup></b>
20	100	
14	100	-2/+0
10	77-83	-8/+5
6,3	52-56	±7
2	25-31	±6
1 <sup>B</sup>	14-26	±4 (Advisory)
0.063	6,0	±2
<b>Aggregate type</b>	<b>Binder content <i>Bact</i></b>	
Basalt	5,1	±0,5
Other crushed rock	5,1	±0,5
Blast furnace slag of bulk density In Mg/m <sup>3</sup> .		
1,44	5,6	±0,5
1,36	6,0	±0,5
1,28	6,6	±0,5
1,20	7,0	±0,5
1,12	7,6	±0,5
Steel Slag	4,8	±0,5

*NOTE The specified binder content *Bact* is both minimum and maximum content for categorisation purposes.*

A) These tolerances also apply to site sampled material unless alternative values are agreed in advance with the Highway Authority.

B) The amount passing this sieve shall be reported.

### B.3.5.3.1 Dense surface course

The aggregate grading of the target composition shall fall within the envelope given in Table B.15. The binder content of the target composition shall conform to Table B.15.

Binder shall conform to BS EN 12591 grade 70/100 or 100/150.

<b>Table B.15 Target limits for composition for dense graded surface course mixtures AC 6 dense surf 70/100 or 100/150</b>		
<b>Mixture Description</b>	<b>6mm dense surface course</b>	
<b>EN nomenclature</b>	<b>AC 6 dense surf</b>	
	<b>% by mass passing</b>	
<b>Test sieve aperture size mm</b>	<b>Target Limits</b>	<b>Tolerance about the target composition <sup>A)</sup></b>
10	100	-2/+0
6,3	98	-8/+5
2	42-56	±6
1 <sup>c</sup>	24-46	±4 (Advisory)
0,250	11-19	±4
0.063	4-8	±2
<b>Aggregate type</b>	<b>Binder content <i>B<sub>act</sub></i></b>	
Basalt	6,3	±0,5
Other crushed rock	6,2	±0,5
Blast furnace slag of bulk density In Mg/m <sup>3</sup> .		
1,44	6,6	±0,5
1,36	7,0	±0,5
1,28	7,6	±0,5
1,20	8,0	±0,5
1,12	8,4	±0,5
Steel Slag	5,6	±0,5
Gravel	5,4	±0,5

*NOTE The specified binder content *B<sub>act</sub>* is both minimum and maximum content for categorisation purposes.*

A) These tolerances also apply to site sampled material unless alternative values are agreed in advance with the Highway Authority.

B) Higher binder contents may be necessary with some gravel types.

C) The amount passing this sieve shall be reported.

### B 3.5.3.2 Sealing grit

The aggregate grading of the target composition shall fall within the envelope given in Table B.15A. The binder content of the target composition shall conform to Table B.15A.

Binder shall conform to BS EN 12591, grade 160/220 or 250/330.

<b>Table B.15A</b>		
<b>Target limits for composition for sealing grit mixtures AC 4 fine surf 160/220</b>		
<b>Mixture Description</b>	<b>4mm fine graded surface course</b>	
<b>EN nomenclature</b>	<b>AC 4 fine surf</b>	
	<b>% by mass passing</b>	
<b>Test sieve aperture size mm</b>	<b>Target Limits</b>	<b>Tolerance about the target composition <sup>A)</sup></b>
6,3	100	-2/+0
4	98	-8/+5
2	69-87	±6
1	-	-
0,250	18-36	±4
0,063	7-14	±2
<b>Aggregate type</b>	<b>Binder content <i>B<sub>act</sub></i></b>	
Limestone	As nominated by the	±0,5
Basalt	supplier for the given	±0,5
Other crushed rock	aggregate types	±0,5
Blast furnace slag of bulk density In Mg/m <sup>3</sup>		
1,44		±0,5
1,36		±0,5
1,28		±0,5
1,20		±0,5
1,12		±0,5
Steel Slag		±0,5
Gravel		±0,5

*NOTE* The specified binder content *B<sub>act</sub>* is both minimum and maximum content for categorisation purposes.

A) These tolerances also apply to site sampled material unless alternative values are agreed in advance with the Highway Authority.



### B.3.6 Temperature of the mixture

When using paving grade bitumens, the temperature of the mixture at any stage, measured in accordance with BS EN 12697-13, shall not exceed the limits of Table B.17.

**Table B.17 Maximum temperature of the mixture.**

Paving grade of binder	Temperature °C
40/60	190
70/100	180
100/150	170

## 9.13 **ANNEX C**

### **BS EN 13108-4 HOT ROLLED ASPHALT - SPECIFICATION**

Annex C contains the specification which gives the specification for asphalt concrete in accordance with BS EN 13108-4, for use on adoptable highways built in accordance with this specification

#### **Specification for hot rolled asphalt**

#### **C.1 General**

HRA shall conform to BS EN 13108-4. Conformity shall be established in accordance with BS EN 13108-20 and BS EN 13108-21.

#### **C.2 Constituent Materials**

##### **C.2.1 Binder**

The binder shall be paving grade bitumen conforming to BS EN 12591, polymer modified bitumen conforming to BS EN 14023 or a blend of one of these with natural bitumen in accordance with BS EN 13108-4:2006, Annex B.

##### **C.2.2 Not used**

##### **C.2.3 Aggregates**

###### **C.2.3.1 Coarse aggregate**

###### **C.2.3.1.1 Type of coarse aggregate**

The coarse aggregate shall be material substantially retained on a 2mm test sieve, conforming to all appropriate requirements of BS EN 13043 and consisting of one of the following.

- a) Crushed rock of one or more of the following groups, basalt, gabbro, granite,

gritstone, hornfels, limestone, porphyry or quartzite.

- b) Gravel of one or more of the groups in a) or flint, crushed or uncrushed, or combinations of both types.
- c) Blast furnace slag.
- d) Steel slag, either electric arc furnace slag or basic oxygen slag, with a compacted bulk density between 1,60 Mg/m<sup>3</sup> and 1,80 Mg/m<sup>3</sup> when tested in accordance with BS 812-2.

#### **C.2.3.1.2 Particle shape**

The flakiness category for coarse aggregates shall be F135.

#### **C.2.3.1.3 Fines content**

The fines content for coarse aggregates shall be f4.

#### **C.2.3.2 Fine aggregate**

##### **C.2.3.2.1 Type of fine aggregate**

The fine aggregate shall substantially pass a 2mm test sieve and be of one of the following types.

- a) sand;
- b) fines produced by crushing material from one of the groups specified in **C.2.3.1.1**;
- c) a mixture of a) and b).

##### **C.2.3.2.2 Grading**

For surface course mixtures the grading of the fine aggregate shall conform to the appropriate category below:

- a) for Type F surface course mixtures 0/2mm GA90;

##### **Fines content**

The fines content for fine aggregates shall conform to the appropriate fines category below:

- a) for Type F surface course mixtures f10;

*Note Guidance on fines quality can be found in PD 6682-2.*

#### **C.2.3.3 Added Filler**

Added filler shall consist of limestone, hydrated lime, cement or other filler approved by the Highway Authority. The grading of added filler shall be in accordance with BS EN 13043:2002, **5.2.1**.

The loose bulk density in kerosene of added filler, with the exception of hydrated lime, shall be in accordance with BS EN 13043:2002, **5.5.5**.

#### **C.2.3.4 Reclaimed asphalt**

The use of reclaimed asphalt is not permitted in hot rolled asphalt supplied for use on roads constructed in accordance with this specification.

#### **C.2.3.5 Additives**

Additives permitted for inclusion may include fibres, pigments and adhesion agents, the suitability of which shall be demonstrated in accordance with BS EN 13108-4:2016, **4.1**.

#### **C.2.3.6 Coated chippings**

See Clause 9.6 of this specification and C.2.8 of this Annex.

#### **C.2.4 Not used**

#### **C.2.5 Group 2 – Surface course mixtures**

##### **C.2.5.1 Composition, grading and binder content**

###### **C.2.5.1.1 General**

The grading and binder content of the target composition of surface courses shall conform to Table C.2A, Table C.2B or Table C.2C, as appropriate (see **C.2.7**). The requirements for a particular mixture shall be selected in accordance with:

for design surface course mixtures.

*NOTE 1 Type F is characterised by a gap grading typical of traditional HRA surface course mixtures usually associated with the use of a fine sand, although other fine aggregates conforming to the grading may also be suitable.*

###### **C.2.5.1.2 Not Used**

###### **C.2.5.1.3 Design surface course mixtures**

Design surface course mixtures shall be 30/14F from Table C.2A.

The soluble binder content shall not be less than either the greater of the minimum value from Table C.2A or the target binder content determined in accordance with the protocol described in BS 594987:2015, Annex H (see **C.2.7**) and agreed with the Highway and Flood Authority.

**Specification for hot rolled asphalt**

<b>Table C.2A</b> <b>Limits for target composition for surface course mixtures, Type F mixtures- Design target aggregate gradings HRA 30/14 F surf 40/60 des.</b>		
<b>Sieve</b>	<b>Passing sieve % by mass</b>	
	<b>Target Limits</b>	<b>Tolerance about the target composition <sup>A)</sup></b>
20	100	-2/+0
14	93-100	-8/+5
10	67-83	±7
2	65	±5
0,5	49-68	±8 (Advisory)
0,25	19-51	±8
0,063	9,0	±2
<b>Minimum target binder content Bact % (m/m) of total mixture</b>		
	6,5	±0,6
<sup>A)</sup> These tolerances also apply to site sampled material unless alternative values are agreed in advance with the Highway Authority.		
<b>Maximum percentage of aggregate passing 2mm and retained on 0,5mm sieves</b>		
Designation	30/14F	
Maximum percentage	14	

**C.2.6 Temperature of the mixture**

When using paving grade bitumens, the temperature of the mixture at any stage, measured in accordance with BS EN 12697-13, shall not exceed the limits of Table C.4.

<b>Table C.4 Maximum temperature of the mixture</b>	
<b>Paving grade of binder</b>	<b>Temperature °c</b>
40/60	190

When using modified bitumen or additives, different temperatures might be applicable, and these shall be documented and declared as part of the regulatory marking.

**C.2.7 Target binder content**

NOTE 1 The binder content categories in BS EN 13108 involves a correction for the density of the aggregate in the mix. The principle is that the binder content category in the standard is based on an aggregate density in the mixture of 2,650 Mg/m<sup>3</sup>. If the aggregate is denser than 2,650 Mg/m<sup>3</sup> the actual binder content in the true mixture is reduced proportionally or if the aggregate is less dense it is increased. This has the intention of giving the same binder volume in mixtures regardless of aggregate density.

NOTE 2 A consideration of UK mixtures and aggregates indicated that this approach might have been detrimental, as some of the denser aggregates in practice needed higher binder contents for durability. For this reason, the binder contents in the example specifications in this guidance document are those which are required as actual soluble binder contents on analysis of the finished mixture, with no density correction. This is the same as the way in which binder content was specified in BS594 and BS 4987. They are referenced as  $B_{act}$ .

NOTE 3 For the purpose of CE marking, these actual binder contents will need to be corrected back to determine the  $B_{min}$  defined in BS EN 13108.

To convert the  $B_{act}$  target values within PD 6691 back to a  $B_{min}$  declared value from BS EN 13108, the following formula shall be used:

$$B_{min \text{ declared}} = \frac{P_b \times B_{act}}{2,650}$$

Where:

$P_b$  is the mean particle density of the aggregate mixture, in megagrams per cubic metre ( $Mg/m^3$ ), determined in accordance with BS EN 1097-6.

NOTE The mean particle density of the aggregate mixture should be calculated as the weighted mean of the apparent particle densities of the coarse and fine aggregate particle size fractions comprising the mix formulation: 0,063mm to 2mm, 2mm to 4mm, 4mm to 6.3mm, 6.3mm to 10mm, 10mm to 14mm, 14mm to 20mm, 20mm to 31.5mm, 31.5mm to 40mm.

The  $B_{min}$  declared value calculated from this formula shall be in divisions of 0,2. A  $B_{min}$  declared value of 0.1 division, such as 5,3%, shall be rounded to the nearest 0,2 value i.e. 5,2%.

## **C.2.8 Coated chippings for application to surface course**

### **C.2.8.1 General**

For specification purposes coated chippings shall be considered as a mixture and evaluation of conformity determined in accordance with BS EN 13108-20 and BS EN 13108-21.

### **C.2.8.2 Chippings**

Chippings shall be coarse aggregate conforming to **C.2.3**.

The grading of chippings shall be as in Table 9/2 of this specification.

### **C.2.8.3 Binder content**

Binder used to coat the chippings shall be 40/60 grade conforming to BS EN 12591. The target binder content shall be not less than 1,5%.

### **C.2.8.4 Condition of binder coating**

When tested in accordance with BS EN 12697-37, the proportion of retained sand shall be not less than 4,0% for  $D > 16mm$  and 5,0% for  $D < 16mm$ . Not more than 7,5% shall fail the visual assessment.

### **C.2.8.5 Evaluation of conformity**

Evaluation of conformity shall be carried out in accordance with BS EN 13108-4:2006, Clause 6.

### **C.2.8.6 Identification**

Identification should be in accordance with BS EN 13108-4:2016, Clause 7. The delivery ticket shall contain at least the following information relating to identification:

the manufacturer and mixing plant;

the nominal size and source of the aggregate.

## 10. SMALL BLOCK PAVERS, KERBS, CHANNELS AND EDGINGS

---

### 10.1 KERBS, CHANNELS AND EDGINGS (STANDARD)

- 10.1.1 All standard kerbs, channels and edgings irrespective of method of manufacture must comply with BS EN 1340. Unless otherwise agreed in advance in writing, kerbs, channels and concrete edgings shall be manufactured by hydraulic pressure.
- 10.1.2 Kerbs shall be 125mm x 255mm half battered Type HB2 Figure NA1 of BS EN 1340:2003. Channels shall be 125mm x 255mm Type CS1 Figure NA1 of BS EN 1740:2003. Radius kerbs and channels shall be in accordance with BS EN 1340. Dropper or tapered kerbs to accesses shall be 125mm x 255mm reducing 125mm x 150mm Figure NA2 of BS EN 1340:2003 to match as shown on the Domestic Vehicle Crossing diagram Fig 1 / 4. The minimum cut length of a kerb shall be 450mm and a trowel width gap shall be left at the front face of a radius.
- 10.1.3 In certain situations a kerb profile, other than half battered, may be required to conform with adjacent work.
- 10.1.4 Kerbs shall be installed prior to Binder Course being placed, unless the alternative method of working as specified in Clause 1.1.17 is employed, which will require the binder course to be laid in two separate stages and be increased in overall thickness as specified.**
- 10.1.5 Kerbs, channels and edgings shall be laid and bedded on a 30mm layer of cement mortar. Wet bedding of kerbs in the bedding concrete is not permitted.
- 10.1.6 Radius kerbs or radius channels shall be used in curves where the radius is 15 metres or less. For radii between 15m and 80m inclusive, straight kerbs of length 600mm must be used, unless channels are required in which case radius kerbs and channels will be required. For radii greater than 80m and all straights, kerbs 600mm or 900mm length shall be used.
- 10.1.7 Channels shall be laid to the same crossfall as the adjoining carriageway. Any unit found to be more than 3mm out of line or level at either end shall be lifted and relaid, including any necessary breaking out and replacement of the concrete foundation and backing.
- 10.1.8 Concrete bedding and concrete haunching for kerbs, channels and edgings shall be constructed to the dimensions shown on the Drawings and shall consist of ST4 (15N/mm<sup>2</sup>) concrete low workability as specified in Clause 12.1.
- 10.1.9 Within the catchment of traditional drainage design, channel blocks are required where the longitudinal gradient of the carriageway falls below 1 in 150. Where the gradient falls below 1 in 250 the carriageway shall be laid flat and channel blocks laid to false falls.

### 10.2 SMALL BLOCK PAVERS: CONCRETE BLOCK PAVING

- 10.2.1 Pre-cast concrete paving blocks shall be chamfered and shall comply with BS EN 1338 and conform to the shapes, dimensions and colours described on the drawings approved by the Highway and Flood Authority. Only rectangular shaped blocks will be permitted. Blocks shall have a minimum Polished Paver Value (PPV) of 55. Pre-cast paving blocks shall be laid in accordance with BS7533 Part 3 except as detailed in Clause 1.6(c). The layout of blocks, their colour and details at edges, manholes, gullies and other openings shall be as recommended by the supplier and agreed with the Highway and Flood Authority in advance of construction commencing.

### **10.3 SMALL BLOCK PAVERS: CLAY PAVERS**

- 10.3.1 Clay Pavers shall comply with BS EN 1344 and shall have chamfers. The shape and dimensions of Clay Pavers shall be in accordance with the Specification requirements and as described on the agreed drawings. Only rectangular shaped pavers will be permitted. Blocks shall have a minimum Polished Paver Value (PPV) of 55.
- 10.3.2 Clay Pavers shall be laid in accordance with BS7533 Part 3 except as detailed in Clause 10.4. The layout of pavers, their colour and details of edges, manholes, gullies and other openings shall be as recommended by the supplier and agreed with the Highway Authority in advance of construction commencing.
- 10.3.3 For carriageways constructed in accordance with Chart 3, pavers with a minimum thickness of 60mm shall be used.
- 10.3.4 For carriageways constructed in accordance with Chart 6, pavers with a minimum thickness of 80mm shall be used.
- 10.3.5 Additionally, pavers incorporated in Chart 6 carriageways shall be specifically designed for pervious pavements.
- 10.3.6 Transition details to be as per Figure 2/2 when changing from block paving to traditional bituminous construction.

### **10.4 SMALL BLOCK PAVERS: LAYING COURSE**

- 10.4.1 Laying course material (bedding sand) for small block pavers made either from pre-cast concrete or clay shall comply with BS 7533-3:2005+A1:2009 and the following requirements:-
- 10.4.2 The aggregate shall be naturally occurring or crushed glass, be washed and conform as follows:-
- 10.4.3 For roads constructed in accordance with Construction Chart 3 the properties of the laying course shall comply with Table D.3, category II of BS7533-3
- 10.4.4 For roads constructed in accordance with Construction Chart 6, the laying course, jointing material and binder course drainage hole fill shall comply with Table 10/1 and 10/2
- 10.4.5 The laying course for small unit pavers in footways shall conform with the grading requirements of Table D.3, category III of BS7533-3
- 10.4.6 Crushed rock laying courses shall be used for Construction Chart 6 roads.
- 10.4.7 Except for construction Chart 6 roads jointing material shall comply with the requirements of Table D.4 of BS7533-3



10.5

**Table 10/1: Requirements for Aggregates Used as Laying Course, Fill for Binder Course Cored Drainage Holes and Jointing Materials Chart 6 Roads.**

Properties	Category to BS EN 13242 or BS 12620	
	Laying Course Drainage Hole Fill and Jointing Material	Alternative Jointing Material
Grading	G <sub>c</sub> 80/20 2/6,3	G <sub>c</sub> 80/20 2/4
Fines Content	F <sub>2</sub>	
Shape	FI <sub>35</sub>	
Resistance to fragmentation	LA <sub>30</sub>	
Durability: Water absorption to BS EN 1097 – 6:2000 + A1:2005, Clause 7 – for WA > 2% Magnesium sulphate soundness	WA <sub>242</sub>  MS <sub>18</sub>	
Resistance to wear	M <sub>DE</sub> 20	
Acid-soluble sulphate content:	AS <sub>0.2</sub>	
Total sulphur:	≤1% by mass	

**Table 10/2: Grading Requirement for Laying Course, Drainage Hole Fill and Jointing Materials for Pervious Pavements for Chart 6 Roads.**

(BS EN 12620: G<sub>c</sub> 80/20 2/6,3 or G<sub>c</sub> 80/20 4/2 coarse aggregate)

Sieve size (mm)	Percentage by mass passing (%)	
	Laying Course Drainage Hole Fill and Jointing Material	Alternative Jointing Material
14	100	
10	98-100	
8	-	100
6.3	80-99	98-100
4	-	80-99
2	0-20	0-20
1	0-5	0-5
0.063	0-2 (BS EN 12620: fines category f <sub>2</sub> )	

**Jointing and void filling material for Construction Chart 6 Roads.**

Jointing and void filling material for Construction Chart 6 roads, shall comply with Tables 10/1 and 10/2 unless the paving unit manufacturer advises otherwise and any alternatives are agreed in advance of use with the Highways and Flood Authority.

## 11. CULVERTS, RETAINING WALLS AND OTHER STRUCTURES

---

### 11.1 GENERAL

11.1.1 For the purposes of technical approval and future maintenance, highway 'Structures' are defined as:

- any bridge, box culvert, pipe (regardless of shape), arch, span, deck, cantilever, foot bridge or similar of width 600mm or higher.
- any retaining wall, headwall, wing-wall, gabion wall, training wall, reinforced embankment, piled wall, or similar with a retained fill height of 600mm or higher.

All structures meeting these criteria will require the Design Approval of TSP Structures Team.

All pipework below 600mm diameter is classified as drainage pipes (see Clause 5).

11.1.2 These structures are further delineated as below:

11.1.3 Culverts (and some smaller bridges) are primarily provided to convey water (via drains, ditches and dykes) from one side of a road to the other. They are usually located between open watercourses, either parallel or perpendicular to the road. These structures are maintained by TSP Structure Team once adopted.

11.1.4 Drainage pipes are usually provided as an underground conduit to collect and transfer run-off from the carriageway to a suitable outfall.

11.1.5 Storm water storage structures are primarily provided for attenuation of carriageway run-off. These are generally located between road gullies and carrier drains upstream and a hydro-brake to slow the flow downstream

11.1.6 Any retaining wall, headwall, wing-wall, gabion wall, training wall, reinforced embankment, piled wall, or similar attached to a bridge, culvert drainage pipe or storm water system is considered an integral part of the associated structure and maintained as part of the associated structure.

### 11.2 OWNERSHIP AND LAND REQUIREMENTS

11.2.1 All highway structures must be located wholly within the limits of the adopted public highway. The highway authority will only adopt the structure in entirety, which will include the headwalls, wing-walls, parapets and the like for any piped culvert or drain.

11.2.2 Only structures maintained in perpetuity by other statutory bodies (for example Network Rail or drainage authorities) will be permitted to remain in private ownership within the public highway following construction. In such instances, the design of these structures will be approved by TSP Structures Team with

regard to strength and capacity only, but not durability.

- 11.2.3 The adoption of any road (carriageway / footway etc.) beyond, or supported by, any private structure which relies exclusively on the private structure for access will not be sanctioned under any circumstances.
- 11.2.4 The Highway Authority requires a minimum distance of 3m horizontally beyond the extents of all structures to be available to facilitate the future maintenance and eventual replacement of the structure. This may be achieved through either land dedication or granting of an easement over adjacent land.
- 11.2.5 If any structure provides the only means of access into either residential or commercial properties, consideration must be given to maintaining access into these properties during any future maintenance and the eventual replacement of the structure.
- 11.2.6 This may be achieved by widening the structure sufficiently to facilitate the replacement in part whilst maintaining a single lane for vehicles during the works. Alternatively, a temporary access for vehicles during replacement may be provided – however this temporary access route will require legal protection in perpetuity.
- 11.2.7 Access to any properties, either residential or commercial, during any future structure replacement must be maintained all at times for both cars and HGV's to allow for access by all emergency vehicles.
- 11.2.8 The requirements contained within the current version of *Safety at Street Works and Road Works, A Code of Practice* (or its equivalent replacement) must be used when assessing the necessary widths for traffic lanes, safety zones and the like when considering the works required for the replacement of any structure.
- 11.2.9 Retaining walls located on the edge of the public highway generally reside in the ownership of the party gaining the benefit from the presence of the wall, and any land dedication must be unambiguous in demonstrating this. Any private retaining walls located at the edge of the public highway (or if the failure of such a wall could adversely affect the integrity of the public highway), require the design approval of TSP Structures Team, with regard to their strength and capacity. The loading requirements for any retaining walls supporting retained ground above the public highway must be agreed with TSP Structures Team.
- 11.2.10 Only in exceptional circumstances are highway culverts permitted to be directly connected to private drainage systems maintained by other bodies or individuals. This will require the explicit consent of TSP structures team, once all other alternative solutions can be shown to have been exhausted.
- 11.2.11 Any private retaining wall structures close to the public highway will require the approval of TSP structures team should they fall within the constraints shown in figure 11/1.

### 11.3 DESIGN AND TECHNICAL APPROVAL REQUIREMENTS

- 11.3.1 Structures are to be designed and drawn by suitably qualified civil engineers with a working knowledge and experience of the design of highway structures to current standards as referred to in Clause 11.3.3 below.
- 11.3.2 A Lincolnshire County Council (LCC) document entitled "*Small Highway Structures Design Guide*" (*shsDG*) gives more detailed guidance and is available on request from the Highway and Flood Authority.
- 11.3.3 The design of all structures must comply with requirement of the Highways England "*Design Manual for Roads and Bridges*" (*DMRB*) as enacted and supplemented by the LCC *shsDG* document. As an alternative to any withdrawn British Standards listed in the *DMRB*, designs will be accepted complying with the bridges parts of the relevant Eurocodes including the UK National Annexes. The use of any Highways England "*Interim Advice Notes*" (*IAN's*) modifying the *DMRB* should be confirmed with TSP Structures Team beforehand.
- 11.3.4 **Design Approval** must be obtained from TSP Structures Team for all structures either adopted as public highway or close to the public highway as defined by the scope above, prior to the commencement of their construction. A general list of documents required for the approval submission is provided on the "*Structures Design Submission Requirements*" checklist appearing in Appendix 3.
- 11.3.5 As part of this Design Approval process, it will be necessary to gain **Technical Approval** in accordance with the requirements of *BD2 (DMRB: Volume 1, Section 1, Part 1)*. This Technical Approval may necessitate the submission for endorsement of an "**Approval in Principle**" (*AiP*) document for the structure before the commencement of detailed design.
- 11.3.6 If the design does not fully comply with the requirements of the *DMRB*, any deviation will be subject to the *Departure from Standards (DfS)* procedure detailed elsewhere. It should be noted that any *DfS* will classify the structure as CAT2 under *BD2* requirements, necessitating the submission of an *AiP* document. Note, omission of safety barriers from the approach or departure of a vehicle parapet constitutes a *DfS*.
- 11.3.7 In the case of works to be carried out in or adjacent to any watercourse, the design must also be submitted to any affected drainage authority for approval. Generally for culverts and bridges the invert level and waterway area will be specified by the appropriate drainage authority. The Highway and Flood Authority will require proof that this Flood Defence Consent has been issued before Technical Approval can be granted.
- 11.3.8 It is strongly recommended that a General Arrangement drawing be submitted to the Highway and Flood Authority for comment at an early stage in the design process to minimize the risk of abortive work.
- 11.3.9 Consideration must be given to the risk of potential blockages of culverts, bridges and the like by debris in the watercourse. To minimize this risk,

culverts must be a smooth bore to allow any debris to pass through the structure. The connection of lateral drains or construction of manholes or catch-pits on any culvert must be avoided unless absolutely necessary. Generally a separate highway drainage system should be provided, independent of the culvert structure.

If a smooth bore cannot be provided to any culvert, it is imperative that suitable debris grills are provided to reduce the risk of any potential blockage of the culvert. A grill must be provided at both ends of the culvert, to avoid any risk of blockage should the watercourse back-up downstream from another obstruction. If debris grills are necessary the required commuted sum for the structure will be increased to include both the additional costs of inspection due to the presence of the grills and the routine inspection and removal of debris against the grill. This work will be required frequently, and the increase in the commuted sum should be expected to be a substantial amount.

#### **11.4 BURIED SERVICES**

11.4.1 All buried services must be contained in suitable ducts where these pass over, under, through or adjacent to a structure. The ducts must extend sufficiently far to facilitate the replacement of the structure without undue disturbance to the buried services. The attachment of exposed services or ducting to any structure façade(s) will not be permitted.

11.4.2 Directional drilling to install new services will require the explicit approval of the TSP Structures Team and will not be permitted within 3m of any structure. Generally any new services should be installed 3m clear horizontally from any structure, if this is impractical services may be installed below a structure only if; the foundations of the structure are certain, and a minimum 3m vertical clearance is provided between the new service and lowest point of the foundations of the structure.

11.4.3 Provision for future buried services must be accommodated in all structures, regardless of their location or further development expectations. This provision must be in the manner of spare ducts in appropriate sizes, that allow services to cross (or pass by) the structure without the need to break the highway surface and potentially damage any buried elements of the structure.

11.4.4 Drainage systems adopted by other authorities must not be incorporated into highway structures in any manner, including the inclusion of outfalls and the like into structure headwalls or wing-walls.

#### **11.5 CONFINED SPACES**

11.5.1 The difficulties of inspecting and maintaining small structures must not be underestimated, either for undertaking routine inspections, cleaning of silt and debris from structures or carrying out routine repairs to structural elements.

11.5.2 Consideration must be given to providing appropriate facilities to reduce the potential risks to any operatives required to undertake the inspection and maintenance of structures to be as low as reasonably practicable.

11.5.3 The increased difficulty and associated costs in carrying out such inspections

and maintenance in any confined spaces (for example, the need for operatives to be provided with breathing apparatus) will be directly reflected in the increased commuted sum payable in respect of the adoption of the structure.

## **11.6 SPECIFICATION**

- 11.6.1 The execution specification for the construction on site shall be the current Highways England "*Specification for Highway Works*" (*SHW's*), applied in accordance with the notes for guidance on that Specification and incorporating all subsequent amendments.
- 11.6.2 Reference to the *SHW's* must be clearly made on the contract drawings, and no conflicting references to other specifications (e.g. water authorities) will be permitted to avoid dispute.
- 11.6.3 Any LCC specific amendments to the *SHW's* are detailed in the "*Small Highway Structures Design Guide*" (*shsDG*) document, referred to above. For the avoidance of doubt during the execution of the works, any of these LCC amendments to the *SHW's* appropriate to the works undertaken must be reproduced on the contract drawings.

## **11.7 DESIGN CERTIFICATION**

- 11.7.1 All highway structures require design certification in accordance with *BD2*.
- 11.7.2 The certification required is dependent upon the complexity of the structure; the requirements are specific to the categorization of the structure as defined by *BD2*. Model certificates are included in Annex C to *BD2*.
- 11.7.3 The latest version of the "*Technical Approval Schedule*" (*TAS*) is available at <http://www.standardsforhighways.co.uk/ha/standards/dmr/vol1/section1/GenericTAS.doc> this document must be used as part of the design certification process to indicate the relevant standards used in the design of the structure. Any standards inapplicable to the design should be struck through on the *TAS*, and the design must be fully compliant with the remaining standards. All departures from the remaining standards must be clearly identified in the *AiP* document.
- 11.7.4 Endorsement by the Technical Approval Authority (TAA) of the Design Certificate is the final stage of the Design Approval process. This certificate will only be passed to the TAA by TSP Structures Team once all matters relating to the design are successfully resolved to their satisfaction. Additional design queries requiring resolution may be raised by the TAA prior to endorsement. Once the certification is endorsed by the TAA, the design is formally approved by LCC for construction.

## **11.8 INSPECTION DURING CONSTRUCTION**

- 11.8.1 Representatives of the TSP Structures Team will inspect and test all adoptable highway structures that are subsequently maintained by this team during construction on site.
- 11.8.2 The TSP Structures Team may also wish to verify the construction of private

structures with the potential to affect the strength or integrity of the public highway as discussed above.

11.8.3 Any alterations required on site to the approved design must be submitted to TSP Structures Team for written approval of the change, in accordance with the principles detailed above.

11.8.4 The inspection requirements for structural works are generally demonstrated on the "*INSPECTION REQUIREMENTS FOR STRUCTURAL WORKS*" table. TSP Structures Team will confirm the specific requirements for each structure prior to construction. Note that individual structures may not have all the elements listed in the table; however certain elements may require multiple inspections.

11.8.5 The requirements detailed consist of:

(i) Mandatory testing to be undertaken by contractor

The relevant test must be carried out by an independent appropriate accredited body, and results must be supplied to TSP Structures Team for consideration as soon as available. TSP Structures Team will confirm acceptability or otherwise of the test and result. Note, only concrete strengths tested on 28 day cubes will be accepted.

(ii) Approval of process / material source

This approval will be granted in writing by TSP Structures Team, details must be submitted a minimum of 3 clear working days in advance of the associated operation commencing.

(iii) Notice of activity commencement

A minimum of 2 clear working days' notice must be given to TSP Structures Team to allow the opportunity to organise visits to the site for staff to be present during these operations.

If the operation does not proceed or is not completed satisfactorily on the date advised, a further 2 clear working days' notice will be required for an additional visit.

(iv) Inspection on activity completion

A minimum of 2 clear working days' notice must be given to TSP Structures Team to allow the opportunity to organise visits to the site for staff to inspect these items before subsequent operations.

If the item requested for inspection is not completed or is unacceptable standard on the date advised, a further 2 clear working days' notice will be required for a subsequent inspection.

(v) Certification on completion

A key stage certificate generally in accordance with "*KEY STAGE X1 – STRUCTURES*" will be endorsed by the TSP Structures Team on completion of

each element. All items identified must be endorsed before the structure deemed to be complete. This will be further endorsed to signify the structure is suitable to be placed on maintenance and suitable for adoption.

- 11.8.6 Any failure to notify TSP Structures Team of the appropriate inspection requirements may affect the suitability of the final structure for adoption, including any road beyond which relies exclusively on the structure for access.
- 11.8.7 Any failure to notify TSP Structures Team of the appropriate inspection requirements may result in an increased commuted sum being required due to the uncertainty of the potentially reduced long term durability of the completed structure.
- 11.8.8 For the avoidance of doubt, contemporary records (photos, measurements etc.) will not be accepted as proof of quality of construction in the absence of notification of inspection requirements, unless agreed with TSP Structures Team before notification of the appropriate inspection was due.

## **11.9 AS-BUILT INFORMATION REQUIREMENTS FOR STRUCTURES**

- 11.9.1 On completion of each individual structure, and prior to adoption, a *Health and Safety File* relating only to the structure must be provided to TSP Structures team in accordance with the requirements of the *The Construction (Design and Management) Regulations 2015*.
- 11.9.2 The provision of a generic *Health and Safety File* relating to the whole of the site will not be accepted.
- 11.9.3 The method of submission of the *Health and Safety File* must be agreed with TSP Structures, including the file type and format for any electronic information.
- 11.9.4 The *Health and Safety File* must include as a minimum the following information:
  - As-built drawings – Generally these are based on the approved construction drawings, and clearly marked up as such. Any alterations from the approved drawings must be included on these drawings. Nonspecific specification requirements must be replaced with specific product details, including suppliers.
  - All pertinent manufacturer information relating to products used in the structure, including where appropriate the recommended inspection and maintenance requirements for the product.
  - Test results and certificates for all mandatory testing undertaken.
  - Information on any residual risks or hazards remaining following adoption of the structure, specifically including information regarding the future access arrangements for the inspection and maintenance of the structure.



- A fully completed *INVENTORY INPUT INFORMATION FORM* for each structure.
- Clear land plans at an appropriate scale showing the structure and; land dedication, ownership, adopted areas, and specifically any easements granted for the future maintenance or reconstruction of the structure.

#### **11.10 CONSTRUCTION OF RETAINING WALLS OUTSIDE OF THE HIGHWAY**

11.10.1 The *Highways Act 1980, Section 167 - Powers relating to retaining walls near streets* relates to the construction of private retaining walls outside of the public highway, and the necessity for the highway authority Design Approval of these walls.

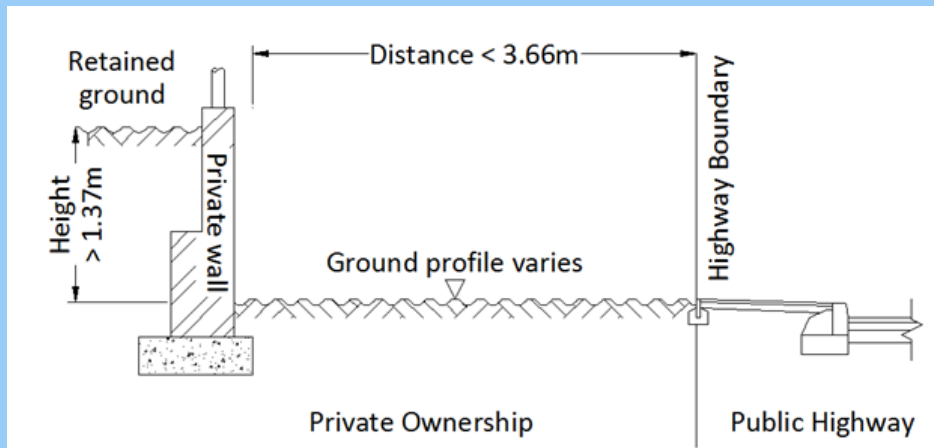
11.10.2 In this section “retaining wall” means a wall, not forming part of a permanent building, which serves, or is intended to serve, as a support for earth or other material on one side only.

11.10.3 Any length of a retaining wall, which any part of the cross-section is within 3.66m (4 yards) of the public highway; and which is at any point of a greater height than 1.37m (4 feet 6 inches) above the level of the ground at the boundary of the street nearest that point; shall be erected in accordance with plans, sections and specifications approved by the highway authority.

11.10.4 If a length of private retaining wall to which this section applies is in such condition (whether for want of repair or some other reason) as to be liable to endanger persons using the street, the highway authority will, by notice served on the owner or occupier of the land on which that length of wall is, require him to execute such works as will obviate the danger.

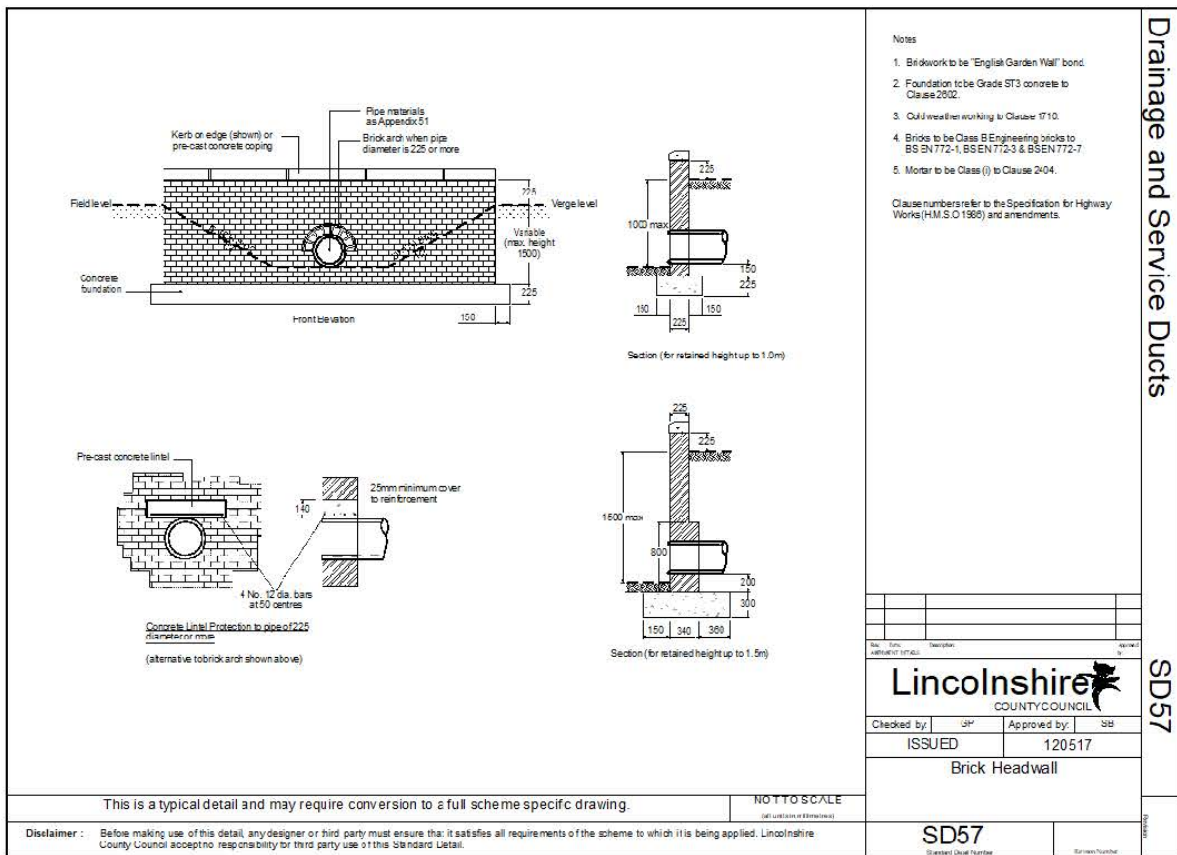
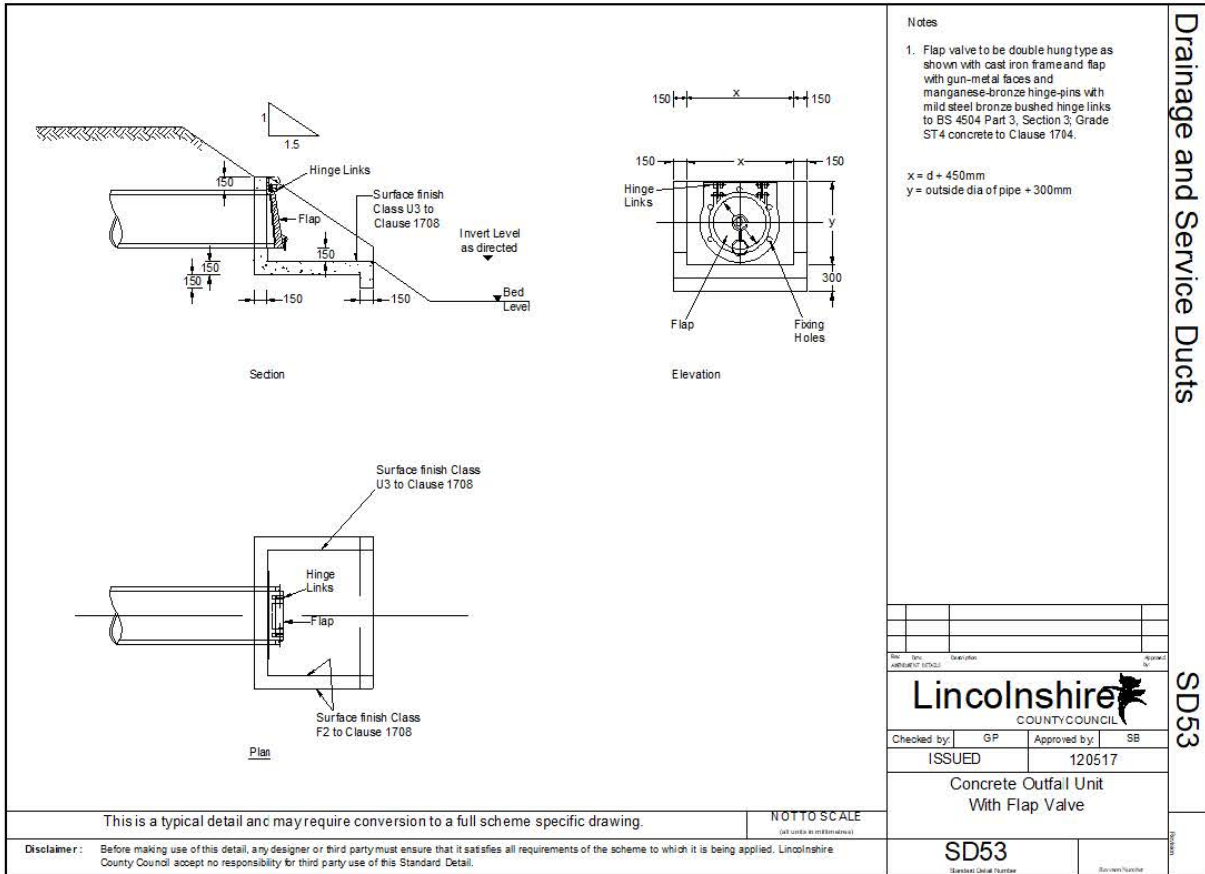
11.10.5 The Design Approval check will be undertaken by the TSP Structures Team. This check will only consider the strength and capacity of the wall.

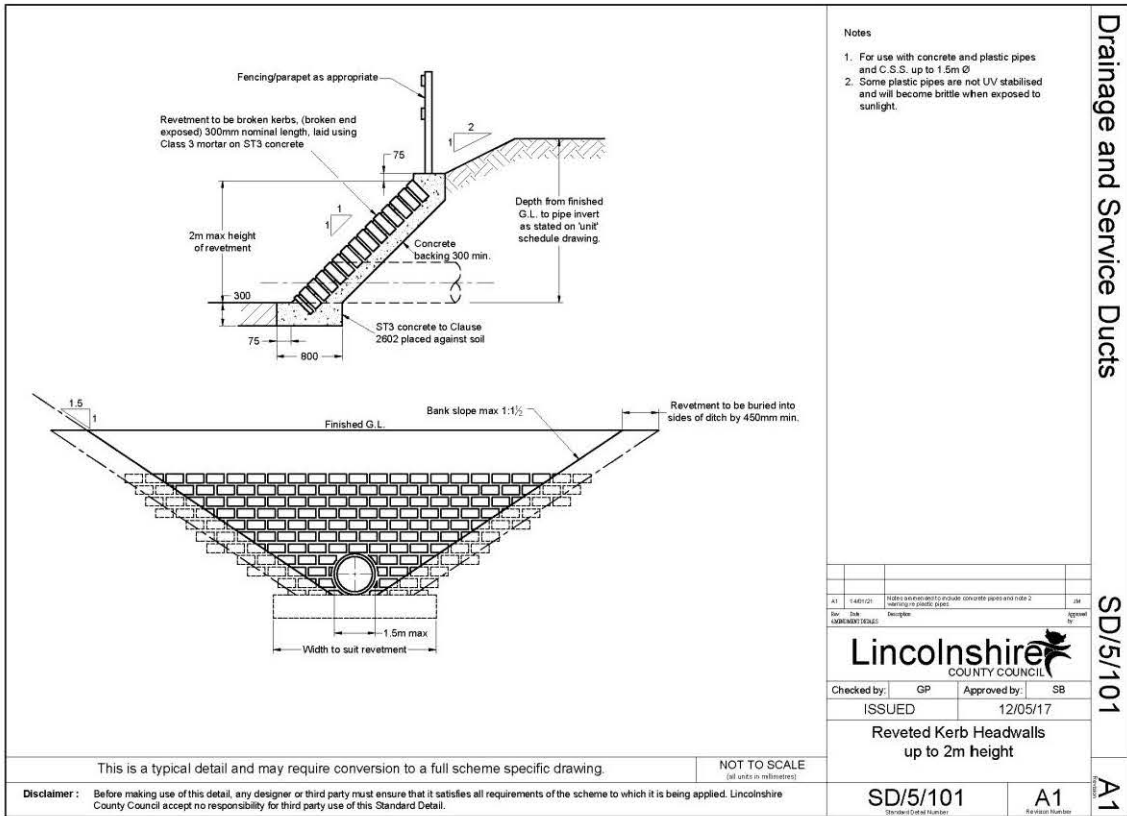
**FIGURE 11/1 – CROSS SECTION SHOWING CRITERIA FOR APPROVAL OF NON-ADOPTABLE RETAINING WALLS**



**Notes :-**

- 1) Both criteria (distance and height) are to be satisfied for design approval to be necessary**
- 2) Distance is measured to the closest point of the wall or foundation**
- 3) Height is measured from the edge of the highway to the retained height**

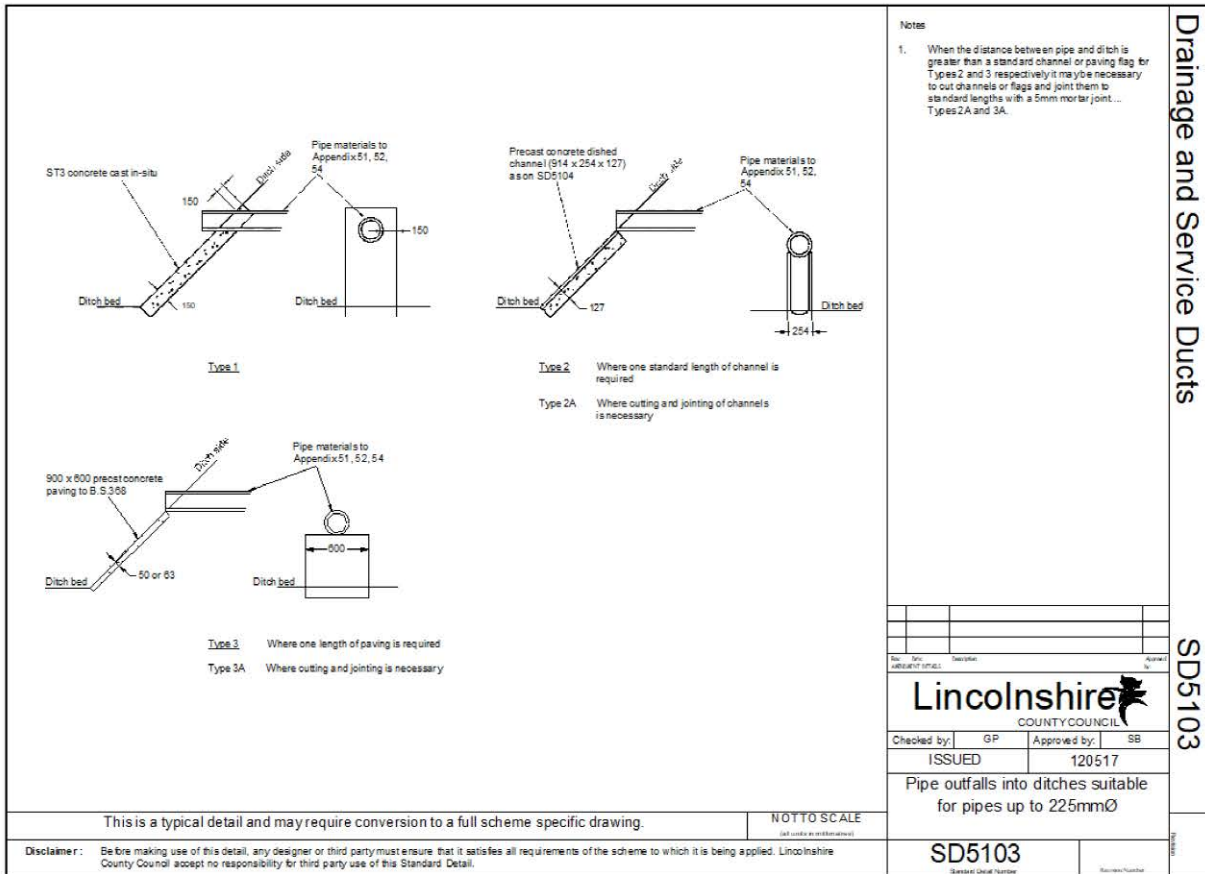




Drainage and Service Ducts

SD/5/101

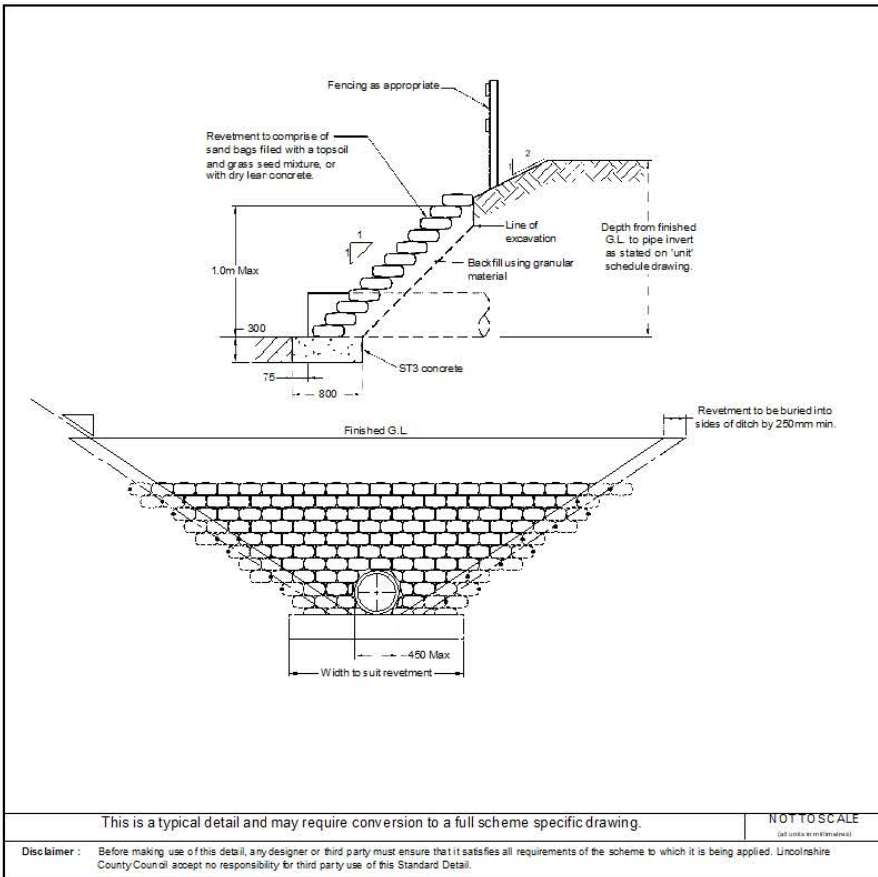
A1



Drainage and Service Ducts

SD5103

A1



Notes

1. Max pipe diameter 450mm

Rev	14/11/21	SD5107 (Rev 4.3) on which to match notes	GP
App	15/11/21	Approved	SB

**Lincolnshire**  
COUNTY COUNCIL

Checked by	GP	Approved by	SB
ISSUED		120517	

Reveted Bagwork Headwalls  
for up to 525mm pipe diameter

SD5107	A1
<small>Standard Detail Number</small>	<small>Revetment Number</small>

This is a typical detail and may require conversion to a full scheme specific drawing.

NOT TO SCALE  
(All units in millimetres)

**Disclaimer:** Before making use of this detail, any designer or third party must ensure that it satisfies all requirements of the scheme to which it is being applied. Lincolnshire County Council accept no responsibility for third party use of this Standard Detail.

## 12. CONCRETE

### 12.1 CONCRETE MIXES

12.1.1 Concrete shall be ready mixed concrete complying with Clause 4.5 BS 8500-1: 2006 and BS EN 206-1:2000. The maximum aggregate size shall be 20mm. Suppliers shall be members of QSRMC and have a quality management system complying with the requirements of BS EN ISO 9001: 2000.

12.1.2 The following table gives details of Standard Prescribed concrete mixes and their related strengths.

**Table 12/1**

Standardized prescribed concrete	Strength class that may be assumed for structural design (Note 1)	Characteristic compressive cube strength at 28 days that may be assumed for structural design (N/mm <sup>2</sup> )
ST1	C6/8	8
ST2	C8/10	10
ST3	C12/15	15
ST4	C16/20	20
ST5	C20/25	25

12.1.3 Standard mixes shall not be used where:-

- Sulphates or other aggressive chemicals are present in the ground water.
- Where concrete will be subjected to road de-icing salt without addition of an air entraining agent.

In these circumstances prior consultation with the Highway Authority shall be undertaken for the selection of a suitable mix.

Admixtures and cement containing additives shall not be used without specific approval, in writing, from the Highway and Flood Authority.

Circumstances will occur when small quantities of concrete are required where the use of ready mix concrete would be prohibitively expensive. Site batched concrete will only be permitted in unreinforced applications.

For Mix details refer to the following table:-

**Table 12/2**

Compressive Strength (N/mm <sup>2</sup> ) (Note 1)	Mix proportions by volume		
	Coarse	Fine	Cement
C12/15	4	2½	1
C16/20	4	2	1
C25/30	3	1½	1

The quantity of water used shall not exceed that required to produce a dense concrete with sufficient workability to enable it to be placed and compacted where required.

Note 1 Concrete compressive strengths are defined in terms of both cylinder strength and cube strengths. The first (lower) number gives the cylinder strength requirement; the second (higher) number is the cube strength requirement.

## **12.2 COLD WEATHER WORKING**

- 12.2.1 No material below 3C or material containing frost or ice shall be used, and mixing shall not be carried out when the still air temperature in the shade is below 3C.
- 12.2.2 Concrete shall not be placed against any shutter, reinforcement, previously placed concrete or foundation which has a surface temperature below 3C.
- 12.2.3 Precautions shall be taken to ensure that the temperature of the concrete is maintained above 4C until it has hardened.

## **12.3 TRANSPORT AND PLACING**

- 12.3.1 Concrete shall be so transported and placed that segregation or loss of the constituent materials does not occur.
- 12.3.2 All concrete shall be compacted in its final position within 30 minutes of being discharged from the mixer unless carried in continuously operated purpose-made agitators, when the time shall not be more than 2 hours after the introduction of the cement to the mix and within 30 minutes of discharge from the agitator. If the temperature of the cement entering the mixer exceeds 65°C the concrete shall be placed within 15 minutes of discharge from the mixer. Cement exceeding 75°C shall not be used in the manufacture of concrete. Concrete when deposited shall have a temperature of not less than 5°C and not more than 32°C.
- 12.3.3 Spaces to be occupied by concrete shall be clean and free from standing water. Concrete shall not be dropped from a height greater than 2 metres. When chutes are used they shall have a slope greater than 50° to the horizontal and they shall be kept free from coatings of hardened concrete or other obstructions.
- 12.3.4 Fresh concrete shall not be placed against concrete which has been in position for more than 30 minutes unless an approved construction joint is formed.

## **12.4 COMPACTION OF CONCRETE**

- 12.4.1 All concrete shall be compacted to produce a dense homogeneous mass. It shall be compacted with the assistance of vibrators, care being taken to avoid contact with reinforcement and inserts. Placement and compaction shall be completed within 2 hours after introduction of the cement to the mix. Once compaction is complete and 2 hours has elapsed since introduction of cement to the mix, no further concrete shall be placed adjacent to the mix until 24 hours has passed since cement was added to the initial mix.

## **12.5 CURING OF CONCRETE**

- 12.5.1 Immediately after completion and for 7 days thereafter, concrete shall be protected against harmful effects of weather, including rain, rapid temperature changes, frost and from drying out.

## **13. BRICKWORK**

---

### **13.1 BRICKWORK: GENERAL**

13.1.1 Details of brickwork for sewerage and drainage purposes are given in Section 5.8. Brickwork for other purposes to be adopted by the Highway and Flood Authority shall comply with this Clause.

### **13.2 EXPOSED JOINTS**

Exposed joints shall be treated in the following ways:-

#### **13.2.1 Pointed Joints**

Joints in brickwork shall be raked out for a depth of 14mm and pointed in mortar. Unless otherwise required by the Highway and Flood Authority joints treated in this manner shall be flush pointed.

#### **13.2.2 Unpointed Joints**

- i. The mortar for joints in brickwork which are not to be pointed shall extend slightly beyond the full width of the beds and shall then be struck off with the trowel as the work proceeds.
- ii. No overhand work will be allowed. Any putlog holes must be filled in with bricks identical with those already incorporated in the facework. Every third course shall be laid fair and correct to the line and all perpends shall be accurately kept.
- iii. In building brickwork above concrete or stonework already completed the Developer shall also take the necessary precautions to prevent any mortar or debris from falling into the open expansion joints.

### **13.3 COLD WEATHER WORKING**

13.3.1 No bricks or other materials below 3°C or containing frost or ice shall be used. Mortar mixing and laying bricks shall not be carried out when the still air temperature in the shade is below 3°C.

13.3.2 Bricks shall not be laid on previously laid brickwork or foundation which has a surface temperature below 3°C.

13.3.3 Precautions shall be taken to ensure that the temperature of the brickwork is maintained above 4°C until the mortar has hardened.

### **13.4 FACING BRICKWORK**

13.4.1 The requirements for solid brickwork shall apply to facing brickwork except that the joints shall be as required by the Highway and Flood Authority. All facing brickwork shall be well bonded to the backing bricks or concrete and anchor ties of approved manufacture shall be provided where required by the Highway and Flood Authority. No facing brickwork shall be brought up at any time for more than 600mm in advance of the backing.



## 14. STREET LIGHTING

---

### 14.1 APPROVAL

- 14.1.1 Before construction commences Developers shall submit their proposals for street lighting, to the Highway and Flood Authority for approval. The lighting system (including the design and components) shall be in accordance with the requirements of “Annex 3 Lincolnshire County Council Street Lighting Design Guide” which is available on request from the Highway and Flood Authority.
- 14.1.2 The developer must arrange for a street lighting design to be undertaken by a competent lighting designer in accordance with the requirements of the LCC Street Lighting Design Guide.
- (i) LCC's Street Lighting Department can provide a lighting design service. Developers shall email a plan of the proposed development layout to [Streetlighting@lincolnshire.gov.uk](mailto:Streetlighting@lincolnshire.gov.uk) and a quotation for this service will be provided based on the development's requirements.
  - (ii) Alternatively the Developer can arrange for the street lighting design to be undertaken independently. Please email a plan of the proposed development layout to [Streetlighting@lincolnshire.gov.uk](mailto:Streetlighting@lincolnshire.gov.uk) and a site specific brief will be issued by the LCC Street Lighting Department.
- 14.1.3 The developer's detailed design submission should include:-
- (i) A S38 General Layout drawing including the layout of proposed street lighting, including illuminated signs (if appropriate) and details of any adjoining existing lighting apparatus which may be affected by the Developer's proposals. The drawing is to include street lighting equipment specification details and appropriate notes, and shall be to a scale not less than 1:500.
  - (ii) Lighting Design Calculations. These should be derived from Lighting Reality with file names that clearly describe the location and should include:
    - 'User notes/title page notes' – these should describe the target lighting class including a commentary on the design constraints and explain any deviations from design standards.
    - 'Roadway' calculations – are required to demonstrate compliance, determine optimal spacing & the optimal optic choice for the site's predominant road geometries. The original RTMR files are required.
    - 'Outdoor' calculations – are also required for illuminance of irregular areas; multiple calculation grids should be provided, with grids confined to relevant discrete areas to minimise any distorting effects on average illuminance values. The original RTMA files are required.
    - PDF Lighting Reports & 'read-only' files - should exclude greyscale, points and unnecessary isolux contour lines. Masks should not be hidden and the results should be displayed.

- 14.1.4 If the initial street lighting design submission is not acceptable, the Developer will need to incorporate LCC's comments from the design appraisal into revisions as required and resubmit proposals for further scrutiny as necessary.
- 14.1.5 If the proposed highway features are altered at any stage prior to or during construction, then lighting column positions may need to be reconsidered by the designer. The Developer must supply revised design calculations and drawings.

**NOTE:** If the Developer has used the LCC Street Lighting design service, additional fees may be required to cover street lighting design revision work as a result of the Developer's layout changes.

## **14.2 SERVICES**

- 14.2.1 The developer shall be responsible for provision of electricity services to the lighting units or supply pillars. All services shall be laid underground.
- 14.2.2 The electricity company shall provide electricity services to each lighting unit. The developer may be required to provide black service ducts for electricity company services cables. Such ducts shall be installed to the relevant electricity company specification.
- 14.2.3 In exceptional circumstances the Highway and Flood Authority may agree to the installation of a "private" service cable to supply street lighting units. Details are available from the Highway and Flood Authority upon request.

### 14.2.4 Trees

The positioning of lighting columns should consider existing and planted trees and their potential crown spread to avoid the need for future clearance pruning.

## **14.3 STANDARDS**

Lighting designs shall conform to BS 5489 Part 1:2013 or any subsequent superseding C.O.P together with regional requirements of the Highway and Flood Authority for lighting levels and specification for materials and installation works.

## **14.4 INSTALLATION**

- 14.4.1 The methods used for installation and erection of highway lighting equipment shall be in compliance with the Code of Practice prepared by the Association of Street Lighting Erection Contractors.

## **14.5 COMPLETION AND COMMISSIONING MAINTENANCE**

- 14.5.1 The developer shall inform the Highway and Flood Authority when each lighting unit is commissioned. The developer shall also provide Electrical Test Certificate for each lighting unit. The complete installation details including electrical test certificates shall be handed to the Highway and Flood Authority prior to adoption of the relevant sections of highway.
- 14.5.2 Where the Developer has entered into an Agreement under Section 38 of the Highways Act 1980, maintenance of the highway lighting installation will be governed by the Agreement, which

provides for Developer paying energy charges from commissioning of a properly provided installation and for the installation to be adopted for operation and maintenance by the Highway and Flood Authority at the same time as all the other works in the development. Upon adoption the payment of the energy charges will transfer to the Highway and Flood Authority.

- 14.5.3 Where there is no Agreement under Section 38 of the Highways Act 1980 the Highway and Flood Authority will not maintain the lighting units until the highway has been inspected, adopted and/or has completed its maintenance period.

## 15. PLANTING

---

### 15.1 VERGES AND SUITABLE SuDS FEATURES

Trees can provide environmental benefits to streets and communities and their inclusion in developments should be encouraged, it is important that their inclusion is well designed to prevent high-maintenance requirements in the future.

- 15.1.1 Subject to specific scheme approval, ground cover planting will be considered, in verges (areas between carriageways and footways that do not contain Statutory Undertaker's plant. Areas containing such plant shall be termed Service Margins) as specified and detailed in "The Lincolnshire Development Roads and Sustainable Drainage Design Approach". **Visibility splays shall not be compromised by planting.**

**Planting will NOT be permitted within Service Margins.**

- 15.1.2 Where SuDS features are designed with full infiltration it is encouraged to include tree planting. Tree species used on potentially wet sites such as swales and balancing ponds should be tolerant of periodic waterlogging such as common alder, river birch and swamp cypress.

### 15.2 TREE PLANTING

- 15.2.1 Where trees are permitted within highway limits, they shall not be planted in a manner so as to impede visibility when they are fully grown. Street trees shall normally be over 1.5m to 3.0m height and 8cm minimum girth. They shall be obtained from an approved supplier with planting carried out between early November and March. Usually it is better to plant before mid-December, but on wet heavy soil late planting may be preferable.

- 15.2.2 Planting schemes, including tree species, will require the written approval of the Highway and Flood Authority and shall include details of a suitable root containment system.

- 15.2.3 No Planting is to be carried out in periods of sustained frost or when the ground is frozen.

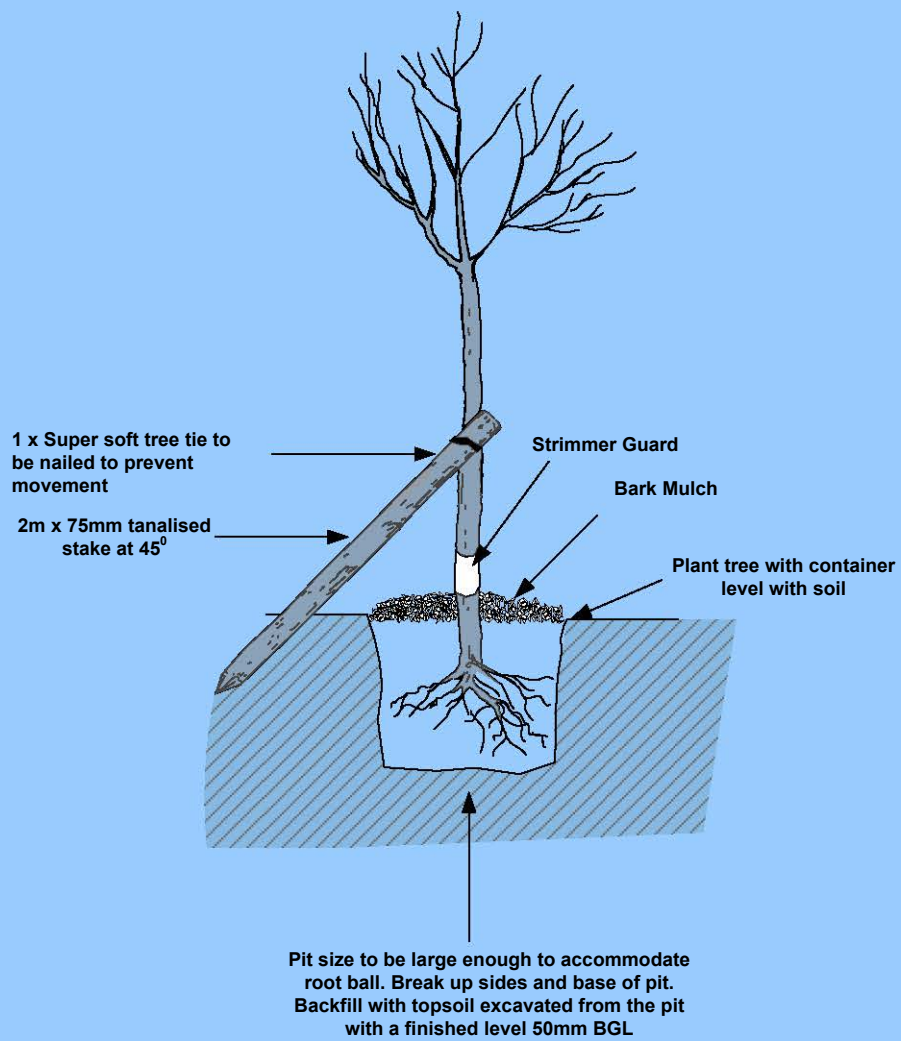
- 15.2.4 All plants should be well formed and healthy conforming to BS 3936.

- 15.2.5 Where trees die in the first year after planting because of poor quality stock or poor planting method, the developer shall replace the trees within 12 months.

- 15.2.6 Acceptable planting methods are as follows:

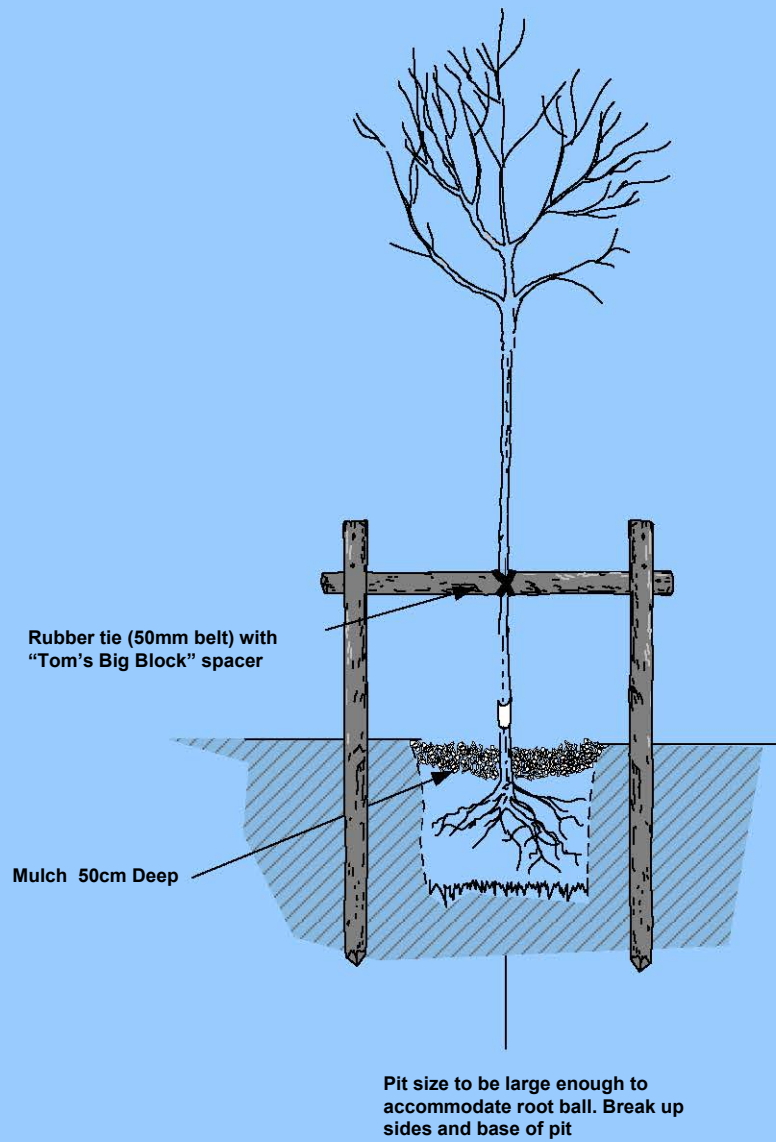
Method 1	-	Single stake
Method 2	-	Double stake and bar
Method 3	-	Double stake, bar and weld mesh cage
Method 4	-	Single stake and weld mesh cage
Method 5	-	Town guard
Method 6	-	Single stake and tree tube
Method 7	-	Bamboo cane and spiral guard
Method 8	-	Single stake and spiral guard

**FIGURE 15/3 - TREE PLANTING DETAIL  
(Method 1) The Single Stake Method**



**FIGURE 15/4 - TREE PLANTING DETAIL  
(Method 2) The Double Stake and Bar Method**

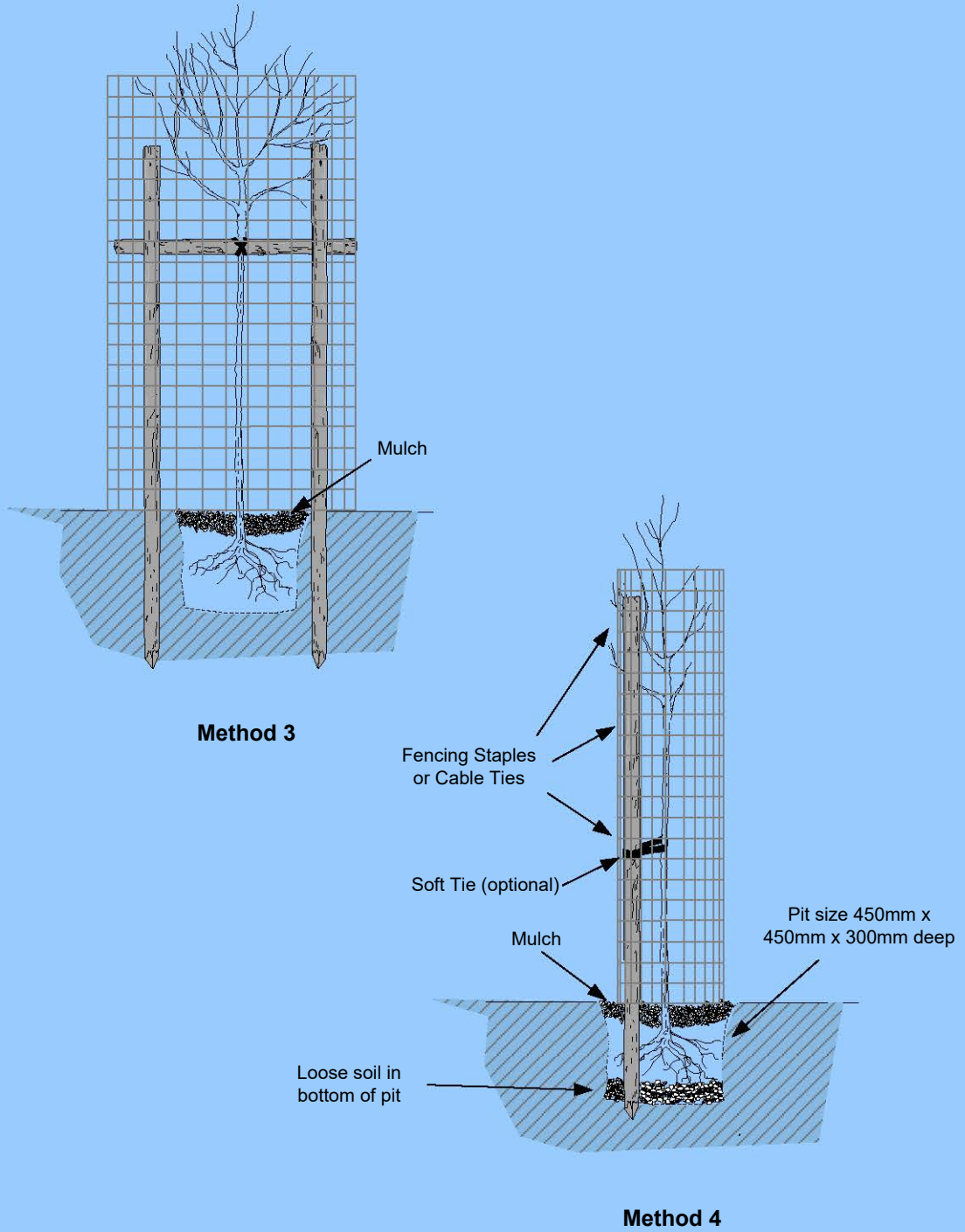
---



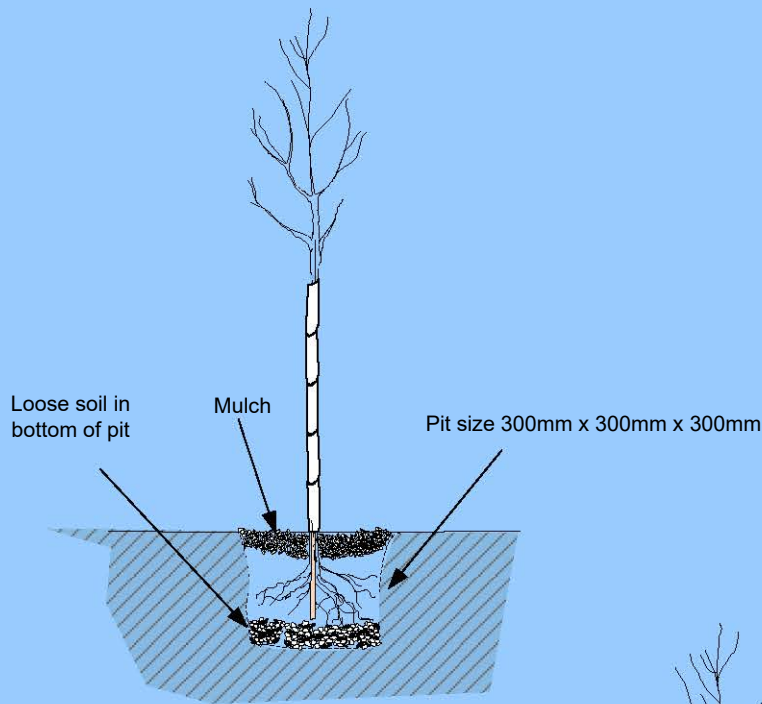
**Notes**

Protect from drying out in summer  
Protect from damage by strimmers

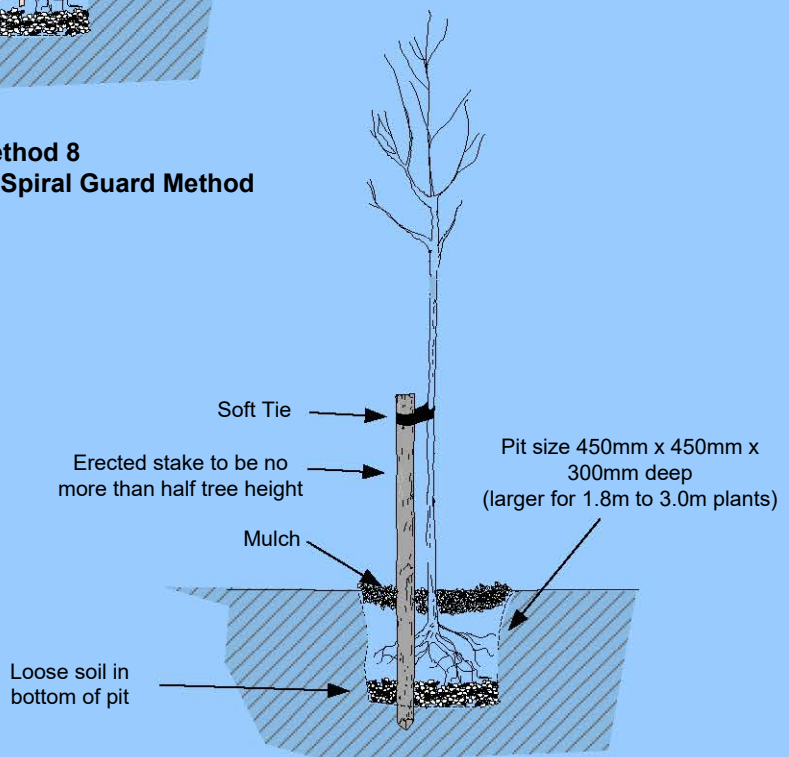
**FIGURE 15/5 - TREE PLANTING DETAIL  
(Methods 3 & 4) Mesh Supported Trees**



**FIGURE 15/6 - TREE PLANTING DETAIL  
(Methods 7 & 8) Spiral Guard Methods**



**Method 8  
Bamboo Cane & Spiral Guard Method**



**Method 8  
Single Stake & Spiral Guard Method**



### **15.3 CHOICE OF SPECIES**

- 15.3.1 The most important consideration for tree planting on development sites is the choice of species, this determines the potential size and growth-form of the tree as well as long-term structural integrity and amenity value. The species and variety must be suited to the soil type and growing conditions, urban sites can be hotter and drier than rural in the same vicinity. The variety of tree must fit its growing space at maturity without the need for frequent pruning. Some species and varieties may be too vigorous for urban situations, or prone to break-up in maturity so the choice of tree variety must be approved by the County Council arboricultural officer.
- 15.3.2 Tree planting choice should be diverse with no single variety making up more than 30% of the population.

### **15.4 TREE ROOTS**

- 15.4.1 Where trees are planted within 5m of vulnerable underground services they must be planted in pits surrounded by root barrier extending from the ground surface to 1m depth, the planting pits to be not less than 1m in diameter.
- 15.4.2 Permeable paving can be vulnerable to disruption to root ingress in the long-term, where permeable paving is to be used trees must be planted in pits surrounded by root barrier as 15.2.7
- 15.4.3 Where trees are to be planted into land adjacent to that to be adopted root barrier is to be installed if the base of the tree is within 10m of permeable paving or of vulnerable underground services.
- 15.4.4 Trees with vigorous, shallow roots such as wild cherry should not be used in paved areas or on sandy soils.

### **15.5 SHRINKABLE SOILS**

- 15.5.1 The nature of the soil must be considered when designing tree planting, where the soil is known to be shrinkable: some clays and peat soils, vigorous and potentially large trees must be avoided in the vicinity of buildings. The distance from the tree to building should not be less than the ultimate height of the tree, unless the building has been constructed to allow for shrinkable soils.

### **15.6 TREES AND STREET LIGHTING**

- 15.6.1 The positioning of tree planting should take into account their expected height and spread, trees should not be planted where their crowns will grow within 2m of buildings or within 5m of street lighting columns.

### **15.7 RETAINED TREES**

Existing trees that are retained on developments and are to be adopted as part of the highway must be protected throughout the development process as specified in BS5837:2012 Trees in relation to design, demolition and construction – Recommendations. Their rooting area must be protected from compaction, excavations and contamination so that they remain viable and in good condition.

## **16. INDUSTRIAL DEVELOPMENT ROADS**

---

### **16.1 HEAVY INDUSTRIAL ESTATE ROAD**

- 16.1.1 These roads are defined as those designed to carry more than 2.0 m.s.a. This document does not contain Construction Charts for such roads which will be subject to individual design using materials specified in this document and based on anticipated m.s.a over a 40 year life span. Specific advice will need to be sought from the Highway and Flood Authority regarding the design of such roads.
- 16.1.2 This document contains Construction Charts for industrial estate roads designed to carry 2.0msa or less over a 40 year design life span.

## 17. PUBLICATIONS

---

All publications listed are the current editions unless otherwise specified.

### 17.1 BRITISH STANDARDS

Published by British Standards Institution, 389 Chiswick High Road, London, W4, 4AL.

<b>BS</b>	<b>Title</b>
65	Vitrified clay pipes and joints
EN124	Manhole covers, road gully gratings and frames for drainage purposes
EN206	Concrete, specification, performance, production and conformity
EN295	Vitrified clay pipes
EN317	Particleboards and fibreboards
434	Bitumen road emulsions
437	Cast iron spigot and socket drain pipes and fittings
EN545	Ductile iron pipes, fittings, accessories and their joints for water pipelines
EN598	Ductile iron pipes, fittings, accessories and their joints for sewerage
598	Sampling and examination of bituminous mixtures for roads and other
743	Specification for materials for damp-proof courses
EN752	Drain and sewer systems outside buildings planning
EN771-1	Specification for masonry units. Clay masonry units
EN771-3	Specification for masonry units. Aggregate concrete masonry units
EN772	Methods of test for masonry units
812	Testing aggregates
EN1097	Tests for mechanical and physical properties of aggregates
1247	Manhole step irons
EN1338	Concrete Paving Blocks. Requirements and Test Material.
EN1295-1	Structural design of buried pipelines under various conditions of loading
EN1339	Concrete paving blocks. Requirements and Test Material
EN 1340	Concrete Kerb Units – Requirements and test methods
EN1344	Clay pavers. Requirements and Test Methods
1377	Methods of test for soils for civil engineering purposes
EN1388	Concrete paving blocks. Requirements and test methods
EN1401	Plastic piping systems for non-pressure underground drainage and sewerage
EN1436	Road Marking materials – Road marking performance for road users
EN1452	Joints and fittings for use with Unplasticised PVC pressure pipes
EN ISO 1461	Specification for hot dip galvanised coatings on iron and steel articles
EN1744	Tests for chemical properties of aggregates
EN1996	Design of Masonry Structures
ISO 2602	Guide to statistical interpretation of data. Estimation of mean: confidence
2782-4	Method 452B:1993 Methods of testing plastics. Chemical properties.
3882	Specification for Topsoil
3969	Turf for general purposes
4729	Specification for dimensions of bricks of special shapes and sizes
4962	Plastic pipes and fittings for use as subsoil field drains
5178	Prestressed concrete pipes for drainage and sewage
5489	Road lighting (Part 1-10)
5911	Precast concrete pipes and fittings for drainage and sewage
5930	Site investigation
6398	Specification for bitumen damp-proof courses for masonry
6515	Specification for polyethylene damp-proof courses for masonry
7533	Guide for structural design of pavements constructed with clay or concrete block pavers
7533-3	Code of Practice for laying precast concrete paving blocks and clay pavers for flexible pavements.

7533-13	Guide for the design of permeable pavements constructed with concrete paving blocks and flags, natural stone slabs and setts and clay pavers.
7671	Requirements for electrical installations
8204-2	Screeds, bases and in situ floorings concrete wearing surfaces. Code of Practice
8215	Code of Practice for the Design and Installation in damp-proof courses in masonry construction
8420	Methods of measuring irregularities on surfaces of roads, footways and other paved areas using straight edges and wedges
8500	Concrete, Complementary British Standard to BSEN206-1
8515	Rainwater harvesting systems. Code of Practice
EN ISO 9001	Quality management systems, Requirements
EN ISO 9004	Quality management systems, Guidelines for performance improvements
10175	Investigation of potentially contaminated sites. Code of Practice
EN ISO 10319	Geotextiles. Wide width tensile test
EN ISO 11058	Geotextiles and geotextile related products : determination of water permeability
EN ISO 12460-5	Wood based panels
BS EN 12591	Bitumen and bituminous binders. Specifications for paving grade bitumen.
EN12620	Aggregates for concrete
EN 12697	Bituminous mixtures. Test methods for hot mix asphalt
EN ISO 12956	Geotextiles and geotextile related products. Determination of the characteristic
EN ISO 12958	Geotextiles and geotextile related products. Determination of water flow capacity in their plane
EN13043	Aggregates for bituminous mixtures and surface treatments for roads, airfields
EN13101	Steps for underground man entry chambers
EN 13108	Bituminous mixtures. Material specifications
EN13139	Aggregates. Aggregates for mortar
EN13201	Road Lighting
EN13242	Aggregates for unbound and hydraulically bound materials for use in civil
EN13285	Unbound mixtures. Specification
EN13286	Unbound and hydraulically bound mixtures
EN 13808	Bitumen and bituminous binders. Framework for specifying cationic bituminous
EN14364	Plastic piping systems for drainage and sewerage with or without pressure
EN ISO / ICC 17021	Conformity assessment - Requirements for bodies providing audit and certification of management systems
EN ISO / IEC 17025	General requirements for the competence of testing and calibration laboratories
594987	Asphalt for roads and other paved areas. Specification for transport, laying and compaction and type testing protocols

**PD**

**Title**

6678	Guide to the specification of masonry mortar – Possible BS EN998
6682	Aggregates. Guidance on their use
6691	Guidance on the use of BS EN 13108 Bituminous mixtures – Material
6692	Guidance on the use of BS EN 12697 “Bituminous mixtures – Test methods for
CEN/TR 15019	Geotextiles and geotextile – related products – on site quality control

## 17.2 **OTHER PUBLICATIONS**

### **Published by TSO (The Stationery Office), St Crispins, Duke Street, Norwich, NR3 1PD**

Department for Transport, Traffic Signs Regulations and General Directions.

Department for Transport, Traffic Signs Manual – Chapter 3 Regulatory Signs, Chapter 4 Warning Signs, Chapter 5 Road Markings, Chapter 7 The Design of Traffic Signs and Chapter 8: Traffic Safety Measures for Signs for Roadworks and Temporary Situations.

Highways England, Specification for Highway Works.

Highways England, Notes of Guidance on the Specification for Highway Works

Highways England, Design Manual for Roads and Bridges – Volume 4: Geotechnics and Drainage; Volume 7: Pavement Design and Maintenance.

Department of the Environment Transport and the Regions, Design Bulletin 32 (Second Edition): Residential Roads and Footpaths.

New Roads and Street Works Act 1991. Highways

Act 1980.

Health and Safety at Work Act 1974. Traffic

Management Act 2004.

### **Published by TRL (Transport Research Laboratory), Crowthorne House, Nine Mile Ride, Wokingham, Berks RG40 3GA**

Laboratory Report 4: Cooling of Bituminous Layers and Time Available for their Compaction.

Laboratory Report 456: Coated Chippings for Asphalt.

Laboratory Report 1132: The Structural Design of Bituminous Roads. TRL

Report 447: Sulfate Specification for Structural Backfills.

### **Published by the Association of Street Lighting Electrical Contractors, Bowden House, 1 Church Street, Henfield, West Sussex, BN59NS**

Code of Practice for the Erection of Street Lighting Equipment.

### **Published by the Institution of Civil Engineers, Great George Street, Westminster, London SW1**

Report of the Joint Committee on Location of Underground Services.

### **Published by the National Joint Utilities Group, 30 Millbank, London SW1 4RD**

Volume 1 - NJUG Guidelines on the positioning and colour coding of Underground

Utilities' Apparatus.

Volume 2 - NJUG Guidelines on the positioning of underground utilities apparatus for New Development Sites

**Published by Lincolnshire County Council, County Offices, Newland, Lincoln LN1 1DN**

Highways and Planning Code of Practice – Highway Works: Standards, Materials, Testing

Lincolnshire Development Roads and Sustainability Drainage Design Approach

A Guide to Parking Provision

**Published by Water Research Centre, Frankland Road, Blagrove, Swindon, Wiltshire SN5 8YF**

Model Contract Document for sewer condition inspection

**Published by the Association of Directors of Environment, Economy, Planning and Transport (ADEPT) – Previously the County Surveyors Society (CSS)**

Managing Reclaimed Asphalt – Highways and Pavements.

**Published by Anglian Water, Developer Services, P O Box 495, Huntingdon, Cambridgeshire, PE29 6YY**

SuDs (Sustainable Urban Drainage System) Adoption Manual

**Published by CIRIA (Construction Industry Research and Information Association), Griffon Court, 15 Long Lane, London EC1A 9PN**

Sustainable Drainage Systems (SuDs) Manual C753 – C.I.R.A

**Published by DEFRA (Department for Environment, Food and rural Affairs), Nobel House, 17 Smith Square, London SW1P 3JR**

Not statutory Technical Standards for Sustainable Drainage – Local Authority SuDS Officer Organisation (LASOO).

**Published by Thomas Telford Publishing, 1 Heron Quay, London E14 4JD for the Department of Transport.**

Manual for Streets 1

**Published by the Chartered Institution of Highways and Transportation, 119 Britannia Walk, London N1 7JE**

Manual for Streets 2

**Published by Water UK, 3<sup>rd</sup> Floor, 36 Broadway, Westminster, London SW1H 0BH**

Sewers for Adoption 7<sup>th</sup> Edition – A Design & Construction Guide for Developer

**Published by The Environment Agency, Horizon House, Deanery Road,  
Bristol.  
BS1 9AH**

Rainfall Run-off Management for Developments - SC030219

Flooding and Coastal Change: Flood risk assessments - climate change allowances

**APPENDICES**

---



## APPENDIX 1

### KEY CONSTRUCTION AND INSPECTION STAGE CERTIFICATES

#### Key stages and Certificates of Construction

Traditional Construction (T)	SUDs Construction (S)
Key Stage <b>T1</b> - Drainage	Certification for Pervious Pavements <b>S1</b> – stages Drainage to Kerbing.
Key Stage <b>T2</b> – Site Investigation/Formation/Earthworks	
Key Stage <b>T3</b> – Carriageway Subbase	
Key Stage <b>T4</b> – Kerbing	
Key Stage <b>T5</b> – Carriageway Binder Course	
Key Stage <b>T6</b> – Footways	
Key Stage <b>T7</b> – Block Paving	Certification for Pervious Pavements <b>S2</b> – Permeable Block Paving
Key Stage <b>T8</b> – Carriageway Surface Course	Certification for Swales & Filter Strips <b>S3</b>
Key Stage Inspection – Pre-Maintenance Period Inspection	
Key Stage Inspection – Pre-Adoption Inspection	

#### **NOTE**

The certificates in this appendix are subject to review and amendment. The version of the certificates current at the time the Section 38 agreement is signed will apply to works covered by that agreement.

The certificates are now in electronic format and can be downloaded via the Lincolnshire County Council web site. The downloadable versions of the Key Stage Certificates are available at [www.lincolnshire.gov.uk/DRS](http://www.lincolnshire.gov.uk/DRS)

## DEVELOPMENT ROAD CONSTRUCTION CERTIFICATE

### KEY STAGE T1 – DRAINAGE

In accordance with the Section 38 Agreement for the development known as:-

General Information	
<b>Development</b>	
<b>Developer</b>	

The developer is required to obtain from the County Council, as Highway Authority, certification that the DRAINAGE works on this development have been carried out in accordance with the specification and agreed drawings and inspected and tested by an authorised representative of the County Council at the correct time.

In order to meet the above requirements, the nominated person named in accordance with the Section 38 Agreement as being responsible for managing construction and quality for the developer, in addition to ensuring compliance with this specification, shall notify in good time (**a minimum of five working days' notice**) and provide facility for the authorised representative of the County Council to carry out the critical inspections and tests detailed below:-

Critical Inspections/Tests			
Inspection or Test	Essential	Frequency	Date passed by LCC Authorised Representative
Verification of material sources for pipes, PCC units, covers/ frames, bedding and backfill material	Yes	All lengths	
Inspection of excavation and pipe bed	Yes	All lengths	
Inspections of line and level of laid pipes	Yes	All lengths	
Inspection of backfill and compaction (including on pipelines to be adopted by water company under S104 Agreement)	Yes	All lengths	
Air tests on pipelines (Water tests may be required if air test not satisfactory).	Yes	Each length between manholes	

Should the nominated representative of the developer fail to notify, inform or allow facility for the authorised representative of the County Council to carry out the above Critical Inspections and Tests at the correct time, then the County Council will require retrospective testing, to be determined by the authorised representative, to be carried out, at the developer's expense, which will include the following as a minimum:-

<b>Retrospective Inspections/Tests</b>		
<b>Inspection or Test</b>	<b>Essential</b>	<b>Frequency</b>
Detailed investigation of backfill suitability and compaction	Yes	One per 100m (minimum three per site)
Verification of material sources for pipes PCC units, covers/frames, bedding and backfill materials	Yes	All lengths
CCTV survey of pipelines	Yes	All lengths
Air tests on pipelines (Water tests may be required if air test not satisfactory)	Yes	Each length between manholes
Level survey	Yes	All lengths

**Payment by the Developer for Failure to Achieve Certification of the Key Stage of Construction of DRAINAGE**

In addition and irrespective of any retrospective testing or the outcome of such tests, should the Developer fail to obtain the relevant certificate for the key stage of DRAINAGE Works on this development or proceed without the consent of the Executive Director for Place (or persons authorised by him), then the Council will require the Developer to pay a sum to the Council to cover possible future risk to the Authority associated with the lack of inspection and/or testing at the correct stage. This will be calculated as 10% of the estimated cost of the drainage works, discounted over a 120 year period, plus 10% of the estimated cost of the carriageway sub-base binder course and surface course, discounted over a 40 year period, as determined by the County Council.

**The alternative course of action to the above is for the Developer to remove all works and materials down to the lowest stage of construction which has an approval certificate to allow the specified inspections and testing to take place in accordance with the Section 38 Agreement.**

**CERTIFICATION OF DEVELOPMENT ROAD CONSTRUCTION  
KEY STAGE T1 - DRAINAGE**

This is to certify that the key construction stage of DRAINAGE has been satisfactorily notified and completed by:-

<b>General Information</b>	
<b>Development</b>	
<b>Developer</b>	

Development and that the key inspections and the key tests, above, have been successfully completed.

<b>Authorised representative of the County Council on behalf of the Executive Director for Place</b>	
Signed:	
Date:	
<b>Lincolnshire County Council Technical Manager – Development Management</b>	
Counter Signed:	
Date:	

**Notwithstanding the above, the responsibility for all works and supervision on Development Roads lies with the developer. It is totally his responsibility to ensure and achieve compliance with the specification. Inspections and testing carried out by Lincolnshire County Council and this certification do not absolve the developer from this responsibility in any way.**

**NOTIFICATION OF FAILURE TO OBTAIN CERTIFICATION OF DEVELOPMENT ROAD  
CONSTRUCTION**

**KEY STAGE T1 - DRAINAGE**

<b>General Information</b>	
<b>Development</b>	
<b>Developer</b>	

You are hereby informed that the key construction stage of DRAINAGE was not notified by yourselves and inspected and tested wholly in accordance with the specification and as required by the Section 38 Agreement and as you have now commenced a subsequent stage of construction the following retrospective testing will be required:-

<b>Retrospective Inspections/Tests</b>		
<b>Inspection or Test</b>	<b>Essential</b>	<b>Frequency</b>
Detailed investigation of backfill suitability and compaction	Yes	One per 100m (minimum three per site)
Verification of material sources for pipes PCC units, covers/frames, bedding and backfill materials	Yes	All lengths
CCTV survey of pipelines	Yes	All lengths
Air tests on pipelines (Water tests may be required if air test not satisfactory)	Yes	Each length between manholes
Level survey	Yes	All lengths

Please inform the authorized representative of the county Council below, when the above tests are to be carried out and by whom. NB only tests carried out by a UKAS accredited laboratory or organization will be acceptable.

**Payment by the Developer for Failure to Achieve Certification of the  
Key Stage of Construction of DRAINAGE**

In addition, and irrespective of any retrospective testing or the outcome of such tests, you are informed that a letter will be sent to \_\_\_\_\_ informing of the County Council's requirement for you to pay a sum to the County Council to cover possible future risk to the authority associated with the lack of inspection and testing at this stage. This will be calculated as 10% of the estimated cost of the drainage works, discounted over a 120 year period, plus 10% of the estimated cost of the carriageway sub-base, binder course and surface course, discounted over a 40 year period, as determined by the County Council.

**The alternative course of action to the above is for the Developer to remove all works and materials down to the lowest stage of construction which has an approval certificate to allow the specified inspections and testing to take place in accordance with the Section 38 Agreement.**

**NOTIFICATION OF FAILURE TO OBTAIN CERTIFICATION OF DEVELOPMENT ROAD  
CONSTRUCTION**

**KEY STAGE T1 - DRAINAGE**

<b>Authorised representative of the County Council on behalf of the Executive Director for Place</b>
Signed:   
Date:   
<b>Lincolnshire County Council Technical Manager – Development Management</b>
Counter Signed:   
Date:   

**NOTIFICATION OF FAILURE TO OBTAIN CERTIFICATION OF DEVELOPMENT ROAD  
CONSTRUCTION**

**KEY STAGE T1 – DRAINAGE**

<b>General Information</b>	
<b>Development</b>	
<b>Developer</b>	

You are hereby informed that the key construction stage of DRAINAGE was not notified by yourselves and inspected and tested wholly in accordance with the specification and as required by the Section 38 Agreement and as you have now commenced a subsequent stage of construction the following retrospective testing will be required:-

<b>Retrospective Inspections/Tests</b>		
<b>Inspection or Test</b>	<b>Essential</b>	<b>Frequency</b>
Detailed investigation of backfill suitability and compaction	Yes	One per 100m (minimum three per site)
Verification of material sources for pipes PCC units, covers/frames, bedding and backfill materials	Yes	All lengths
CCTV survey of pipelines	Yes	All lengths
Air tests on pipelines (Water tests may be required if air test not satisfactory)	Yes	Each length between manholes
Level survey	Yes	All lengths

Please inform the authorized representative of the county Council below, when the above tests are to be carried out and by whom. NB only tests carried out by a UKAS accredited laboratory or organization will be acceptable.

**Payment by the Developer for Failure to Achieve Certification of the  
Key Stage of Construction of DRAINAGE**

In addition, and irrespective of any retrospective testing or the outcome of such tests, you are informed that a letter will be sent to \_\_\_\_\_ informing of the County Council's requirement for you to pay a sum to the County Council to cover possible future risk to the authority associated with the lack of inspection and testing at this stage. This will be calculated as 10% of the estimated cost of the drainage works, discounted over a 120 year period, plus 10% of the estimated cost of the carriageway sub-base, binder course and surface course, discounted over a 40 year period, as determined by the County Council.

**The alternative course of action to the above is for the Developer to remove all works and materials down to the lowest stage of construction which has an approval certificate to allow the specified inspections and testing to take place in accordance with the Section 38 Agreement.**

**NOTIFICATION OF FAILURE TO OBTAIN CERTIFICATION OF DEVELOPMENT ROAD  
CONSTRUCTION**

**KEY STAGE T1 – DRAINAGE**

<b>Authorised representative of the County Council on behalf of the Executive Director for Place</b>
Signed:   
Date:   
<b>Lincolnshire County Council Technical Manager – Development Management</b>
Counter Signed:   
Date:   



**NOTIFICATION OF FAILURE TO OBTAIN CERTIFICATION FOR A DEVELOPMENT KEY CONSTRUCTION STAGE**

**KEY STAGE T1 - DRAINAGE**

You are hereby informed that the key construction stage of Drainage

<b>General Information</b>	
<b>Developers Name</b>	
<b>Phase</b>	
<b>Site location</b>	

was not notified by yourselves and inspected and tested wholly in accordance with the specification and as required by the Section 38 Agreement and as you have now commenced a subsequent stage of construction the following retrospective testing will be required:-

Retrospective Tests/Inspections

Inspection or Test	Essential	Frequency
Detailed investigation of backfill suitability and compaction	√	1/100m min 3 per site
Verification of material sources for pipes PCC units, covers/frames, bedding and backfill	√	All lengths
CCTV survey of pipelines	√	All lengths
Air tests on pipelines (Water tests may be required if air test not satisfactory)	√	Each length between
Level survey	√	All lengths

Please inform the authorized representative of the county Council below, when the above tests are to be carried out and by whom. NB only tests carried out by a UKAS accredited laboratory or organization will be acceptable.

**Payment by Developer for failure to Achieve Certification of the Key Stage of Construction Drainage**

In addition, and irrespective of any retrospective testing or the outcome of such tests, you are informed that a letter will be sent to .....

informing of the

County Council's requirement for you to pay a sum to the County Council to cover possible future risk to the authority associated with the lack of inspection and testing at this stage. This will be calculated as 10% of the estimated cost of the drainage works, discounted over a 120 year period, plus 10% of the estimated cost of the carriageway sub-base, binder course and surface course, discounted over a 40 year period, as determined by the County Council.

**The alternative course of action to the above is for the Developer to remove all works and materials down to the lowest stage of construction which has an approval certificate to allow the specified inspections and testing to take place in accordance with the Section 38 Agreement.**

**NOTIFICATION OF FAILURE TO OBTAIN CERTIFICATION FOR A  
DEVELOPMENT KEY CONSTRUCTION STAGE**

**KEY STAGE T1 - DRAINAGE**

Signed ..... Authorised representative of the County  
Council on behalf of the Executive Director  
for Environment and Economy

Date .....

Counter Signed ..... Lincolnshire County Council  
Technical Manager - Development

Date .....

## DEVELOPMENT ROAD CONSTRUCTION CERTIFICATE

### KEY STAGE S1 – PERMEABLE PAVING

#### (Stages Drainage to Kerbing - Direct & Partial Infiltration)

In accordance with the Section 38 Agreement for the development known as:-

General Information	
<b>Development</b>	
<b>Developer</b>	

The developer is required to obtain from the County Council, as Highway Authority, certification that the DRAINAGE, SITE INVESTIGATION / FORMATION / EARTHWORKS / GEOTEXTILE, CARRIAGEWAY SUB-BASE, KERBING AND CHANNELLING works on this development have been carried out in accordance with the specification and agreed drawings and inspected and tested by an authorised representative of the County Council at the correct time.

In order to meet the above requirements, the nominated person named in accordance with the Section 38 Agreement as being responsible for managing construction and quality for the developer, in addition to ensuring compliance with this specification, shall notify in good time (**a minimum of five working days' notice**) and provide facility for the authorised representative of the County Council to carry out the critical inspections and tests detailed below:-

### Information Required

- Site Investigation Report
- Brownfield or Greenfield Site Classification
- Contamination Risk Assessment
- Determine existing ground water table depth

Critical Inspections/Tests			
Inspection or Test	Essential	Frequency	Date passed by LCC Authorised Representative
Verification of approved sub-base material and sample tested	Yes	One sample prior to use	
Confirm voids ratio for sub-base material	Yes	One sample prior to use	
Verification of approved geotextile	Yes	All lengths	
Confirm all shallow services are located within service corridors	No	As required (all lengths)	

<b>Critical Inspections/Tests</b>			
<b>Inspection or Test</b>	<b>Essential</b>	<b>Frequency</b>	<b>Date passed by LCC Authorised Representative</b>
Inspection of backfill & compaction of all pipelines to be adopted by water company under S104 Agreement	No	As required (all lengths)	
Verification of protection method of any pipework	No	As required (all lengths)	
Confirm check dam locations and construction detail	No	As required (all lengths)	
Removal of vegetation/topsoil	Yes	All lengths	
Inspection of formation and levels	Yes	All lengths	
Check for soft spots, made up ground and agree remedial action	Yes	All lengths	
Inspection of backfilling of all pits, service trenches, redundant land, drainage, etc. (with Type 1 or Type 3 sub-base material)	Yes	All lengths	
Inspection of pipework, including bedding material and backfill and CCTV survey carried out, as required	Yes	All lengths	
Laying and lapping of geotextile - ensuring enough overhang is left to run up the back of the back of the kerb race	Yes	All lengths	
Bulk sample testing – Type 3 Sub-base	No	As required (one per 150 tonnes)	
Kerb race inspection, including line and level, dimensions and verification of concrete mix	Yes	All lengths	
Inspection of kerb line, levels and correct up stands/kerb face	Yes	All lengths	
Inspection of sub-base for contamination	Yes	All lengths	
Check sub-base depth	Yes	One per 50m	
Dynamic Plate test (DWT) Or Plate bearing test (PBT)	Yes	One per 10m (DWT) Minimum two per site (PBT)	

Should the nominated representative of the developer fail to notify, inform or allow facility for the authorised representative of the County Council to carry out the above Critical Inspections and Tests at the correct time, then the County Council will require retrospective testing, to be determined by the authorised representative, to be carried out, at the developer's expense, which will include the following as a minimum:-

<b>Retrospective Inspections/Tests</b>		
<b>Inspection or Test</b>	<b>Essential</b>	<b>Frequency</b>
Verification of approved materials source (including confirmation of non-frost susceptibility) and verification of backfill materials - may require sample analysis	Yes	One per 100m (minimum two per site)
Confirmation that contamination is not a problem and review past uses	Yes	All lengths
CCTV survey of pipelines	Yes	All lengths
Verification of depth and CBR values (through trial pits)	Yes	One per 100m (minimum two per site)
Verification of correct geotextile, laying & lapping methods	Yes	All lengths
Plate Bearing test to assess compaction of capping and or sub-base	Yes	One per 100m (minimum two per site)
Verification of check dam detail and locations	Yes	As required
Inspection of kerb race, including line, level & dimension	Yes	All lengths
Verification of correct concrete	Yes	All lengths
Verification of correct kerb lines, level control, faces and up stands	Yes	All lengths
Level survey	Yes	As required

**Payment by the Developer for Failure to Achieve Certification of the  
Key Stage of Construction of PERMEABLE PAVING  
(Stages Drainage to Kerbing Direct & Partial Infiltration)**

In addition and irrespective of any retrospective testing or the outcome of such tests, should the Developer fail to obtain the relevant certificate for PERMEABLE PAVING (Stages Drainage to Kerbing - Direct & Partial Infiltration) on this development or proceed without the consent of the Executive Director for Place (or persons authorised by him), then the Council will require the Developer to pay a sum to the Council to cover possible future risk to the Authority associated with the lack of inspection and/or testing at the correct stage. This will be calculated as 10% of the overall replacement cost of the Permeable Paving - Stages Drainage to Kerbing, discounted over a 40 year period, as determined by the County Council.

**The alternative course of action to the above is for the Developer to remove all works and materials down to the lowest stage of construction which has an approval certificate to allow the specified inspections and testing to take place in accordance with the Section 38 Agreement.**

**CERTIFICATION OF DEVELOPMENT ROAD CONSTRUCTION**

**KEY STAGE S1 – PERMEABLE PAVING**

**(Stages Drainage to Kerbing - Direct & Partial Infiltration)**

This is to certify that the key construction stage of PERMEABLE PAVING (Stages Drainage to Kerbing - Direct & Partial Infiltration) has been satisfactorily notified and completed by:-

General Information	
<b>Development</b>	
<b>Developer</b>	

Development and that the key inspections and the key tests, above, have been successfully completed.

Authorised representative of the County Council on behalf of the Executive Director for Place
Signed:   
Date:   
Lincolnshire County Council Technical Manager
Counter Signed:   
Date:   

**Notwithstanding the above, the responsibility for all works and supervision on Development Roads lies with the developer. It is totally his responsibility to ensure and achieve compliance with the specification. Inspections and testing carried out by Lincolnshire County Council and this certification do not absolve the developer from this responsibility in any way.**

**NOTIFICATION OF FAILURE TO OBTAIN CERTIFICATION OF DEVELOPMENT ROAD  
CONSTRUCTION**

**KEY STAGE S1 – PERMEABLE PAVING**

**(Stages Drainage to Kerbing - Direct & Partial Infiltration)**

<b>General Information</b>	
<b>Development</b>	
<b>Developer</b>	

You are hereby informed that the key construction stage of Drainage was not notified by yourselves and inspected and tested wholly in accordance with the specification and as required by the Section 38 Agreement and as you have now commenced a subsequent stage of construction the following retrospective testing will be required:-

<b>Retrospective Inspections/Tests</b>		
<b>Inspection or Test</b>	<b>Essential</b>	<b>Frequency</b>
Verification of approved materials source (including confirmation of non-frost susceptibility) and verification of backfill materials - may require sample analysis	Yes	One per 100m (minimum two per site)
Confirmation that contamination is not a problem and review past uses	Yes	All lengths
CCTV survey of pipelines	Yes	All lengths
Verification of depth and CBR values (through trial pits)	Yes	One per 100m (minimum two per site)
Verification of correct geotextile, laying & lapping methods	Yes	As lengths
Plate Bearing test to assess compaction of capping and or sub-base	Yes	One per 100m (minimum two per site)
Verification of check dam detail and locations	Yes	As required
Inspection of kerb race, including line, level & dimension	Yes	All lengths
Verification of correct concrete	Yes	All lengths
Verification of correct kerb lines, level control, faces and up stands	Yes	All lengths
Level survey	Yes	As required

Please inform the authorized representative of the county Council below, when the above tests are to be carried out and by whom. NB only tests carried out by a UKAS accredited laboratory or organization will be acceptable.

**Payment by the Developer for Failure to Achieve Certification of the  
Key Stage of Construction of PERMEABLE PAVING  
(Stages Drainage to Kerbing Direct & Partial Infiltration)**



In addition, and irrespective of any retrospective testing or the outcome of such tests, you are informed that a letter will be sent to \_\_\_\_\_ informing of the County Council's requirement for you to pay a sum to the County Council to cover possible future risk to the authority associated with the lack of inspection and testing at the correct stage. This will be calculated as 10% of the overall construction works less the cost of drainage (provided that this has been previously certified) discounted over a 40 year period, as determined by the County Council.

**The alternative course of action to the above is for the Developer to remove all works and materials down to the lowest stage of construction which has an approval certificate to allow the specified inspections and testing to take place in accordance with the Section 38 Agreement.**

**NOTIFICATION OF FAILURE TO OBTAIN CERTIFICATION OF DEVELOPMENT ROAD CONSTRUCTION**

**KEY STAGE S1 – PERMEABLE PAVING**

**(Stages Drainage to Kerbing - Direct & Partial Infiltration)**

<b>Authorised representative of the County Council on behalf of the Executive Director for Place</b>
Signed:
Date:
<b>Lincolnshire County Council Technical Manager</b>
Counter Signed:
Date:

**CERTIFICATION OF DEVELOPMENT ROAD CONSTRUCTION**

**KEY STAGE S1 – PERMEABLE PAVING**

**(Stages Drainage to Kerbing - Direct & Partial Infiltration)**

This is to certify that the key construction stage of PERMEABLE PAVING (Stages Drainage to Kerbing - Direct & Partial Infiltration) has been satisfactorily notified and completed by:-

<b>General Information</b>	
<b>Development</b>	
<b>Developer</b>	

Development and that the key inspections and the key tests, above, have been successfully completed.

<b>Authorised representative of the County Council on behalf of the Executive Director for Place</b>
Signed:
Date:
<b>Lincolnshire County Council Technical Manager</b>
Counter Signed:
Date:

**Notwithstanding the above, the responsibility for all works and supervision on Development Roads lies with the developer. It is totally his responsibility to ensure and achieve compliance with the specification. Inspections and testing carried out by Lincolnshire County Council and this certification do not absolve the developer from this responsibility in any way.**

**NOTIFICATION OF FAILURE TO OBTAIN CERTIFICATION OF DEVELOPMENT ROAD  
CONSTRUCTION**

**KEY STAGE S1 – PERMEABLE PAVING**

**(Stages Drainage to Kerbing - Direct & Partial Infiltration)**

<b>General Information</b>	
<b>Development</b>	
<b>Developer</b>	

You are hereby informed that the key construction stage of Drainage was not notified by yourselves and inspected and tested wholly in accordance with the specification and as required by the Section 38 Agreement and as you have now commenced a subsequent stage of construction the following retrospective testing will be required:-

<b>Retrospective Inspections/Tests</b>		
<b>Inspection or Test</b>	<b>Essential</b>	<b>Frequency</b>
Verification of approved materials source (including confirmation of non-frost susceptibility) and verification of backfill materials - may require sample analysis	Yes	One per 100m (minimum two per site)
Confirmation that contamination is not a problem and review past uses	Yes	All lengths
CCTV survey of pipelines	Yes	All lengths
Verification of depth and CBR values (through trial pits)	Yes	One per 100m (minimum two per site)
Verification of correct geotextile, laying & lapping methods	Yes	As lengths
Plate Bearing test to assess compaction of capping and or sub-base	Yes	One per 100m (minimum two per site)
Verification of check dam detail and locations	Yes	As required
Inspection of kerb race, including line, level & dimension	Yes	All lengths
Verification of correct concrete	Yes	All lengths
Verification of correct kerb lines, level control, faces and up stands	Yes	All lengths
Level survey	Yes	As required

Please inform the authorized representative of the county Council below, when the above tests are to be carried out and by whom. NB only tests carried out by a UKAS accredited laboratory or organization will be acceptable.

**Payment by the Developer for Failure to Achieve Certification of the  
Key Stage of Construction of PERMEABLE PAVING  
(Stages Drainage to Kerbing Direct & Partial Infiltration)**

In addition, and irrespective of any retrospective testing or the outcome of such tests, you are informed that a letter will be sent to \_\_\_\_\_ informing of the County Council's requirement for you to pay a sum to the County Council to cover possible future risk to the authority associated with the lack of inspection and testing at the correct stage. This will be calculated as 10% of the overall construction works less the cost of drainage (provided that this has been previously certified) discounted over a 40 year period, as determined by the County Council.

**The alternative course of action to the above is for the Developer to remove all works and materials down to the lowest stage of construction which has an approval certificate to allow the specified inspections and testing to take place in accordance with the Section 38 Agreement.**

**NOTIFICATION OF FAILURE TO OBTAIN CERTIFICATION OF DEVELOPMENT ROAD CONSTRUCTION**

**KEY STAGE S1 – PERMEABLE PAVING  
(Stages Drainage to Kerbing - Direct & Partial Infiltration)**

<b>Authorised representative of the County Council on behalf of the Executive Director for Place</b>
Signed:   
Date:   
<b>Lincolnshire County Council Technical Manager</b>
Counter Signed:   
Date:   

**NOTIFICATION OF FAILURE TO OBTAIN CERTIFICATION  
FOR A DEVELOPMENT ROAD OF PERVIOUS PAVEMENT S1**

**Permeable Paving – Stages Drainage to Kerbing  
Direct & Partial Infiltration**

You are hereby informed that the Permeable Paving – Stages Drainage to Kerbing

Developers Name	
Phase	
Site location	

was not notified by yourselves and inspected and tested wholly in accordance with the specification and as required by the Section 38 Agreement, and as you have now commenced a subsequent stage of construction, the following retrospective testing will be required:-

Retrospective Tests/Inspections

<b>Inspection or Test</b>	<b>Essential</b>	<b>Frequency</b>
Verification of approved materials source (including confirmation of non-frost susceptibility) and verification of backfill materials - may require sample analysis	√	1/100m min 2/site
Confirmation that contamination is not a problem and review past uses	√	All lengths
CCTV survey of pipelines	√	As required
Verification of depth and CBR values (through trial pits)	√	1/100m min 2/site
Verification of correct geotextile, laying & lapping methods	√	All lengths
Plate Bearing test to assess compaction of capping and or subbase	√	1/100m min 2/site
Verification of check dam detail and locations	√	As required
Inspection of kerb race, including line level & dimension	√	All lengths
Verification of correct concrete	√	All lengths
Verification of correct kerb lines, level control, faces and upstands	√	All lengths
Level survey	√	As required

Please inform the authorized representative of the county Council below, when the above tests are to be carried out and by whom. NB only tests carried out by a UKAS accredited laboratory or organization will be acceptable.

**Payment by Developer for failure to Achieve Certification of the Pervious Pavement S1 – Stages Drainage to Kerbing**

In addition, and irrespective of any retrospective testing or the outcome of such tests, you are informed that a letter will be sent to .....

confirming the County Council's requirement for you to pay a sum to the County Council to cover possible future risk to the authority associated with the lack of inspection and testing at this stage. This will be calculated as 10% of the overall replacement cost of the Pervious Pavement S1-Stages Drainage to Kerbing, discounted over a 40 year period, as determined by the County Council.

**The alternative course of action to the above is for the Developer to remove all works and materials down to the lowest stage of construction which has an approval certificate to allow the specified inspections and testing to take place in accordance with the Section 38 Agreement.**

**NOTIFICATION OF FAILURE TO OBTAIN CERTIFICATION  
FOR A DEVELOPMENT ROAD OF PERVIOUS PAVEMENT S1**

**Permeable Paving – Stages Drainage to Kerbing  
Direct & Partial Infiltration**

Signed ..... Authorised representative of the County Council  
on behalf of the Executive Director for  
Environment & Economy

Date .....

Counter Signed ..... Lincolnshire County Council  
Technical Manager – Development

Date .....

**DEVELOPMENT ROAD CONSTRUCTION CERTIFICATE**  
**DEVELOPMENT ROAD CONSTRUCTION CERTIFICATE**  
**KEY STAGE S2 – PERMEABLE PAVING**

In accordance with the Section 38 Agreement for the development known as:-

General Information	
<b>Development</b>	
<b>Developer</b>	

The developer is required to obtain from the County Council, as Highway Authority, certification that permeable block paving works on this development have been carried out in accordance with the specification and agreed drawings and inspected and tested by an authorised representative of the County Council at the correct time.

In order to meet the above requirements, the nominated person named in accordance with the Section 38 Agreement as being responsible for managing construction and quality for the developer, in addition to ensuring compliance with this specification, shall notify in good time (**a minimum of five working days' notice**) and provide facility for the authorised representative of the County Council to carry out the critical inspections and tests detailed below:-

Critical Inspections/Tests			
Inspection or Test	Essential	Frequency	Date passed by LCC Authorised Representative
Review dip measurements for laying course thickness	Yes	One sample prior to use	
Verification of 2- 4mm infill grit material source	Yes	One sample prior to use	
Verification of 6 – 8mm laying course grit material source	Yes	One sample prior to use	
Ensure road is power washed and mechanically swept prior to drilling binder course infiltration holes	Yes	All lengths	
Inspect damaged kerbing for replacement	No	As required (all lengths)	
Inspection of cored infiltration holes in binder course e.g. spacing intervals, depth and check for contamination.	No	As required (all lengths)	



<b>Critical Inspections/Tests</b>			
<b>Inspection or Test</b>	<b>Essential</b>	<b>Frequency</b>	<b>Date passed by LCC Authorised Representative</b>
Sweep clean area to remove any contamination from drilling.	No	As required (all lengths)	
Inspection of backfill of infiltration holes – to be completed immediately after drilling to prevent contamination	No	As required (all lengths)	
Inspection of 6 – 8mm laying course – verification of depth (+ 10mm)	Yes	All lengths	
Check correct block dimensions and paving laying pattern	Yes	All lengths	
Inspection of cut blocks to be no less than 1/3 size of block.	Yes	All lengths	
Inspection of jointing grit, ensuring joints are filled to the top of the block	Yes	All lengths	
Inspection of block paving for ponding or irregularities	Yes	All lengths	
Inspection of any surface contamination in the block joints	Yes	All lengths	

Should the nominated representative of the developer fail to notify, inform or allow facility for the authorised representative of the County Council to carry out the above Critical Inspections and Tests at the correct time, then the County Council will require retrospective testing, to be determined by the authorised representative, to be carried out, at the developer's expense, which will include the following as a minimum:-

<b>Retrospective Inspections/Tests</b>		
<b>Inspection or Test</b>	<b>Essential</b>	<b>Frequency</b>
Retrospective testing is not feasible on this stage of pervious pavement construction.	NA	NA

**To achieve compliance and future adoption, the Developer must remove all current construction material to allow full inspection of the core drilling perforated binder course, to allow specified inspections and testing to take place in accordance with the Section 38 Agreement.**

**CERTIFICATION OF DEVELOPMENT ROAD CONSTRUCTION  
KEY STAGE S2 – PERMEABLE PAVING**

This is to certify that the key construction stage of PERMEABLE PAVING been satisfactorily notified and completed by:-

<b>General Information</b>	
<b>Development</b>	
<b>Developer</b>	

Development and that the key inspections and the key tests, above, have been successfully completed.

<b>Authorised representative of the County Council on behalf of the Executive Director for Place</b>
Signed:
Date:
<b>Lincolnshire County Council Technical Manager</b>
Counter Signed:
Date:

**Notwithstanding the above, the responsibility for all works and supervision on Development Roads lies with the developer. It is totally his responsibility to ensure and achieve compliance with the specification. Inspections and testing carried out by Lincolnshire County Council and this certification do not absolve the developer from this responsibility in any way.**

**DEVELOPMENT ROAD CONSTRUCTION CERTIFICATE  
KEY STAGE S3 – SWALES & FILTER STRIPS**

In accordance with the Section 38 Agreement for the development known as:-

General Information	
<b>Development</b>	
<b>Developer</b>	

The developer is required to obtain from the County Council, as Highway Authority, certification that the swales and filter strip works on this development have been carried out in accordance with the specification and agreed drawings and inspected and tested by an authorised representative of the County Council at the correct time.

In order to meet the above requirements, the nominated person named in accordance with the Section 38 Agreement as being responsible for managing construction and quality for the developer, in addition to ensuring compliance with this specification, shall notify in good time (**a minimum of five working days' notice**) and provide facility for the authorised representative of the County Council to carry out the critical inspections and tests detailed below:-

Information Required
----------------------

- Site Investigation Report
- Brownfield or Greenfield Site Classification
- Contamination Risk Assessment
- Determine existing ground water table depth

Critical Inspections/Tests			
Inspection or Test	Essential	Frequency	Date passed by LCC Authorised Representative
Verification of approved geotextile	Yes	All lengths	
Verification of Type B filter material	Yes	All lengths	
Confirm all services are located within service corridors	Yes	All lengths	
Verification of topsoil grade	Yes	All lengths	
Removal of existing vegetation/topsoil	Yes	All lengths	
Inspection of formation and levels	Yes	All lengths	
Check for made up ground and agree remedial action	Yes	All lengths	

<b>Critical Inspections/Tests</b>			
<b>Inspection or Test</b>	<b>Essential</b>	<b>Frequency</b>	<b>Date passed by LCC Authorised Representative</b>
Check swale / filter strip dimension / profile on site	Yes	All lengths	
Check dimensions of any under drain	Yes	All lengths	
Check correct erosion & scour protection on outlet pipes	Yes	As required	
Inspection of pipework, including bedding material and backfill and CCTV survey carried out	Yes	All lengths	
Laying and lapping of geotextile	Yes	All lengths	
Check 25mm kerb up stand to swale run off area.	Yes	All lengths	
Check top soil depth	Yes	All lengths	
Check sub-base depth & width in run off area	Yes	All lengths	
Verification of correct grass seed or turf species.	Yes	All lengths	
Inspect root protection systems for any tree planting	Yes	As required	
Verify correct tree species	Yes	As required	

Should the nominated representative of the developer fail to notify, inform or allow facility for the authorised representative of the County Council to carry out the above Critical Inspections and Tests at the correct time, then the County Council will require retrospective testing, to be determined by the authorised representative, to be carried out, at the developer's expense, which will include the following as a minimum:-

<b>Retrospective Inspections/Tests</b>		
<b>Inspection or Test</b>	<b>Essential</b>	<b>Frequency</b>
Verification of approved materials source (including confirmation of non-frost susceptibility) and verification of backfill materials - may require sample analysis	Yes	One per 100m (minimum two per site)
Confirmation that contamination is not a problem and review past uses	Yes	All lengths
CCTV survey of pipelines	No	As required (all lengths)
Confirm type & location of geotextile	Yes	All lengths
Confirm location and depth of sub-base in run off areas	Yes	As lengths
Verification of correct kerb face	Yes	All lengths
Level and profile survey of swales and strips	Yes	As required

### **Payment by the Developer for Failure to Achieve Certification of the Key Stage of Construction of SWALES & FILTER STRIPS**

In addition and irrespective of any retrospective testing or the outcome of such tests, should the Developer fail to obtain the relevant Certification for Swales & Filter Strips on this development or proceed without the consent of the Executive Director for Environment & Economy (or persons authorised by him), then the Council will require the Developer to pay a sum to the Council to cover possible future risk to the Authority associated with the lack of inspection and/or testing at

the correct stage. This will be calculated as 10% of the overall replacement cost of the Swale & Filter Strip, discounted over a 40 year period, as determined by the County Council.

**The alternative course of action to the above is for the Developer to remove all works and materials down to the lowest stage of construction which has an approval certificate to allow the specified inspections and testing to take place in accordance with the Section 38 Agreement.**

**CERTIFICATION OF DEVELOPMENT ROAD CONSTRUCTION  
KEY STAGE S3 – SWALES & FILTER STRIPS**

This is to certify that the key construction stage of SWALES & FILTER STRIPS has been satisfactorily notified and completed by:-

General Information	
<b>Development</b>	
<b>Developer</b>	

Development and that the key inspections and the key tests, above, have been successfully completed.

Authorized representative of the County Council on behalf of the Executive Director for Place
Signed:   
Date:   
Lincolnshire County Council Technical Manager
Counter Signed:   
Date:   

**Notwithstanding the above, the responsibility for all works and supervision on Development Roads lies with the developer. It is totally his responsibility to ensure and achieve compliance with the specification. Inspections and testing carried out by Lincolnshire County Council and this certification do not absolve the developer from this responsibility in any way.**

## NOTIFICATION OF FAILURE TO OBTAIN CERTIFICATION OF DEVELOPMENT ROAD CONSTRUCTION

### KEY STAGE S3 – SWALES & FILTER STRIPS

General Information	
<b>Development</b>	
<b>Developer</b>	

You are hereby informed that the key construction stage of Swales & Filter Strips was not notified by yourselves and inspected and tested wholly in accordance with the specification and as required by the Section 38 Agreement and as you have now commenced a subsequent stage of construction the following retrospective testing will be required:-

Retrospective Inspections/Tests		
Inspection or Test	Essential	Frequency
Verification of approved materials source (including confirmation of non-frost susceptibility) and verification of backfill materials - may require sample analysis	Yes	One per 100m (minimum two per site)
Confirmation that contamination is not a problem and review past uses	Yes	All lengths
CCTV survey of pipelines	No	As required (all lengths)
Confirm type & location of geotextile	Yes	All lengths
Confirm location and depth of sub-base in run off areas	Yes	As lengths
Verification of correct kerb face	Yes	All lengths
Level and profile survey of swales and strips	Yes	As required

Please inform the authorized representative of the county Council below, when the above tests are to be carried out and by whom. NB only tests carried out by a UKAS accredited laboratory or organization will be acceptable.

### Payment by the Developer for Failure to Achieve Certification of the Key Stage of Construction of SWALES & FILTER STRIPS

In addition, and irrespective of any retrospective testing or the outcome of such tests, you are informed that a letter will be sent to \_\_\_\_\_ informing of the County Council's requirement for you to pay a sum to the County Council to cover possible future risk to the authority associated with the lack of inspection and testing at this stage. This will be calculated as 10% of the overall replacement cost of the Swale and Filter Strip, discounted over a 40 year period, as determined by the County Council.

**The alternative course of action to the above is for the Developer to remove all works and materials down to the lowest stage of construction which has an approval certificate to allow the specified inspections and testing to take place in accordance with the Section**

**38 Agreement.**

**NOTIFICATION OF FAILURE TO OBTAIN CERTIFICATION OF DEVELOPMENT ROAD  
CONSTRUCTION**

**KEY STAGE S3 – SWALES & FILTER STRIPS**

<b>Authorised representative of the County Council on behalf of the Executive Director for Place</b>
Signed:
Date:
<b>Lincolnshire County Council Technical Manager</b>
Counter Signed:
Date:



**NOTIFICATION OF FAILURE TO OBTAIN CERTIFICATION  
FOR A DEVELOPMENT ROAD FOR SWALE & FILTER STRIP S3**

You are hereby informed that the Swale and or Filter strip

Developers Name	
Phase	
Site location	

was not notified by yourselves and inspected and tested wholly in accordance with the specification and as required by the Section 38 Agreement, and as you have now commenced a subsequent stage of construction, the following retrospective testing will be required:-

Retrospective Tests/Inspections

<b>Inspection or Test</b>	<b>Essential</b>	<b>Frequency</b>
Verification of approved materials source (including confirmation of non-frost susceptibility) and verification of backfill materials - may require sample analysis	√	1/100m min 2/site
Confirmation that contamination is not a problem and review past uses	√	All lengths
CCTV survey of pipelines	√	As required
Verification of correct geotextile, laying & lapping methods	√	All lengths
Confirm material source, location and depth of subbase in overrun areas	√	As required
Verify correct erosion and scour protection on outfall	√	As required
Verification of correct kerb face and upstand	√	All lengths
Level and profile survey of swales filter strips	√	As required

Please inform the authorized representative of the county Council below, when the above tests are to be carried out and by whom. NB only tests carried out by a UKAS accredited laboratory or organization will be acceptable.

**Payment by Developer for failure to Achieve Certification for Swale and Filter Strip -S3**

In addition, and irrespective of any retrospective testing or the outcome of such tests, you are informed that a letter will be sent to .....

confirming the County Council's requirement for you to pay a sum to the County Council to cover possible future risk to the authority associated with the lack of inspection and testing at this stage. This will be calculated as 10% of the overall replacement cost of the Swale and Filter Strip, discounted over a 40 year period, as determined by the County Council.

The alternative course of action to the above is for the Developer to remove all works and materials down to the lowest stage of construction which has an approval certificate to allow the specified inspections and testing to take place in accordance with the Section 38 Agreement.

**NOTIFICATION OF FAILURE TO OBTAIN CERTIFICATION  
FOR A DEVELOPMENT ROAD FOR SWALE & FILTER STRIP – S3**

Signed ..... Authorised representative of the County Council  
on behalf of the Executive Director for  
Environment & Economy

Date .....

Counter Signed ..... Lincolnshire County Council  
Technical Manager – Development

Date .....

**DEVELOPMENT ROAD CONSTRUCTION CERTIFICATE**  
**KEY STAGE T1 – DRAINAGE**

In accordance with the Section 38 Agreement for the development known as:-

General Information	
<b>Development</b>	
<b>Developer</b>	

The developer is required to obtain from the County Council, as Highway Authority, certification that the DRAINAGE works on this development have been carried out in accordance with the specification and agreed drawings and inspected and tested by an authorised representative of the County Council at the correct time.

In order to meet the above requirements, the nominated person named in accordance with the Section 38 Agreement as being responsible for managing construction and quality for the developer, in addition to ensuring compliance with this specification, shall notify in good time (**a minimum of five working days' notice**) and provide facility for the authorised representative of the County Council to carry out the critical inspections and tests detailed below:-

Critical Inspections/Tests			
Inspection or Test	Essential	Frequency	Date passed by LCC Authorised Representative
Verification of material sources for pipes, PCC units, covers/ frames, bedding and backfill material	Yes	All lengths	
Inspection of excavation and pipe bed	Yes	All lengths	
Inspections of line and level of laid pipes	Yes	All lengths	
Inspection of backfill and compaction (including on pipelines to be adopted by water company under S104 Agreement)	Yes	All lengths	

<b>Critical Inspections/Tests</b>			
<b>Inspection or Test</b>	<b>Essential</b>	<b>Frequency</b>	<b>Date passed by LCC Authorised Representative</b>
Air tests on pipelines (Water tests may be required if air test not satisfactory).	Yes	Each length between manholes	

Should the nominated representative of the developer fail to notify, inform or allow facility for the authorised representative of the County Council to carry out the above Critical Inspections and Tests at the correct time, then the County Council will require retrospective testing, to be determined by the authorised representative, to be carried out, at the developer's expense, which will include the following as a minimum:-

<b>Retrospective Inspections/Tests</b>		
<b>Inspection or Test</b>	<b>Essential</b>	<b>Frequency</b>
Detailed investigation of backfill suitability and compaction	Yes	One per 100m (minimum three per site)
Verification of material sources for pipes PCC units, covers/frames, bedding and backfill materials	Yes	All lengths
CCTV survey of pipelines	Yes	All lengths
Air tests on pipelines (Water tests may be required if air test not satisfactory)	Yes	Each length between manholes
Level survey	Yes	All lengths

**Payment by the Developer for Failure to Achieve Certification of the Key Stage of Construction of DRAINAGE**

In addition and irrespective of any retrospective testing or the outcome of such tests, should the Developer fail to obtain the relevant certificate for the key stage of DRAINAGE Works on this development or proceed without the consent of the Executive Director for Place (or persons authorised by him), then the Council will require the Developer to pay a sum to the Council to cover possible future risk to the Authority associated with the lack of inspection and/or testing at the correct stage. This will be calculated as 10% of the estimated cost of the drainage works, discounted over a 120 year period, plus 10% of the estimated cost of the carriageway sub-base binder course and surface course, discounted over a 40 year period, as determined by the County Council.

**The alternative course of action to the above is for the Developer to remove all works and materials down to the lowest stage of construction which has an approval certificate to**

**allow the specified inspections and testing to take place in accordance with the Section 38 Agreement.**

**CERTIFICATION OF DEVELOPMENT ROAD CONSTRUCTION**

**KEY STAGE T1 - DRAINAGE**

This is to certify that the key construction stage of DRAINAGE has been satisfactorily notified and completed by:-

General Information	
<b>Development</b>	
<b>Developer</b>	

Development and that the key inspections and the key tests, above, have been successfully completed.

Authorized representative of the County Council on behalf of the Executive Director for Place
Signed:
Date:
Lincolnshire County Council Technical Manager – Development Management
Counter Signed:
Date:

**Notwithstanding the above, the responsibility for all works and supervision on Development Roads lies with the developer. It is totally his responsibility to ensure and**

**achieve compliance with the specification. Inspections and testing carried out by Lincolnshire County Council and this certification do not absolve the developer from this responsibility in any way.**

**NOTIFICATION OF FAILURE TO OBTAIN CERTIFICATION OF DEVELOPMENT ROAD  
CONSTRUCTION**

**KEY STAGE T1 - DRAINAGE**

<b>General Information</b>	
<b>Development</b>	
<b>Developer</b>	

You are hereby informed that the key construction stage of DRAINAGE was not notified by yourselves and inspected and tested wholly in accordance with the specification and as required by the Section 38 Agreement and as you have now commenced a subsequent stage of construction the following retrospective testing will be required:-

<b>Retrospective Inspections/Tests</b>		
<b>Inspection or Test</b>	<b>Essential</b>	<b>Frequency</b>
Detailed investigation of backfill suitability and compaction	Yes	One per 100m (minimum three per site)
Verification of material sources for pipes PCC units, covers/frames, bedding and backfill materials	Yes	All lengths
CCTV survey of pipelines	Yes	All lengths
Air tests on pipelines (Water tests may be required if air test not satisfactory)	Yes	Each length between manholes
Level survey	Yes	All lengths

Please inform the authorized representative of the county Council below, when the above tests are to be carried out and by whom. NB only tests carried out by a UKAS accredited laboratory or organization will be acceptable.

**Payment by the Developer for Failure to Achieve Certification of the  
Key Stage of Construction of DRAINAGE**

In addition, and irrespective of any retrospective testing or the outcome of such tests, you are informed that a letter will be sent to \_\_\_\_\_ informing of the County Council's requirement for you to pay a sum to the County Council to cover possible future risk to the authority associated with the lack of inspection and testing at this stage. This will be calculated as 10% of the estimated



cost of the drainage works, discounted over a 120 year period, plus 10% of the estimated cost of the carriageway sub-base, binder course and surface course, discounted over a 40 year period, as determined by the County Council.

**The alternative course of action to the above is for the Developer to remove all works and materials down to the lowest stage of construction which has an approval certificate to allow the specified inspections and testing to take place in accordance with the Section 38 Agreement.**

**NOTIFICATION OF FAILURE TO OBTAIN CERTIFICATION OF DEVELOPMENT ROAD  
CONSTRUCTION**

**KEY STAGE T1 - DRAINAGE**

<b>Authorised representative of the County Council on behalf of the Executive Director for Place</b>
Signed:  
Date:  
<b>Lincolnshire County Council Technical Manager – Development Management</b>
Counter Signed:  
Date:  

**NOTIFICATION OF FAILURE TO OBTAIN CERTIFICATION OF DEVELOPMENT ROAD  
CONSTRUCTION**

**KEY STAGE T2 – SITE INVESTIGATION / FORMATION / EARTHWORKS / GEOTEXTILE**

<b>General Information</b>	
<b>Development</b>	
<b>Developer</b>	

You are hereby informed that the key construction stage of SITE INVESTIGATION / FORMATION / EARTHWORKS / GEOTEXTILE was not notified by yourselves and inspected and tested wholly in accordance with the specification and as required by the Section 38 Agreement and as you have now commenced a subsequent stage of construction the following retrospective testing will be required:-

<b>Retrospective Inspections/Tests</b>		
<b>Inspection or Test</b>	<b>Essential</b>	<b>Frequency</b>
Verification of formation levels	Yes	All lengths
Verification of material source for geotextiles	Yes	When used
Verification of material sources of capping inset	Yes	When used
Geology for the site	Yes	All lengths
Verification of sub-grade design CBR	Yes	All lengths
Review of past uses	Yes	All lengths
Confirmation that contamination is not a problem	Yes	All lengths

Please inform the authorized representative of the county Council below, when the above tests are to be carried out and by whom. NB only tests carried out by a UKAS accredited laboratory or organization will be acceptable.

**Payment by the Developer for Failure to Achieve Certification of the  
Key Stage of Construction of SITE INVESTIGATION / FORMATION / EARTHWORKS /  
GEOTEXTILE**

In addition, and irrespective of any retrospective testing or the outcome of such tests, you are informed that a letter will be sent to \_\_\_\_\_ informing of the County Council's requirement for you to pay a sum to the County Council to cover possible future risk to the authority associated with the lack of inspection and testing at the correct stage. This will be calculated as 10% of the overall construction works less the cost of drainage (provided that this has been previously certified) discounted over a 40 year period, as determined by the County Council.

**The alternative course of action to the above is for the Developer to remove all works and materials down to the lowest stage of construction which has an approval certificate to allow the specified inspections and testing to take place in accordance with the Section 38 Agreement.**

**NOTIFICATION OF FAILURE TO OBTAIN CERTIFICATION OF DEVELOPMENT ROAD  
CONSTRUCTION**

**KEY STAGE T2 – SITE INVESTIGATION / FORMATION / EARTHWORKS / GEOTEXTILE**

<b>Authorised representative of the County Council on behalf of the Executive Director for Place</b>
Signed:   
Date:   
<b>Lincolnshire County Council Technical Manager</b>
Counter Signed:   
Date:   

**NOTIFICATION OF FAILURE TO OBTAIN CERTIFICATION FOR A DEVELOPMENT KEY CONSTRUCTION STAGE**

**KEY STAGE T2 – SITE INVESTIGATION / FORMATION / EARTHWORKS / GEOTEXTILES**

You are hereby informed that the key construction stage of Site Investigation / Formation / Earthworks / Geotextiles at :-

<b>General Information</b>	
<b>Developers Name</b>	
<b>Phase</b>	
<b>Site location</b>	

was not notified by yourselves and inspected and tested wholly in accordance with the specification and as required by the Section 38 Agreement, and as you have now commenced a subsequent stage of construction, the following retrospective testing will be required:-

Retrospective Tests/Inspections

Inspection or Test	Essential	Frequency
Verification of formation levels	√	All lengths
Verification of material source for geotextiles	√	When used
Geology for the site	√	All lengths
Verification of sub-grade design CBR	√	All lengths
Review of past uses	√	All lengths
Confirmation that contamination is not a problem	√	All lengths
Verification of material sources of capping	√	When used

Please inform the authorized representative of the County Council below, when the above tests are to be carried out and by whom. NB only tests carried out by a UKAS accredited Laboratory or organization will be acceptable.

**Payment by the Developer for Failure to Achieve Certification of the Key Stage of Construction of Site Investigation Formation / Earthworks / Geotextile**

In addition, and irrespective of any retrospective testing or the outcome of such tests, you are informed that a letter will be sent to .....

informing

of the County Council's requirement for you to pay a sum to the County Council to cover possible future risk to the authority associated with the lack of inspection and testing at the correct stage. This will be calculated as 10% of the overall construction works less the cost of drainage (provided that this has been previously certified) discounted over a 40 year period, as

determined by the County Council.

**The alternative course of action to the above is for the Developer to remove all works and materials down to the lowest stage of construction which has an approval certificate to allow the specified inspections and testing to take place in accordance with the Section 38 Agreement.**

**NOTIFICATION OF FAILURE TO OBTAIN CERTIFICATION FOR A DEVELOPMENT KEY  
CONSTRUCTION STAGE**

**KEY STAGE T2 – SITE INVESTIGATION / FORMATION / EARTHWORKS / GEOTEXTILES**

Signed .....

Authorised representative of the County  
Council on behalf of the Executive  
Director for Environment and Economy

Date .....

Counter Signed .....

Lincolnshire County Council  
Technical Manager – Development

Date .....

## DEVELOPMENT ROAD CONSTRUCTION CERTIFICATE KEY STAGE T3 – CARRIAGEWAY SUB-BASE

In accordance with the Section 38 Agreement for the development known as:-

General Information	
<b>Development</b>	
<b>Developer</b>	

The developer is required to obtain from the County Council, as Highway Authority, certification that the CARRIAGEWAY SUB-BASE works on this development have been carried out in accordance with the specification and agreed drawings and inspected and tested by an authorised representative of the County Council at the correct time.

In order to meet the above requirements, the nominated person named in accordance with the Section 38 Agreement as being responsible for managing construction and quality for the developer, in addition to ensuring compliance with this specification, shall notify in good time (**a minimum of five working days' notice**) and provide facility for the authorised representative of the County Council to carry out the critical inspections and tests detailed below:-

Critical Inspections/Tests			
Inspection or Test	Essential	Frequency	Date passed by LCC Authorised Representative
Verification of approved material source (including confirmation of non-frost susceptibility)	Yes	All sources	
Bulk Sample Testing	No	As required (one per 150 tonne)	
Check depth of material	Yes	One per 100 tonne (or part thereof)	
Visual Inspection of completed sub-base	Yes	All lengths	
Plate bearing tests to assess compaction	Yes	One per 100m (minimum two per site)	

Should the nominated representative of the developer fail to notify, inform or allow facility for the authorised representative of the County Council to carry out the above Critical Inspections and Tests at the correct time, then the County Council will require retrospective testing, to be determined by the authorised representative, to be carried out, at the developer's expense, which will include the following as a minimum:-

Retrospective Inspections/Tests		
Inspection or Test	Essential	Frequency
Verification of approved materials source (including confirmation of non-frost susceptibility), may require sample analysis	Yes	One per 100m (minimum two per site)



<b>Retrospective Inspections/Tests</b>		
<b>Inspection or Test</b>	<b>Essential</b>	<b>Frequency</b>
Verification of depth and CBR values (through trial pits)	Yes	One per 100m (minimum two per site)

**Payment by the Developer for Failure to Achieve Certification of the  
Key Stage of Construction of CARRIAGEWAY SUB BASE**

In addition and irrespective of any retrospective testing or the outcome of such tests, should the Developer fail to obtain the relevant certificate for the key stage of CARRIAGEWAY SUB-BASE works on this development or proceed without the consent of the Executive Director for Place (or persons authorised by him), then the Council will require the Developer to pay a sum to the Council to cover possible future risk to the Authority associated with the lack of inspection and/or testing at the correct stage. This will be calculated as 10% of the replacement costs of the carriageway sub-base, binder course and surface course layers where applicable, discounted over a 40 year period, as determined by the County Council.

**The alternative course of action to the above is for the Developer to remove all works and materials down to the lowest stage of construction which has an approval certificate to allow the specified inspections and testing to take place in accordance with the Section 38 Agreement.**

## CERTIFICATION OF DEVELOPMENT ROAD CONSTRUCTION

### KEY STAGE T3 – CARRIAGEWAY SUB-BASE

This is to certify that the key construction stage of CARRIAGEWAY SUB-BASE has been satisfactorily notified and completed by:-

General Information	
<b>Development</b>	
<b>Developer</b>	

Development and that the key inspections and the key tests, above, have been successfully completed.

Authorized representative of the County Council on behalf of the Executive Director for Place	
Signed:	
Date:	
Lincolnshire County Council Technical Manager	
Counter Signed:	
Date:	

**Notwithstanding the above, the responsibility for all works and supervision on Development Roads lies with the developer. It is totally his responsibility to ensure and achieve compliance with the specification. Inspections and testing carried out by Lincolnshire County Council and this certification do not absolve the developer from this responsibility in any way.**

**NOTIFICATION OF FAILURE TO OBTAIN CERTIFICATION OF DEVELOPMENT ROAD  
CONSTRUCTION**

**KEY STAGE T3 – CARRIAGEWAY SUB-BASE**

<b>General Information</b>	
<b>Development</b>	
<b>Developer</b>	

You are hereby informed that the key construction stage of CARRIAGEWAY SUB-BASE was not notified by yourselves and inspected and tested wholly in accordance with the specification and as required by the Section 38 Agreement and as you have now commenced a subsequent stage of construction the following retrospective testing will be required:-

<b>Retrospective Inspections/Tests</b>		
<b>Inspection or Test</b>	<b>Essential</b>	<b>Frequency</b>
Verification of approved materials source (including confirmation of non-frost susceptibility), may require sample analysis	Yes	One per 100m (minimum two per site)
Verification of depth and CBR values (through trial pits)	Yes	One per 100m (minimum two per site)

Please inform the authorized representative of the county Council below, when the above tests are to be carried out and by whom. NB only tests carried out by a UKAS accredited laboratory or organization will be acceptable.

**Payment by the Developer for Failure to Achieve Certification of the  
Key Stage of Construction of CARRIAGEWAY SUB BASE**

In addition, and irrespective of any retrospective testing or the outcome of such tests, you are informed that a letter will be sent to \_\_\_\_\_ informing of the County Council's requirement for you to pay a sum to the County Council to cover possible future risk to the authority associated with the lack of inspection and testing at the correct stage. This will be calculated as 10% of the replacement costs of the carriageway sub-base, binder course and surface course layers where applicable, discounted over a 40 year period, as determined by the County Council.

**The alternative course of action to the above is for the Developer to remove all works and materials down to the lowest stage of construction which has an approval certificate to allow the specified inspections and testing to take place in accordance with the Section 38 Agreement.**

**NOTIFICATION OF FAILURE TO OBTAIN CERTIFICATION OF DEVELOPMENT ROAD  
CONSTRUCTION**

**KEY STAGE T3 – CARRIAGEWAY SUB-BASE**

<b>Authorised representative of the County Council on behalf of the Executive Director for Place</b>
Signed:  
Date:  
<b>Lincolnshire County Council Technical Manager</b>
Counter Signed:  
Date:  

**CERTIFICATION OF DEVELOPMENT ROAD CONSTRUCTION**

**KEY STAGE T3 – CARRIAGEWAY SUB-BASE**

This is to certify that the key construction stage of CARRIAGEWAY SUB-BASE has been satisfactorily notified and completed by:-

<b>General Information</b>	
<b>Development</b>	
<b>Developer</b>	

Development and that the key inspections and the key tests, above, have been successfully completed.

<b>Authorised representative of the County Council on behalf of the Executive Director for Place</b>	
Signed:	
Date:	
<b>Lincolnshire County Council Technical Manager</b>	
Counter Signed:	
Date:	

Notwithstanding the above, the responsibility for all works and supervision on Development Roads lies with the developer. It is totally his responsibility to ensure and achieve compliance with the specification. Inspections and testing carried out by Lincolnshire County Council and this certification do not absolve the developer from this responsibility in any way.

**NOTIFICATION OF FAILURE TO OBTAIN CERTIFICATION OF DEVELOPMENT ROAD  
CONSTRUCTION**

**KEY STAGE T3 – CARRIAGEWAY SUB-BASE**

<b>General Information</b>	
<b>Development</b>	
<b>Developer</b>	

You are hereby informed that the key construction stage of CARRIAGEWAY SUB-BASE was not notified by yourselves and inspected and tested wholly in accordance with the specification and as required by the Section 38 Agreement and as you have now commenced a subsequent stage of construction the following retrospective testing will be required:-

<b>Retrospective Inspections/Tests</b>		
<b>Inspection or Test</b>	<b>Essential</b>	<b>Frequency</b>
Verification of approved materials source (including confirmation of non-frost susceptibility), may require sample analysis	Yes	One per 100m (minimum two per site)
Verification of depth and CBR values (through trial pits)	Yes	One per 100m (minimum two per site)

Please inform the authorized representative of the county Council below, when the above tests are to be carried out and by whom. NB only tests carried out by a UKAS accredited laboratory or organization will be acceptable.

**Payment by the Developer for Failure to Achieve Certification of the  
Key Stage of Construction of CARRIAGEWAY SUB BASE**

In addition, and irrespective of any retrospective testing or the outcome of such tests, you are informed that a letter will be sent to \_\_\_\_\_ informing of the County Council’s requirement for you to pay a sum to the County Council to cover possible future risk to the authority associated with the lack of inspection and testing at the correct stage. This will be calculated as 10% of the replacement costs of the carriageway sub-base, binder course and surface course layers where applicable, discounted over a 40 year period, as determined by the County Council.

**The alternative course of action to the above is for the Developer to remove all works and materials down to the lowest stage of construction which has an approval certificate to allow the specified inspections and testing to take place in accordance with the Section 38 Agreement.**

**NOTIFICATION OF FAILURE TO OBTAIN CERTIFICATION OF DEVELOPMENT ROAD  
CONSTRUCTION**

**KEY STAGE T3 – CARRIAGEWAY SUB-BASE**

<b>Authorised representative of the County Council on behalf of the Executive Director for Place</b>
Signed:
Date:
<b>Lincolnshire County Council Technical Manager</b>
Counter Signed:
Date:

**NOTIFICATION OF FAILURE TO OBTAIN CERTIFICATION FOR A DEVELOPMENT KEY CONSTRUCTION STAGE**

**KEY STAGE T3 – CARRIAGEWAY SUB-BASE**

You are hereby informed that the key construction stage of carriageway Sub-base at

<b>General Information</b>	
<b>Developers Name</b>	
<b>Phase</b>	
<b>Site location</b>	

was not notified by yourselves and inspected and tested wholly in accordance with the specification and as required by the Section 38 Agreement, and as you have now commenced a subsequent stage of construction, the following retrospective testing will be required:-

Retrospective Tests/Inspections

Inspection or Test	Essential	Frequency
Verification of approved materials source (including confirmation of non-frost susceptibility), may require sample analysis	√	1/100m min 2/site
Verification of depth and CBR values (through trial pits)	√	1/100m min 2/site

Please inform the authorized representative of the County Council below, when the above tests are to be carried out and by whom. NB only tests carried out by a UKAS accredited Laboratory or organization will be acceptable.

**Payment by the Developer for Failure to Achieve Certification of the Key Stage of Construction of Carriageway Sub-Base**

In addition, and irrespective of any retrospective testing or the outcome of such tests, you are informed that a letter will be sent to ..... informing of the County Council's requirement for you to pay a sum to the County Council to cover possible future risk to the authority associated with the lack of inspection and testing at the correct stage. This will be calculated as 10% of the replacement costs of the carriageway sub-base, binder course and surface course layers where applicable, discounted over a 40 year period, as determined by the County Council.

**The alternative course of action to the above is for the Developer to remove all works and materials down to the lowest stage of construction which has an approval certificate to allow the specified inspections and testing to take place in accordance with the Section 38 Agreement.**

Signed .....

Authorised representative of the County Council on behalf of the Executive Director for Environment and Economy

Date .....

Counter Signed .....

Lincolnshire County Council



Date .....

## DEVELOPMENT ROAD CONSTRUCTION CERTIFICATE KEY STAGE T4 – KERBING AND CHANNELLING

In accordance with the Section 38 Agreement for the development known as:-

General Information	
<b>Development</b>	
<b>Developer</b>	

The developer is required to obtain from the County Council, as Highway Authority, certification that the KERBING AND CHANNELLING works on this development have been carried out in accordance with the specification and agreed drawings and inspected and tested by an authorised representative of the County Council at the correct time.

In order to meet the above requirements, the nominated person named in accordance with the Section 38 Agreement as being responsible for managing construction and quality for the developer, in addition to ensuring compliance with this specification, shall notify in good time (**a minimum of five working days' notice**) and provide facility for the authorised representative of the County Council to carry out the critical inspections and tests detailed below:-

Critical Inspections/Tests			
Inspection or Test	Essential	Frequency	Date passed by LCC Authorised Representative
Inspection of kerb/channel races, including line and level and dimensions (Kerb race/bed to be laid separate to backing)	Yes	All lengths	
Binder course to be laid in two stages and thickened if kerbs to be installed at a later stage	Yes	Check in all cases	
Verification of correct concrete mix	No	As required	
Verification of kerbs/channels from approved source and correct types	No	As required	
Inspection of kerb lines and levels	Yes	All lengths	
Correct faces and up stands	Yes	All lengths	

Should the nominated representative of the developer fail to notify, inform or allow facility for the authorised representative of the County Council to carry out the above Critical Inspections and Tests at the correct time, then the County Council will require retrospective testing, to be determined by the authorised representative, to be carried out, at the developer's expense, which will include the following as a minimum:-

<b>Retrospective Inspections/Tests</b>		
<b>Inspection or Test</b>	<b>Essential</b>	<b>Frequency</b>
Trial holes to inspect races	No	As required
Verification of use of correct concrete mixes	Yes	All lengths
Verification of source of kerbs and channels	No	As required
Inspection of kerb lines and levels	Yes	All lengths
Level survey	No	As required

**Payment by the Developer for Failure to Achieve Certification of the  
Key Stage of Construction of KERBING AND CHANNELLING**

In addition and irrespective of any retrospective testing or the outcome of such tests, should the Developer fail to obtain the relevant certificate for the key stage of KERBING AND CHANNELLING works on this development or proceed without the consent of the Director for Place (or persons authorised by him), then the Council will require the Developer to pay a sum to the Council to cover possible future risk to the Authority associated with the lack of inspection and/or testing at the correct stage. This will be calculated as 10% of the replacement cost of kerbing/channelling including races, together with replacement costs of carriageway surface course and all footway construction, where applicable, discounted over a 40 year period, as determined by the County Council.

**The alternative course of action to the above is for the Developer to remove all works and materials down to the lowest stage of construction which has an approval certificate to allow the specified inspections and testing to take place in accordance with the Section 38 Agreement.**

**CERTIFICATION OF DEVELOPMENT ROAD CONSTRUCTION**  
**KEY STAGE T4 – KERBING AND CHANNELLING**

This is to certify that the key construction stage of KERBING AND CHANNELLING has been satisfactorily notified and completed by:-

General Information	
<b>Development</b>	
<b>Developer</b>	

Development and that the key inspections and the key tests, above, have been successfully completed.

<b>Authorised representative of the County Council on behalf of the Executive Director for Place</b>	
Signed:	
Date:	
<b>Lincolnshire County Council Technical Manager</b>	
Counter Signed:	
Date:	

**Notwithstanding the above, the responsibility for all works and supervision on Development Roads lies with the developer. It is totally his responsibility to ensure and achieve compliance with the specification. Inspections and testing carried out by Lincolnshire County Council and this certification do not absolve the developer from this responsibility in any way.**

**NOTIFICATION OF FAILURE TO OBTAIN CERTIFICATION OF DEVELOPMENT ROAD  
CONSTRUCTION**

**KEY STAGE T4 – KERBING AND CHANNELLING**

<b>General Information</b>	
<b>Development</b>	
<b>Developer</b>	

You are hereby informed that the key construction stage of KERBING AND CHANNELLING was not notified by yourselves and inspected and tested wholly in accordance with the specification and as required by the Section 38 Agreement and as you have now commenced a subsequent stage of construction the following retrospective testing will be required:-

<b>Retrospective Inspections/Tests</b>		
<b>Inspection or Test</b>	<b>Essential</b>	<b>Frequency</b>
Trial holes to inspect races	No	As required
Verification of use of correct concrete mixes	Yes	All lengths
Verification of source of kerbs and channels	No	As required
Inspection of kerb lines and levels	Yes	All lengths
Level survey	No	As required

Please inform the authorized representative of the county Council below, when the above tests are to be carried out and by whom. NB only tests carried out by a UKAS accredited laboratory or organization will be acceptable.

**Payment by the Developer for Failure to Achieve Certification of the  
Key Stage of Construction of KERBING AND CHANNELLING**

In addition, and irrespective of any retrospective testing or the outcome of such tests, you are informed that a letter will be sent to \_\_\_\_\_ informing of the County Council's requirement for you to pay a sum to the County Council to cover possible future risk to the authority associated with the lack of inspection and testing at this stage. This will be calculated as 10% of the replacement cost of kerbing/channelling including races, together with replacement costs of carriageway surface course and all footway construction, where applicable, discounted over a 40 year period, as determined by the County Council.

**The alternative course of action to the above is for the Developer to remove all works and materials down to the lowest stage of construction which has an approval certificate to allow the specified inspections and testing to take place in accordance with the Section 38 Agreement.**

**NOTIFICATION OF FAILURE TO OBTAIN CERTIFICATION OF DEVELOPMENT ROAD  
CONSTRUCTION**

**KEY STAGE T4 – KERBING AND CHANNELLING**

<b>Authorised representative of the County Council on behalf of the Executive Director for Place</b>
Signed:
Date:
<b>Lincolnshire County Council Technical Manager</b>
Counter Signed:
Date:

**DEVELOPMENT ROAD CONSTRUCTION CERTIFICATE**  
**KEY STAGE T5 – CARRIAGEWAY BINDER COURSE**

In accordance with the Section 38 Agreement for the development known as:-

General Information	
<b>Development</b>	
<b>Developer</b>	

The developer is required to obtain from the County Council, as Highway Authority, certification that the CARRIAGEWAY BINDER COURSE works on this development have been carried out in accordance with the specification and agreed drawings and inspected and tested by an authorised representative of the County Council at the correct time.

In order to meet the above requirements, the nominated person named in accordance with the Section 38 Agreement as being responsible for managing construction and quality for the developer, in addition to ensuring compliance with this specification, shall notify in good time (**a minimum of five working days' notice**) and provide facility for the authorised representative of the County Council to carry out the critical inspections and tests detailed below:-

Critical Inspections/Tests			
Inspection or Test	Essential	Frequency	Date passed by LCC Authorised Representative
Verification of approved material source and supply (check correct binder penetration)	Yes	All lengths	
Bulk sample testing	No	As required (one per 150 tonne)	
Inspection of top of binder course (potential drainage problems)	Yes	All lengths	
Cores to assess thickness, compaction and bond	Yes	One per paver lane per 100m (minimum three per site)	
Rolling Straight Edge tests	No	As required (all wheel paths)	

Should the nominated representative of the developer fail to notify, inform or allow facility for the authorised representative of the County Council to carry out the above Critical Inspections and Tests at the correct time, then the County Council will require retrospective testing, to be determined by the authorised representative, to be carried out, at the developer's expense, which will include the following as a minimum:-

**Retrospective Inspections/Tests**

Inspection or Test	Essential	Frequency
Verification of approved material source and supply (check correct binder penetration)	Yes	All sources
Material analysis	No	One per 150 tonne
Cores to assess thickness compaction and bond	Yes	One per paver lane per 100m (minimum three per site)
Level survey	No	As required

**Payment by the Developer for Failure to Achieve Certification of the Key Stage of Construction of CARRIAGEWAY BINDER COURSE**

In addition and irrespective of any retrospective testing or the outcome of such tests, should the Developer fail to obtain the relevant certificate for the key stage of CARRIAGEWAY BINDER COURSE works on this development or proceed without the consent of the Executive Director for Place (or persons authorised by him), then the Council will require the Developer to pay a sum to the Council to cover possible future risk to the Authority associated with the lack of inspection and/or testing at the correct stage. This will be calculated as 10% of the replacement cost of the carriageway binder course and carriageway surface course or block paving, discounted over a 40 year period, as determined by the County Council.

**The alternative course of action to the above is for the Developer to remove all works and materials down to the lowest stage of construction which has an approval certificate to allow the specified inspections and testing to take place in accordance with the Section 38 Agreement.**



**CERTIFICATION OF DEVELOPMENT ROAD CONSTRUCTION**

**KEY STAGE T5 – CARRIAGEWAY BINDER COURSE**

This is to certify that the key construction stage of CARRIAGEWAY BINDER COURSE has been satisfactorily notified and completed by:-

General Information	
<b>Development</b>	
<b>Developer</b>	

Development and that the key inspections and the key tests, above, have been successfully completed.

<b>Authorised representative of the County Council on behalf of the Executive Director for Place</b>	
Signed:	
Date:	
<b>Lincolnshire County Council Technical Manager</b>	
Counter Signed:	
Date:	

**Notwithstanding the above, the responsibility for all works and supervision on Development Roads lies with the developer. It is totally his responsibility to ensure and achieve compliance with the specification. Inspections and testing carried out by Lincolnshire County Council and this certification do not absolve the developer from this responsibility in any way.**

**NOTIFICATION OF FAILURE TO OBTAIN CERTIFICATION OF DEVELOPMENT ROAD  
CONSTRUCTION**

**KEY STAGE T5 – CARRIAGEWAY BINDER COURSE**

<b>General Information</b>	
<b>Development</b>	
<b>Developer</b>	

You are hereby informed that the key construction stage of CARRIAGEWAY BINDER COURSE was not notified by yourselves and inspected and tested wholly in accordance with the specification and as required by the Section 38 Agreement and as you have now commenced a subsequent stage of construction the following retrospective testing will be required:-

<b>Retrospective Inspections/Tests</b>		
<b>Inspection or Test</b>	<b>Essential</b>	<b>Frequency</b>
Verification of approved material source and supply (check correct binder penetration)	Yes	All sources
Material analysis	No	One per 150 tonne
Cores to assess thickness compaction and bond	Yes	One per paver lane per 100m (minimum three per site)
Level survey	No	As required

Please inform the authorized representative of the county Council below, when the above tests are to be carried out and by whom. NB only tests carried out by a UKAS accredited laboratory or organization will be acceptable.

**Payment by the Developer for Failure to Achieve Certification of the  
Key Stage of Construction of CARRIAGEWAY BINDER COURSE**

In addition, and irrespective of any retrospective testing or the outcome of such tests, you are informed that a letter will be sent to informing of the County Council's requirement for you to pay a sum to the County Council to cover possible future risk to the authority associated with the lack of inspection and testing at this correct stage. This will be calculated as 10% of the replacement cost of the carriageway binder course and carriageway surface course or block paving, discounted over a 40 year period, as determined by the County Council.

**The alternative course of action to the above is for the Developer to remove all works and materials down to the lowest stage of construction which has an approval certificate to allow the specified inspections and testing to take place in accordance with the Section 38 Agreement.**

**NOTIFICATION OF FAILURE TO OBTAIN CERTIFICATION OF DEVELOPMENT ROAD  
CONSTRUCTION**

**KEY STAGE T5 – CARRIAGEWAY BINDER COURSE**

<b>Authorised representative of the County Council on behalf of the Executive Director for Place</b>
Signed:
Date:
<b>Lincolnshire County Council Technical Manager</b>
Counter Signed:
Date:

## DEVELOPMENT ROAD CONSTRUCTION CERTIFICATE

### KEY STAGE T6 – FOOTWAYS AND EDGING

In accordance with the Section 38 Agreement for the development known as:-

General Information	
<b>Development</b>	
<b>Developer</b>	

The developer is required to obtain from the County Council, as Highway Authority, certification that the FOOTWAYS AND EDGING works on this development have been carried out in accordance with the specification and agreed drawings and inspected and tested by an authorised representative of the County Council at the correct time.

In order to meet the above requirements, the nominated person named in accordance with the Section 38 Agreement as being responsible for managing construction and quality for the developer, in addition to ensuring compliance with this specification, shall notify in good time (**a minimum of five working days' notice**) and provide facility for the authorised representative of the County Council to carry out the critical inspections and tests detailed below:-

Critical Inspections/Tests			
Inspection or Test	Essential	Frequency	Date passed by LCC Authorised Representative
Inspection of formation	Yes	All lengths	
Inspection of all backfilling and compaction of all pits, service trenches, redundant land drainage, etc. (with sub-base material)	Yes	All lengths	
Removal of vegetation/topsoil	Yes	All lengths	
Weed spray to formation	No	All lengths	
Verification of approved source for sub-base material (confirmation non-frost susceptibility)	Yes	All sources	
Check depth of sub-base	Yes	All lengths	
Inspection of edgings, including bed/backing and line and level (ensure line of edgings are dropped at vehicular crossings to prevent excessive gradients on footways) & all crossfalls	Yes	All lengths	
Verification of correct concrete type	No	As required	

<b>Critical Inspections/Tests</b>			
<b>Inspection or Test</b>	<b>Essential</b>	<b>Frequency</b>	<b>Date passed by LCC Authorised Representative</b>
Verification of edgings from approved source and correct type	No	As required	
Check for dropped kerbs and tactile crossing points at all junctions, ensure dropped channel kerbs are to be flush with finished surface (Not to exceed 6mm up stand) NOT 25mm UPSTAND	Yes	All locations	
Verification of approved material source and supply for binder course and surface courses	Yes	All lengths	
Bulk sample testing	No	As required (one per 150 tonne)	
Ensure sufficient depth is allowed following the laying of binder course to allow for 25mm of surface course	Yes	All lengths	
Cores to separately assess thickness, compaction and bond of binder and surface course layers	Yes	One per 100m (minimum three per site)	

Should the nominated representative of the developer fail to notify, inform or allow facility for the authorised representative of the County Council to carry out the above Critical Inspections and Tests at the correct time, then the County Council will require retrospective testing, to be determined by the authorised representative, to be carried out, at the developer's expense, which will include the following as a minimum:-

<b>Retrospective Inspections/Tests</b>		
<b>Inspection or Test</b>	<b>Essential</b>	<b>Frequency</b>
Verification of all approved material sources and supply	Yes	All materials
Trial holes to determine material thicknesses, depth and sub- base compaction	No	One per 100m (minimum three per site)
Materials analysis	No	One per 150 tonne
Cores to determine depth, compaction and bond of binder and surface course layers.	Yes	One per 100m (minimum three per site)
Level survey	No	As required

### **Payment by the Developer for Failure to Achieve Certification of the Key Stage of Construction of FOOTWAYS AND EDGING**

In addition and irrespective of any retrospective testing or the outcome of such tests, should the Developer fail to obtain the relevant certificate for the key stage of FOOTWAYS AND EDGING works on this development or proceed without the consent of the Executive Director for Place (or persons authorised by him), then the Council will require the Developer to pay a sum to the Council to cover possible future risk to the Authority associated with the lack of inspection and/or testing at the correct stage. This will be calculated as 10% of the replacement cost of the footways and edgings, discounted over a 40 year period, as determined by the County Council.

**The alternative course of action to the above is for the Developer to remove all works and materials down to the lowest stage of construction which has an approval certificate to allow the specified inspections and testing to take place in accordance with the Section 38 Agreement.**

## CERTIFICATION OF DEVELOPMENT ROAD CONSTRUCTION

### KEY STAGE T6 – FOOTWAYS AND EDGING

This is to certify that the key construction stage of FOOTWAYS AND EDGING has been satisfactorily notified and completed by:-

General Information	
Development	
Developer	

Development and that the key inspections and the key tests, above, have been successfully completed.

Authorised representative of the County Council on behalf of the Executive Director for Place
Signed:
Date:
Lincolnshire County Council Technical Manager
Counter Signed:
Date:

**Notwithstanding the above, the responsibility for all works and supervision on Development Roads lies with the developer. It is totally his responsibility to ensure and achieve compliance with the specification. Inspections and testing carried out by Lincolnshire County Council and this certification do not absolve the developer from this responsibility in any way.**

**NOTIFICATION OF FAILURE TO OBTAIN CERTIFICATION OF DEVELOPMENT ROAD  
CONSTRUCTION**

**KEY STAGE T6 – FOOTWAYS AND EDGING**

<b>General Information</b>	
<b>Development</b>	
<b>Developer</b>	

You are hereby informed that the key construction stage of FOOTWAYS AND EDGING was not notified by yourselves and inspected and tested wholly in accordance with the specification and as required by the Section 38 Agreement and as you have now commenced a subsequent stage of construction the following retrospective testing will be required:-

<b>Retrospective Inspections/Tests</b>		
<b>Inspection or Test</b>	<b>Essential</b>	<b>Frequency</b>
Verification of approved material source and supply (check correct binder penetration)	Yes	All sources
Material analysis	No	One per 150 tonne
Cores to assess thickness compaction and bond	Yes	One per paver lane per 100m (min three per site)
Level survey	No	As required

Please inform the authorized representative of the county Council below, when the above tests are to be carried out and by whom. NB only tests carried out by a UKAS accredited laboratory or organization will be acceptable.

**Payment by the Developer for Failure to Achieve Certification of the  
Key Stage of Construction of FOOTWAYS AND EDGING**

In addition, and irrespective of any retrospective testing or the outcome of such tests, you are informed that a letter will be sent to \_\_\_\_\_ informing of the County Council's requirement for you to pay a sum to the County Council to cover possible future risk to the authority associated with the lack of inspection and testing at this stage. This will be calculated as 10% of the replacement cost of the footways and edgings, discounted over a 40 year period, as determined by the County Council.

**The alternative course of action to the above is for the Developer to remove all works and materials down to the lowest stage of construction which has an approval certificate to allow the specified inspections and testing to take place in accordance with the Section 38 Agreement.**



**NOTIFICATION OF FAILURE TO OBTAIN CERTIFICATION OF DEVELOPMENT ROAD  
CONSTRUCTION**

**KEY STAGE T6 – FOOTWAYS AND EDGING**

<b>Authorised representative of the County Council on behalf of the Executive Director for Place</b>
Signed:
Date:
<b>Lincolnshire County Council Technical Manager</b>
Counter Signed:
Date:

**NOTIFICATION OF FAILURE TO OBTAIN CERTIFICATION FOR A DEVELOPMENT KEY CONSTRUCTION STAGE**

**KEY STAGE T6 – FOOTWAYS AND EDGINGS**

You are hereby informed that the key construction stage of Footways and Edging Works at :-

<b>General Information</b>	
<b>Developers Name</b>	
<b>Phase</b>	
<b>Site location</b>	

was not notified by yourselves and inspected and tested wholly in accordance with the specification and as required by the Section 38 Agreement, and as you have now commenced a subsequent stage of construction, the following retrospective testing will be required:-

Retrospective Tests/Inspections

Inspection or Test	Essential	Frequency
Verification of all approved material sources and supply	√	All materials
Trial holes to determine material thicknesses, depth and sub- base compaction		1/100 m min 3 per site
Materials analysis		1/150t
Cores to determine depth, compaction and bond	√	1/100 m min 3 per site
Level survey		As required

Please inform the authorised representative of the County Council below, when the above tests are to be carried out and by whom. NB only tests carried out by a UKAS accredited Laboratory or organization will be acceptable.

**Payment by the Developer for Failure to Achieve Certification of the Key Stage of Construction of Footways and Edgings**

In addition, and irrespective of any retrospective testing or the outcome of such tests, you are informed that a letter will be sent to

.....

informing of the

County Council’s requirement for you to pay a sum to the County Council to cover possible future risk to the authority associated with the lack of inspection and testing at this stage. This will be calculated as 10% of the replacement cost of the footways and edgings, discounted over a 40 year period, as determined by the County Council.

**The alternative course of action to the above is for the Developer to remove all works and materials down to the lowest stage of construction which has an approval certificate to allow the specified inspections and testing to take place in accordance with the Section 38 Agreement.**

Signed .....

Authorised representative of the County Council on behalf of the Executive Director for Environment and Economy

Date .....

## DEVELOPMENT ROAD CONSTRUCTION CERTIFICATE

### KEY STAGE T7 – BLOCK PAVED AREAS

In accordance with the Section 38 Agreement for the development known as:-

General Information	
<b>Development</b>	
<b>Developer</b>	

The developer is required to obtain from the County Council, as Highway Authority, certification that the BLOCK PAVED AREAS works on this development have been carried out in accordance with the specification and agreed drawings and inspected and tested by an authorised representative of the County Council at the correct time.

In order to meet the above requirements, the nominated person named in accordance with the Section 38 Agreement as being responsible for managing construction and quality for the developer, in addition to ensuring compliance with this specification, shall notify in good time (**a minimum of five working days' notice**) and provide facility for the authorised representative of the County Council to carry out the critical inspections and tests detailed below:-

Critical Inspections/Tests			
Inspection or Test	Essential	Frequency	Date passed by LCC Authorised Representative
Notification of approved material sources (e.g. blocks and bedding and jointing sand)	Yes	All lengths	
Inspect approved laying patterns (mortar infill not to be used)	Yes	All lengths	
Ensure sufficient edge restraints	Yes	All lengths	
Check correct thickness, colours and dimensions of blocks	Yes	All lengths	
Check correct type and dimensions of small element kerbing	Yes	All lengths	
Check correct kerb faces	Yes	All lengths	
Depth of bedding sand within tolerances	Yes	All lengths	
Inspect completed surface regularity (check for drainage problems and possible areas of ponding).	Yes	All lengths	

Should the nominated representative of the developer fail to notify, inform or allow facility for the authorised representative of the County Council to carry out the above Critical Inspections and Tests at the correct time, then the County Council will require retrospective testing, to be determined by the authorised representative, to be carried out, at the developer's expense, which will include the following as a minimum:-

<b>Retrospective Inspections/Tests</b>		
<b>Inspection or Test</b>	<b>Essential</b>	<b>Frequency</b>
Verification of approved material sources	Yes	All lengths
Inspect approved laying patterns	Yes	All lengths
Remove areas of block work to check depth of bedding sand within tolerances	No	As required
Inspect completed surface regularity (check for drainage problems and possible areas of ponding)	Yes	All lengths
Level survey	No	As required
Profile survey	No	As required

**Payment by the Developer for Failure to Achieve Certification of the  
Key Stage of Construction of BLOCK PAVED AREAS**

In addition and irrespective of any retrospective testing or the outcome of such tests, should the Developer fail to obtain the relevant certificate for the key stage of BLOCK PAVED AREAS works on this development or proceed without the consent of the Executive Director for Place (or persons authorised by him), then the Council will require the Developer to pay a sum to the Council to cover possible future risk to the Authority associated with the lack of inspection and/or testing at the correct stage. This will be calculated as 10% of the overall replacement cost of the block paving, discounted over a 40 year period, as determined by the County Council.

**The alternative course of action to the above is for the Developer to remove all works and materials down to the lowest stage of construction which has an approval certificate to allow the specified inspections and testing to take place in accordance with the Section 38 Agreement.**

**CERTIFICATION OF DEVELOPMENT ROAD CONSTRUCTION**

**KEY STAGE T7 – BLOCK PAVED AREAS**

This is to certify that the key construction stage of BLOCK PAVED AREAS has been satisfactorily notified and completed by:-

<b>General Information</b>	
<b>Development</b>	
<b>Developer</b>	

Development and that the key inspections and the key tests, above, have been successfully completed.

<b>Authorised representative of the County Council on behalf of the Executive Director for Place</b>	
Signed:	
Date:	
<b>Lincolnshire County Council Technical Manager</b>	
Counter Signed:	
Date:	

**Notwithstanding the above, the responsibility for all works and supervision on Development Roads lies with the developer. It is totally his responsibility to ensure and achieve compliance with the specification. Inspections and testing carried out by Lincolnshire County Council and this certification do not absolve the developer from this responsibility in any way.**

## NOTIFICATION OF FAILURE TO OBTAIN CERTIFICATION OF DEVELOPMENT ROAD CONSTRUCTION

### KEY STAGE T7 – BLOCK PAVED AREAS

General Information	
Development	
Developer	

You are hereby informed that the key construction stage of BLOCK PAVED AREAS was not notified by yourselves and inspected and tested wholly in accordance with the specification and as required by the Section 38 Agreement and as you have now commenced a subsequent stage of construction the following retrospective testing will be required:-

Retrospective Inspections/Tests		
Inspection or Test	Essential	Frequency
Verification of approved material sources	Yes	All lengths
Inspect approved laying patterns	No	All lengths
Remove areas of block work to check depth of bedding sand within tolerances	No	As required
Inspect completed surface regularity (check for drainage problems and possible areas of ponding)	Yes	All lengths
Level survey	No	As required
Profile survey	No	As required

Please inform the authorized representative of the county Council below, when the above tests are to be carried out and by whom. NB only tests carried out by a UKAS accredited laboratory or organization will be acceptable.

### Payment by the Developer for Failure to Achieve Certification of the Key Stage of Construction of BLOCK PAVED AREAS

In addition, and irrespective of any retrospective testing or the outcome of such tests, you are informed that a letter will be sent to \_\_\_\_\_ informing of the County Council's requirement for you to pay a sum to the County Council to cover possible future risk to the authority associated with the lack of inspection and testing at this stage. This will be calculated as 10% of the overall replacement cost of the block paving, discounted over a 40 year period, as determined by the County Council.

**The alternative course of action to the above is for the Developer to remove all works and materials down to the lowest stage of construction which has an approval certificate to allow the specified inspections and testing to take place in accordance with the Section 38 Agreement.**

**NOTIFICATION OF FAILURE TO OBTAIN CERTIFICATION OF DEVELOPMENT ROAD  
CONSTRUCTION**

**KEY STAGE T7 – BLOCK PAVED AREAS**

<b>Authorised representative of the County Council on behalf of the Executive Director for Place</b>
Signed:
Date:
<b>Lincolnshire County Council Technical Manager</b>
Counter Signed:
Date:

## DEVELOPMENT ROAD CONSTRUCTION CERTIFICATE

### KEY STAGE T8 – CARRIAGEWAY SURFACE COURSE

In accordance with the Section 38 Agreement for the development known as:-

General Information	
<b>Development</b>	
<b>Developer</b>	

The developer is required to obtain from the County Council, as Highway Authority, certification that the CARRIAGEWAY SURFACE COURSE works on this development have been carried out in accordance with the specification and agreed drawings and inspected and tested by an authorised representative of the County Council at the correct time.

In order to meet the above requirements, the nominated person named in accordance with the Section 38 Agreement as being responsible for managing construction and quality for the developer, in addition to ensuring compliance with this specification, shall notify in good time (**a minimum of five working days' notice**) and provide facility for the authorised representative of the County Council to carry out the critical inspections and tests detailed below:-

Critical Inspections/Tests			
Inspection or Test	Essential	Frequency	Date passed by LCC Authorised Representative
Surface of binder course clean and free of contamination	Yes	All lengths	
Verification of approved material source and supply (check PSV requirements and chipping source for HRA)	Yes	All sources	
Bulk Sample Testing – Coated Chippings	Yes	One per 20 tonne	
Bulk Sample Testing – HRA or Close Graded Surface Course	Yes	As required (one per 150 tonne)	
Texture depth testing for HRA or Thin Surfacing	Yes	All wheel paths	
Cores to assess thickness compaction and bond of all bound layers	Yes	One per paver lane per 100m (minimum three per site)	
Rolling straight edge tests	Yes	All wheel paths	
Inspect completed surface regularity (check for drainage problems and possible areas of ponding).	Yes	All lengths	

Should the nominated representative of the developer fail to notify, inform or allow facility for the



authorised representative of the County Council to carry out the above Critical Inspections and Tests at the correct time, then the County Council will require retrospective testing, to be determined by the authorised representative, to be carried out, at the developer's expense, which will include the following as a minimum:-

<b>Retrospective Inspections/Tests</b>		
<b>Inspection or Test</b>	<b>Essential</b>	<b>Frequency</b>
Verification of approved material source and supply (check correct binder penetration, PSV requirements and chipping source for HRA)	Yes	All lengths
Material analysis	No	One per 150 tonne
Cores to assess thickness compaction and bond of all bound layers	Yes	One per paver lane per 100m (minimum three per site)
Rolling straight edge tests	Yes	All wheel paths
Texture depth testing for HRA or Thin Surfacing	Yes	All wheel paths
White line testing	No	As required
Level survey	Yes	All lengths

#### **Payment by the Developer for Failure to Achieve Certification of the**

In addition and irrespective of any retrospective testing or the outcome of such tests, should the Developer fail to obtain the relevant certificate for the key stage of the CARRIAGEWAY SURFACE COURSE works on this development or proceed without the consent of the Executive Director for Place (or persons authorised by him), then the Council will require the Developer to pay a sum to the Council to cover possible future risk to the Authority associated with the lack of inspection and/or testing at the correct stage. This will be calculated as 10% of the replacement cost of the carriageway surface course, discounted over a 40 year period, as determined by the County Council.

**The alternative course of action to the above is for the Developer to remove all works and materials down to the lowest stage of construction which has an approval certificate to allow the specified inspections and testing to take place in accordance with the Section 38 Agreement.**

**CERTIFICATION OF DEVELOPMENT ROAD CONSTRUCTION**  
**KEY STAGE T8 – CARRIAGEWAY SURFACE COURSE**

This is to certify that the key construction stage of CARRIAGEWAY SURFACE COURSE has been satisfactorily notified and completed by:-

General Information	
<b>Development</b>	
<b>Developer</b>	

Development and that the key inspections and the key tests, above, have been successfully completed.

Authorized representative of the County Council on behalf of the Executive Director for Place	
Signed:	
Date:	
Lincolnshire County Council Technical Manager	
Counter Signed:	
Date:	

**Notwithstanding the above, the responsibility for all works and supervision on Development Roads lies with the developer. It is totally his responsibility to ensure and achieve compliance with the specification. Inspections and testing carried out by Lincolnshire County Council and this certification do not absolve the developer from this responsibility in any way.**

## NOTIFICATION OF FAILURE TO OBTAIN CERTIFICATION OF DEVELOPMENT ROAD CONSTRUCTION

### KEY STAGE T8 – CARRIAGEWAY SURFACE COURSE

General Information	
<b>Development</b>	
<b>Developer</b>	

You are hereby informed that the key construction stage of CARRIAGEWAY SURFACE COURSE was not notified by yourselves and inspected and tested wholly in accordance with the specification and as required by the Section 38 Agreement and as you have now commenced a subsequent stage of construction the following retrospective testing will be required:-

Retrospective Inspections/Tests		
Inspection or Test	Essential	Frequency
Verification of approved material source and supply (check correct binder penetration, PSV requirements and chipping source for HRA)	Yes	All lengths
Material analysis	No	One per 150 tonne
Cores to assess thickness compaction and bond of all bound layers	Yes	One per paver lane per 100m (minimum three per site)
Rolling straight edge tests	Yes	All wheel paths
Texture depth testing for HRA or Thin Surfacing	Yes	All wheel paths
White line testing	No	As required
Level survey	Yes	All lengths

Please inform the authorized representative of the county Council below, when the above tests are to be carried out and by whom. NB only tests carried out by a UKAS accredited laboratory or organization will be acceptable.

### Payment by the Developer for Failure to Achieve Certification of the Key Stage of Construction of CARRIAGEWAY SURFACE COURSE

In addition, and irrespective of any retrospective testing or the outcome of such tests, you are informed that a letter will be sent to \_\_\_\_\_ informing of the County Council's requirement for you to pay a sum to the County Council to cover possible future risk to the authority associated with the lack of inspection and testing at this correct stage. This will be calculated as 10% of the replacement cost of the carriageway surface course, discounted over a 40 year period, as determined by the County Council.

**The alternative course of action to the above is for the Developer to remove all works and materials down to the lowest stage of construction which has an approval certificate to allow the specified inspections and testing to take place in accordance with the Section 38 Agreement.**

**NOTIFICATION OF FAILURE TO OBTAIN CERTIFICATION OF DEVELOPMENT ROAD  
CONSTRUCTION**

**KEY STAGE T8 – CARRIAGEWAY SURFACE COURSE**

<b>Authorised representative of the County Council on behalf of the Executive Director for Place</b>
Signed:
Date:
<b>Lincolnshire County Council Technical Manager</b>
Counter Signed:
Date:

**DEVELOPMENT ROAD INSPECTION CERTIFICATE**  
**KEY STAGE T9 – PRE-MAINTENANCE PERIOD**

In accordance with the Section 38 Agreement for the development known as:-

<b>General Information</b>	
<b>Development</b>	
<b>Developer</b>	

In order for this development to be entered into the 12 months maintenance period in accordance with the Section 38 Agreement, a Pre-Maintenance period inspection must be undertaken between the person named in the S38 Agreement as being responsible for managing construction and quality for this developer and the authorised representative of the County Council.

<b>Areas for inspection</b>		
<b>Inspection</b>	<b>Summary Details</b>	<b>Date passed by LCC Authorised Representative</b>
Road and footway are correctly swept & cleaned		
Overall condition of all surfaces, ensuring there are no outstanding defects, temporary reinstatements or excavations		
Any damage to kerbs channels blocks or edgings		
Any weed growth to be treated		
Confirm no sediment build up in the permeable pavement, swales or filter strips		
Confirm pervious pavement is draining effectively, no settlement in levels & no block migration		
Gullies and drainage systems cleansed		
Erosion and scour check at surface water discharge point		
Final drainage CCTV survey by certified company		

<b>Areas for inspection</b>		
<b>Inspection</b>	<b>Summary Details</b>	<b>Date passed by LCC Authorised Representative</b>
Grassed and overrun areas prepared, mown and edged back		
Confirm correct tree planting details are fully established		
Service margins marked in accordance with specification – no encroachment into service margins		
Signs and road markings correctly in place, with no deterioration of markings		
Lighting columns and signs are within area to be adopted as highway		
Visibility splays established		
As built survey drawings required		
As built level surveys of drainage infrastructure and carriageways		
Ensure foul and surface water drainage systems are certified to enter their maintenance period by the relevant water authority		
Any easements are in the correct location, no other encroachments and no permanent structures positioned within the area		
Any obvious other defects		

In order for the development to be entered into the 12 months maintenance period, the Developer will also need to provide copies of satisfactory certificates for the completed construction stages and pay any sums specified to cover possible future risk to the Authority associated within the lack of inspection and/or testing at the correct stages.

**The alternative course of action to the above is for the Developer to remove all works and materials down to the lowest stage of construction which has an approval certificate to allow the specified inspections and testing to take place in accordance with the Section 38 Agreement.**

## CERTIFICATION OF DEVELOPMENT ROAD INSPECTION

### KEY STAGE T9 – PRE-MAINTENANCE PERIOD

This is to certify that the development has been inspected and that certificates for key construction stages have been satisfactorily notified and completed by:-

General Information	
<b>Development</b>	
<b>Developer</b>	

The development can now commence the 12 months maintenance period provided:-

- Any outstanding sums, to cover possible future risk to the Authority associated with the lack of inspection and/or testing at the correct stage, are paid and;
- The developer agrees to undertake any outstanding remedial works during the maintenance period.

#### Outstanding items to be rectified during the maintenance period

NB: The County Council's Street Lighting Engineer will also check the street lighting and any illuminated traffic signs during the maintenance period and he will contact you regarding any remedial works which may be required

Authorised representative of the County Council on behalf of the Executive Director for Place
Signed:
Date:
Lincolnshire County Council Technical Manager
Counter Signed:
Date:

## DEVELOPMENT ROAD INSPECTION CERTIFICATE

### KEY STAGE T10 – PRE-ADOPTION

In accordance with the Section 38 Agreement for the development known as:-

General Information	
<b>Development</b>	
<b>Developer</b>	

In order for this development to be entered into the 12 months maintenance period in accordance with the Section 38 Agreement, a Pre-Maintenance period inspection must be undertaken between the person named in the S38 Agreement as being responsible for managing construction and quality for this developer and the authorised representative of the County Council.

Areas for inspection	
Inspection	Date passed by LCC Authorised Representative
Any outstanding issue identified at Key Stage Pre Maintenance inspection	
Road and footways correctly swept & cleaned	
Overall condition of all surfaces, ensuring there are no outstanding defects, temporary reinstatements or excavations	
Any damage to kerbs, channel blocks or edgings are replaced	
Confirm no sediment build up in the pervious pavement, swales or filter strips	
Confirm pervious pavement is draining effectively, no settlement in levels has taken place & no block migration	
Any weed growth to be treated	
Gullies and drainage systems cleansed	
Final drainage CCTV survey by certified company	
Grassed and overrun areas prepared, mown and edged back	
Confirm tree planted areas are established	
Service margins marked in accordance with specification – no encroachment into service margins	
Any easements are in the correct location, no other encroachments and no permanent structures positioned within the area	
Signs and road markings are correctly in place, with no deterioration of markings	
Street Lighting approved for adoption by LCC Street Lighting	
Visibility splays established	
CDM information to include: <ul style="list-style-type: none"> <li>• Health and Safety File</li> <li>• As-built drawings</li> <li>• SuDS Management Plan</li> <li>• Private management company details</li> </ul>	



<b>Areas for inspection</b>	
<b>Inspection</b>	<b>Date passed by LCC Authorised Representative</b>
Obtain copies of signed S104 agreement and plan or vesting certification	
All sales advertising signs are removed from site and existing highway street furniture	
Obtain a copy of the as-built drawings meeting requirements of the DRS	
Any obvious other defects	

## CERTIFICATION OF DEVELOPMENT ROAD INSPECTION

### KEY STAGE T10 – PRE-ADOPTION

This is to certify that the development has been inspected successfully and there are no outstanding issues. The Development can now be formally adopted by the County Council as highway maintainable at the public expense.

General Information	
Development	
Developer	

Authorised representative of the County Council on behalf of the Executive Director for Place
Signed:
Date:
Lincolnshire County Council Technical Manager
Counter Signed:
Date:

**NB: You will be sent a separate letter detailing the formal date of adoption, the areas to be adopted and when the bond can be cancelled.**

## DEVELOPMENT ROAD CONSTRUCTION CERTIFICATE

### KEY STAGE X1 – STRUCTURES

In accordance with the Section 38 Agreement for the development known as:-

General Information	
Development	
Developer	

The developer is required to obtain from the County Council, as Highway Authority, certification that the STRUCTURES works on this development have been carried out in accordance with the specification and agreed drawings and inspected and tested by an authorised representative of the County Council at the correct time.

The requirements for inspection, notice, testing, approval and certification for different types of Highway Structure are defined on the "*INSPECTION REQUIREMENTS FOR STRUCTURAL WORKS*" sheet. For all other structures, the requirements must be agreed with LCC representatives in advance of commencement of the works.

In order to meet the above requirements, the nominated person named in accordance with the Section 38 Agreement as being responsible for managing construction and quality for the developer, in addition to ensuring compliance with this specification, shall notify in good time (**a minimum of two clear working days' notice**) and provide facility for the authorised representative of the County Council to carry out the required inspections, tests and the like detailed below:-

#### Key to requirements

'M' - Mandatory testing to be undertaken by contractor, with the results passed to LCC for approval. Some testing may be required to be witnessed by LCC representatives on site, as noted below.

'A' – Prior approval of process/material sourced by LCC before commencement of associated operation.

'N' - Notice to LCC of activity commencement is required, to allow LCC representatives the opportunity to be present on site during these operations to witness, inspect and test during the execution of the specified operations.

'I' - Inspection of works on activity completion. Several items shall be expected to be inspected during a site visit. For concrete pours, this will be in the form of a pre-pour inspection by LCC representatives.

**Sufficient time must be allowed for the rectification of any defects discovered during inspection before the commencement of subsequent operations, notably the delivery of fresh concrete.**

'C' - Certification on successful completion of all required structural works.

\* Note LCC requirements for 6N grading

Inspection, Test, Notification, Approval and Certification Stages					
Item		Key	Frequency / Inspection Timing	Completed <sup>3</sup>	
				By	Date
Earthworks & Backfill	Formation	I	All areas <sup>*1</sup>		
	Lower Bedding to CSS	A	All sources		
	Lower & pipe bedding	A	All sources		
	Upper bedding	I	All areas		
	Excavation prior to backfill	I	All areas		
	Surround material to CSS	A	All sources		
	Structural backfill material	A	All sources		
	Geotextiles	I,N	All areas		
	Sub-base	N	All areas – as Key Stage T3		
Drainage	Drains < 600mm dia - prior to backfill	I	All areas – as Key Stage T1		
	Drains < 600mm dia - following backfill	I	All areas – as Key Stage T1		
	Weep Holes	I	All, prior to any backfilling		
	Pore water relief drains	I	All, prior to any backfilling		
	Pipes >= 600mm diameter	N	All lengths		
	Pitching / Facings / Revetments	I	All		
	Service ducts & diversions	A	Before commencement		
Surfacing		I,N	All areas – as Key Stage T8		
Structural Concrete	Blinding	I	All areas		
	Shuttering	I	All, as pre-pour inspection		
	Reinforcement	I	All, as pre-pour inspection		
	Dowel bars & sleeves	I	All, as pre-pour inspection		
	Construction joints	I	All, as pre-pour inspection		
	Concrete Pours	N	All, to be witnessed by LCC		
	Compressive Strengths (Cube tests)	M	3x28 day cubes, each pour/15t		
	Water stop / water bar	I	All, as pre-pour inspection		
Pre-cast	Installation of pre-cast box, beam, units	N	All, to be witnessed by LCC		
	Installation of pipes > 600mm dia	N	All lengths, before backfill		
	Manhole / catch-pit chambers	I	All		
	Filling of clutches / lifting eyes	I	All		
	Jointing material	I	All		
Brickwork	Fixings, channels etc.	I	All		
	Brickwork / Blockwork	I	All		
	Stone copings	I	All		
Water-proofing	Spray applied waterproofing	N	To be witnessed by LCC Rep.		
	Pin hole 'Holiday' testing	M	To be witnessed by LCC Rep.		

Inspection, Test, Notification, Approval and Certification Stages					
Item		Key	Frequency / Inspection Timing	Completed <sup>*3</sup>	
				By	Date
	Sheet applied waterproofing	I	All		
	Expansion joints	A,N	All		
	Movement joints	I	All		
	Other Below ground waterproofing	I	All		
RRS	Steel Parapets (Veh/Ped)	I	All		
	Brick Parapets	I	All		
	Safety barriers	I	All		
	Timber Fences	I	All		
Steel work	Trial Erection	M	All		
	Final Erection	I,N	To be witnessed by LCC Rep.		
	Preparation for protective systems	A,I	All, req. to be confirmed		
	Completion of protective systems	I	All, req. to be confirmed		
Completion		C	All structures		
As-built drgs, inv. sheet & maint. manual		I	Info to be supplied for review		
Pre-Adoption		C	All structures		

Mandatory testing to be undertaken by the Contractor		
Item	Frequency	Results passed by LCC Authorised Representative
Compaction of 6N material in backfill to structures	All areas, minimum daily or 1 test every 100t of material	
Fresh concrete - workability	Every delivery – All loads outside of specification tolerances shall be rejected. No additional water shall be added to concrete on site	
Fresh concrete - strength	3 test cubes to be taken every 15t (each delivery) or part thereof. To be tested at age 28 days only*2. Care to be taken in correctly curing the test cubes.	
Concrete (in-situ only) – cover to reinforcement	Cover measurement survey of all reinforced concrete surfaces, on a 500 mm grid over the whole structure.	
Spray applied waterproofing material - bond	2 tests minimum daily, per 100m2 of waterproofing area.	
Spray applied waterproofing material – pinhole tests	Entire waterproofing membrane, and all defects after repair	
Trial erection of steelwork	For all structures	

\*1 – In-situ ground testing may be required to corroborate design values with the exposed

formation material.

\*<sup>2</sup> – Additional cubes tests at earlier age may be required to demonstrate sufficient early structural strength for subsequent operations or use by traffic.

\*<sup>3</sup> – To be endorsed by LCC Authorised Representative once all operations are satisfactorily completed.

Should the named representative of the developer fail to notify, inform or allow facility for the authorised representative of the County Council to carry out the above Inspections, Tests and the like at the correct time, the County Council may refuse to sanction adoption of the structure and any associated carriageway, footway etc. dependent on the structure for access.

**Generally, retrospective testing will not be sufficient to demonstrate the suitability of a structure for adoption.**

### **Payment by the Developer for Failure to Achieve Certification of the Key Stage of STRUCTURES**

In addition and irrespective of any retrospective testing or the outcome of such tests, should the Developer fail to obtain the relevant certificate for the key stage of STRUCTURES on this development or proceed without the consent of the Executive Director for Place (or persons authorised by him), then the Council will require the Developer to pay a sum to the Council to cover possible future risk to the Authority associated with the lack of inspection and/or testing at the correct stage.

**Any deficiency or failure potentially affecting public safety will require rectification prior to adoption.**

**Any deficiency or failure affecting the potential durability of the structure may be subject to an additional risk payment.**

This additional risk payment will generally be calculated as a substantial reduction in the "time to replacement" in, and/or additional maintenance operations added into the, commuted sum calculation as determined by LCC representatives.

**The alternative course of action to the above is for the Developer to remove all works and materials down to the lowest stage of construction which has an approval certificate to allow the specified inspections and testing to take place in accordance with the Section 38 Agreement.**

## CERTIFICATION OF DEVELOPMENT ROAD CONSTRUCTION

### KEY STAGE X1 - STRUCTURES

This is to certify that the key construction stage of STRUCTURES has been satisfactorily notified and completed by:-

General Information	
<b>Development</b>	
<b>Developer</b>	

Development and that the key inspections and the key tests, above, have been successfully completed.

#### Authorised representative of the County Council on behalf of the Executive Director for Environment and Economy

Signed:

Date:

#### Lincolnshire County Council Technical Manager

Counter Signed:

Date:

**Notwithstanding the above, the responsibility for all works and supervision on Development Roads lies with the developer. It is totally his responsibility to ensure and achieve compliance with the specification. Inspections and testing carried out by Lincolnshire County Council and this certification do not absolve the developer from this responsibility in any way.**

## APPENDIX 2

### Section 38 Highway and Drainage Drawing Package General Requirements to Commence Detailed Design Check

This form and checklist must be completed by the Engineering Consultant /Developer for all Section 38 submissions, and the following information is required before the Section 38 can be processed by the Highway and Flood Authority. Any information not provided will increase the time taken to gain technical approval and complete the agreement. **This checklist is not exhaustive and additional information may be required. Please also refer to the Highway and Flood Authority's detailed requirements for Major and Minor developments, provided in the [Appendices to the current Development Roads and Sustainable Development Design Approach](#), and can be accessed via the Lincolnshire County Council website.**

You are advised that your submission should have regard to the good practice contained within the [Lincolnshire Development Road and Sustainable Drainage Design Approach](#), and YOU MUST ensure that the proposed development layout, design and road construction details etc. comply with the [Lincolnshire Development Roads and Sustainable Drainage Specification and Construction](#).

General Information	
<b>Site Name:</b>	<b>Date of Drawing Package &amp; Ground Investigation Report Submission:</b>
<b>Site Location &amp; Address:</b>	<b>Planning Number &amp; Date Granted:</b>
<b>Name &amp; Registered Office Address of Developer:</b>	<b>Developer Lead Contact Details (include email &amp; telephone):</b>
<b>Name &amp; Registered Office Address of Engineering Consultant:</b>	<b>Engineering Consultant Lead Contact Details: (include email &amp; telephone)</b>
<b>Name &amp; Registered Office Address of Solicitor:</b>	<b>Solicitor Lead Contact Details: (include email &amp; telephone)</b>
<b>Name, Registered Office Address &amp; Lead Contact of Management Company: (if applicable - include email &amp; telephone)</b>	<b>Company Name, Registered Office Address &amp; Lead Contact of Bond Guarantor: (include email &amp; telephone)</b>



Type of Drainage Scheme (please tick):			
SuDS	<input type="checkbox"/>	Traditional	<input type="checkbox"/>
		Combination	<input type="checkbox"/>

**Check list showing information required to commence the detailed design check:**

- Please ensure all drawings have a separate drawing number to avoid confusion when issuing technical approval.
- Please provide one hard copy and one electronic copy sent to [developmentmanagement@lincolnshire.gov.uk](mailto:developmentmanagement@lincolnshire.gov.uk) complete copies of the drawings and details as follows: -

Required Documents Checklist		
Information	Tick	Drawing No./Ref./Notes/NA
<b>1. £2,150 up-front fee to carry out technical review. Please quote the site location, phase and FAO S38 officer name (if known). Include reference 'LP1015 RH103226'.</b>	<input type="checkbox"/>	
<b>2. Drawing issue sheet (to be provided with every set of revisions).</b>	<input type="checkbox"/>	
<b>3. Full Planning Permission Notice and approved layout drawing.</b>	<input type="checkbox"/>	
<b>4. Site Location Plan (1:2500)</b>	<input type="checkbox"/>	
<b>5. SuDS Construction Management &amp; Maintenance Plan Method Statement to include:</b>	<input type="checkbox"/>	
A SuDS construction method statement phasing plan and maintenance schedule (incorporating temporary site drainage arrangements during construction) is required for all SuDS related construction activities and post adoption maintenance.	<input type="checkbox"/>	
<b>6. General Section 38/Engineering Layout coloured drawing (1:500/1:1250) to include:</b>	<input type="checkbox"/>	
Areas of proposed highway offered for adoption – coloured green with solid red outline.	<input type="checkbox"/>	
Site Boundaries.	<input type="checkbox"/>	
Existing boundaries (on and around site).	<input type="checkbox"/>	
Positions of all carriageways, footways, footpaths, cycle ways, verges, service strips, visibility splays, traffic calming features.	<input type="checkbox"/>	
Existing and proposed Foul and Surface Water drainage including gully positions and gully laterals highway drainage needs to be identified in a different colour.	<input type="checkbox"/>	
Where applicable each dwelling; draining private surface water to the adoptable highway SUD should be clearly identified on the plan and coloured purple.	<input type="checkbox"/>	
Watercourses.	<input type="checkbox"/>	
Finished ground floor levels.	<input type="checkbox"/>	
Storage/attenuation systems.	<input type="checkbox"/>	
Outfalls/headwalls.	<input type="checkbox"/>	
Existing trees and proposed locations.	<input type="checkbox"/>	
Easements to be coloured blue.	<input type="checkbox"/>	

Required Documents Checklist		
Information	Tick	Drawing No./Ref./Notes/NA
Position of dwellings, garaging and/or parking spaces with vehicular crossings, traffic signs, road markings, structures.	<input type="checkbox"/>	
Chainage every ten metres.	<input type="checkbox"/>	
Falls and cross-falls of footways and carriageways.	<input type="checkbox"/>	
Carriageway gradients where applicable.	<input type="checkbox"/>	
Street Lighting locations.	<input type="checkbox"/>	
<b>7. Longitudinal Section Drawing (1:500 Horizontal/1:100 Vertical) to include:</b>	<input type="checkbox"/>	
Existing and proposed levels for the centre line, channels, gradients and vertical curves.	<input type="checkbox"/>	
Surface and Foul Water Drainage profiles, including positions of chambers, gradients, pipe diameters, cover and invert levels and protection.	<input type="checkbox"/>	
Highway drainage should be identified in a different colour.	<input type="checkbox"/>	
Pipe material.	<input type="checkbox"/>	
Pipe strength.	<input type="checkbox"/>	
Bedding classification and details.	<input type="checkbox"/>	
Ground water/watercourse levels.	<input type="checkbox"/>	
<b>8. Cross Section Drawing (1:100 Horizontal/1:50 Vertical) to include:</b>	<input type="checkbox"/>	
The road intervals of not greater than 30 metres where the adjoining site levels vary $\pm 0.5$ metres from finished footway levels.	<input type="checkbox"/>	
<b>9. Standard Detail Drawing (1:10/1:20) to include:</b>	<input type="checkbox"/>	
Typical Cross Sections of carriageway, footway, cycle ways surface details, kerb details vehicle accesses, pedestrian crossings with tactile paving, verge, service strips, tie-in, build-outs, shared surfaces, gullies, chambers, pipes and bedding suds features and, and any other highway features. <b>*Note:</b> The above details are for Minor and Major Access Roads, Shared Surface Roads and Local Distributor Roads.	<input type="checkbox"/>	
<b>10. Kerbing Arrangement Drawing (1:500) to include:</b>	<input type="checkbox"/>	
All types and positions of precast concrete kerbs, blocks and edgings across the site.	<input type="checkbox"/>	
<b>11. Drainage Catchment Drawing (1:500) to include:</b>	<input type="checkbox"/>	
Surface water catchment for gullies (maximum 180sqm permitted).	<input type="checkbox"/>	
Surface water catchment for SuDS features adjacent carriageway.	<input type="checkbox"/>	
<b>12. Signs and Lines Drawing (1:500) to include:</b>	<input type="checkbox"/>	
Site layout plan showing signs and lines in accordance with – The Traffic Signs Regulations and General Directions; and Traffic Signs Manual Chapters 3 & 5; and cross sections of bollard and pole foundations.	<input type="checkbox"/>	
<b>13. Street lighting Drawing (1:500) to include:</b>	<input type="checkbox"/>	
Street lighting layout plan and specification in accordance with BS5489.	<input type="checkbox"/>	
<b>14. Landscaping Layout Drawing (1:500) to include:</b>	<input type="checkbox"/>	

Required Documents Checklist		
Information	Tick	Drawing No./Ref./Notes/NA
Details of planting, trees species /size/positions any existing trees to be retained tree pit details, grassed areas, play grounds and equipment, fencing, walls and confirmation of land dedicated/ownership.	<input type="checkbox"/>	
<b>15. Specialist Drawings (1:1250) to include:</b>	<input type="checkbox"/>	
Bridges, Culvert, any pipework over 600mm diameter, headwalls, retaining walls and any other non-standard features.	<input type="checkbox"/>	
Existing Statutory Services and utility plans showing surrounding location of proposed development.	<input type="checkbox"/>	
<b>16. Statutory Consents and other Permissions to include:</b>	<input type="checkbox"/>	
Discharge consents/licences to watercourses by IDB or others.	<input type="checkbox"/>	
Rights to lay pipes on third party land/easements.	<input type="checkbox"/>	
Easement details to be shown coloured blue.	<input type="checkbox"/>	
Permission of riparian owner for discharge.	<input type="checkbox"/>	
S104 Foul and Surface Water Agreements.	<input type="checkbox"/>	
Land drainage consent management company drainage agreements.	<input type="checkbox"/>	
<b>17. Drainage Strategy, Layout and Construction Details to include:</b>	<input type="checkbox"/>	
Drainage Strategy	<input type="checkbox"/>	
Drainage Master plan showing multiple phases of construction.	<input type="checkbox"/>	
Approved Flood Risk Assessment or Flood Risk Statement.	<input type="checkbox"/>	
Contoured flood routing plan to include site contours.	<input type="checkbox"/>	
Groundwater levels and location of, and impacts on, any Surface Water Safeguard Zones, Groundwater Safeguard Zones and/or Groundwater Nitrate Vulnerable Zones.	<input type="checkbox"/>	
Manholes	<input type="checkbox"/>	
SuDS Scheme Maintenance Plan.	<input type="checkbox"/>	
SuDS Method Statement relating to all phases. (See page 10 in Development Road and Sustainable Drainage Specification and Construction.)	<input type="checkbox"/>	
Attenuation device chambers.	<input type="checkbox"/>	
Storage chambers.	<input type="checkbox"/>	
Headwalls	<input type="checkbox"/>	
Other ancillary structures.	<input type="checkbox"/>	
<b>18. CDM Requirements</b>	<input type="checkbox"/>	
CDM file containing risk assessments for the design, construction, operation and maintenance of the highway and drainage system.	<input type="checkbox"/>	
<b>19. Copies of Hydraulic Design Calculations to include:</b>	<input type="checkbox"/>	
Catchment and sub-catchment plan.	<input type="checkbox"/>	
Network details.	<input type="checkbox"/>	
Simulation results for design storm RP, 1:1 RP, 1:2 RP, 1:30 RP, and 1:100 RP plus 40% for climate change.	<input type="checkbox"/>	
Storage and attenuation devices.	<input type="checkbox"/>	
Soakaway infiltration designs.	<input type="checkbox"/>	
Soaked CBRs at formation level.	<input type="checkbox"/>	

Required Documents Checklist		
Information	Tick	Drawing No./Ref./Notes/NA
Subgrade particle size distribution.	<input type="checkbox"/>	
Typical groundwater table level.	<input type="checkbox"/>	
Other data as required for design.	<input type="checkbox"/>	
<b>20. Structures affecting the highway</b>	<input type="checkbox"/>	
Any non-adoptable structure that is within 3.66m of the highway boundary and/or 1.37m or higher, as measured from the finished level of the highway will require submission of structural calculations to demonstrate its suitability.	<input type="checkbox"/>	
Appendix 3 must be completed and submitted where: <ul style="list-style-type: none"> <li>any bridge, box culvert, pipe (regardless of shape), arch, span, deck, cantilever, foot bridge or similar of width 600mm or higher.</li> <li>any retaining wall, headwall, wing-wall, gabion wall, training wall, reinforced embankment, piled wall, or similar with a retained fill height of 600mm or higher.</li> </ul>	<input type="checkbox"/>	
<b>21. Ground Investigation Report to include:</b>	<input type="checkbox"/>	
Site description, site history and site work.	<input type="checkbox"/>	
Significant constraints (incl. soluble rocks, landslides, shallow mining, shallow groundwater, made ground).	<input type="checkbox"/>	
Drainage potential (incl. depth to water table, permeability of superficial deposits, thickness of superficial deposits, permeability of bedrock, presence of floodplains). Critical to consider infiltration, groundwater table, greenfield run-off & surface water storage.	<input type="checkbox"/>	
Ground stability.	<input type="checkbox"/>	
Areas of contaminated land.	<input type="checkbox"/>	
Laboratory work.	<input type="checkbox"/>	
Geology and geological maps.	<input type="checkbox"/>	
Bore hole/trial pit locations and other information.	<input type="checkbox"/>	
Detailed infiltration assessment.	<input type="checkbox"/>	
Where possible, detailed evidence of groundwater table levels over recent 12 month period or validated evidence.	<input type="checkbox"/>	
Soaked CBR's where SuDS features are proposed and un-soaked CBR's where traditional drainage is proposed and particle size distribution if required.	<input type="checkbox"/>	
Proposed Design CBR values and road construction thickness by a UKAS Accredited Laboratory.	<input type="checkbox"/>	
<b>22. Contaminated Land Reports Drawings to include:</b>	<input type="checkbox"/>	
Areas of contaminated land	<input type="checkbox"/>	
Borehole and trial pit logs	<input type="checkbox"/>	
<b>23. Title Documents</b>	<input type="checkbox"/>	
Up-to-date coloured Copy Entries of Title or Epitome of Title to the land in question.	<input type="checkbox"/>	

The following notes 1 to 6 shall be incorporated on all drawings submitted:

- 1) *"The specification in all respects shall be in accordance with the Lincolnshire County Council Development Road and Sustainable Drainage Specification and Construction."*

- 2) *“Within the catchment of traditional drainage design, the minimum longitudinal fall for highways, without channel blocks shall be 1 in 150, and with channel blocks 1 in 250.”*

See Clause 10.1 of the Development Road and Sustainable Drainage Specification and Construction. In addition, ensure that the first section of any side road falls away from the road from the road to which it is connecting. If general topography requires it to rise, this change of direction should take place after the first set of gullies. This is to ensure a ‘false channel’ with associated drainage problems is not created in the bellmouth of junctions.

- 3) *“General deterioration of the existing highway/footway/verges created through construction of the new Section 38 Development will be reinstated to the Development Road and Sustainable Drainage Specification and Construction at the developers’ own cost at the agreement of the inspecting Development Management Officer.”*

- 4) *“No Private surface water shall discharge onto the adoptable highway.”*

- 5) *“No private structural features shall overhang the adoptable highway.”*

- 6) *“No private retaining walls exceeding 1.37 metres shall be within 3.66 metres of the highway boundary.”*

**It should be noted that:**

Where the system has been designed on Microdrainage, the developer may wish to submit electronic files from Microdrainage for checking. This will assist in accelerating the check as the design can be analyzed by Microdrainage CasDef/APT.

Should the developer wish to submit AutoCAD files, he should attach the relevant pen setting files (ctb). Plans should be folded to A4 size.

### APPENDIX 3

EXTERNALLY PROMOTED HIGHWAY STRUCTURES			
Development			
Developer			
Structures Design Submission Requirements			
Item	Item Description (see associated guidance notes)	Included	Not required
1	General arrangement drawing	<input type="checkbox"/>	
2	Location plan	<input type="checkbox"/>	
3	Detailed construction drawings	<input type="checkbox"/>	<input type="checkbox"/>
4	Reinforcement drawings	<input type="checkbox"/>	<input type="checkbox"/>
	Reinforcement schedules	<input type="checkbox"/>	<input type="checkbox"/>
5	Land plans	<input type="checkbox"/>	
6	Design certificate	<input type="checkbox"/>	<input type="checkbox"/>
	Check certificate	<input type="checkbox"/>	<input type="checkbox"/>
	<i>Approval in Principle</i> document, including TAS	<input type="checkbox"/>	<input type="checkbox"/>
7	Specification requirements	<input type="checkbox"/>	<input type="checkbox"/>
8	Designed concrete mix	<input type="checkbox"/>	<input type="checkbox"/>
9	Detailed design calculations	<input type="checkbox"/>	<input type="checkbox"/>
	Design calculations indicated as checked	<input type="checkbox"/>	<input type="checkbox"/>
10	Assessment of need to provide a vehicle restraint system	<input type="checkbox"/>	<input type="checkbox"/>
11	Departure from standards submission	<input type="checkbox"/>	<input type="checkbox"/>
12	Proof of Flood Defence Consent (EA/IDB)	<input type="checkbox"/>	<input type="checkbox"/>
	Proof of approvals from others	<input type="checkbox"/>	<input type="checkbox"/>
13	Ground investigation report	<input type="checkbox"/>	<input type="checkbox"/>
14	Details of provision for buried services	<input type="checkbox"/>	
15	Temporary works proposals	<input type="checkbox"/>	<input type="checkbox"/>
Is structure to be offered for adoption?		Yes	<input type="checkbox"/> No <input type="checkbox"/>
Checked by:		Date:	
Externally Promoted Highway Structures - Document Guidance notes:			
1	General arrangement drawing (a separate drawing is required for each structure), including plan, cross section, long section and elevations.		
2	Location plan, showing detailed method of maintaining access to properties for the future replacement of structure.		
3	Detailed construction drawings, showing detailed dimensions and levels of all structural elements (sufficient for our inspector to adequately check the construction on site), and include – earthworks details, bed and backfill, formwork finishes, waterproofing (incl. protective layer), concrete specifications, brickwork and copings, movement joints and sealants, surfacing, impermeable verges, parapet details (including protective paint system), drainage. Final earthworks proposals around headwalls should be shown to demonstrate the bank slopes do not exceed 1:1.5.		
4	Reinforcement drawings and schedules (must be checked), cover must be specified on the drawings (minimum 50mm). The minimum expected reinforcement will be 16mm Ø bars at 150mm ctrs.		
5	Land plans; showing structure to be wholly located within the adopted highway, and 3m minimum maintenance easement provided from all extents of the structure.		
6	Design and check certificates, and where appropriate an Approval in Principle document (for CAT1, 2, 3 structures) including TAS – in accordance with BD2.		
7	Specification requirements and any amendments to the specification. The drawings should		

	<p>note: -</p> <ul style="list-style-type: none"> <li>• LCC minimum structural concrete mix for durability: Strength C32/40, min. cement content 325kg/m<sup>3</sup>, max. W/C ratio 0.45, maximum aggregate size 20mm.</li> <li>• All buried structural concrete must be protected with 2 coats of a suitable below ground waterproofing material.</li> <li>• 6N material to be graded as type 1 sub-base (all other characteristics remain, including the requirement to demonstrate compaction to 95% density at OMC).</li> <li>• Bricks must have a strength of greater than 75 N/mm<sup>2</sup> and water absorption of less than 7% (equivalent to class B engineering), laid in class 3 mortar.</li> </ul>
8	Designed concrete mix minimum constituents for structural concrete in accordance with BS8500, and demonstrating a durability of 100 years for the appropriate exposure classification (RC40 is not acceptable).
9	<p>Detailed design calculations (strictly, and only, in accordance with relevant D.M.R.B. standards or UK Bridges parts of Euro codes) for all structural elements, including box culverts, headwalls, buried pipes, distribution slabs, retaining walls etc.</p> <ul style="list-style-type: none"> <li>• The calculations must be sufficiently annotated and must be checked (note an independent check may be necessary if required by BD2).</li> <li>• Characteristic values of ground strength parameters determined by the Ground Investigation must be used for the geotechnical design, and in the absence of a GI only very conservative values will be accepted.</li> <li>• To include calculations demonstrating the design stability, adequacy of sections and reinforcement (in bending and shear), durability (crack widths) and early thermal cracking.</li> <li>• All areas and elements of the structure must be shown to be adversely affected by the action of vehicle loading ("Pedestrian loading" is only for footbridges).</li> <li>• The calculations must result in unambiguous conclusions and the design shown on the detailed construction and reinforcement drawings must equal or exceed these conclusions.</li> </ul>
10	Assessment of need to provide a vehicle restraint system in accordance with TD19 or LCC standard (" <b>PVRSAS</b> ") as appropriate. See HAT 51
11	Departure from standards submission for endorsement (required for the omission of safety barriers from ends of vehicle parapets).
12	Proof of approvals necessary from others (notably <b>Flood Defence Consent</b> from the appropriate drainage authorities, indicating agreement to proposed waterway areas and invert levels).
13	Ground investigation report, including confirmation of values used for allowable bearing pressures for foundations in any structural analysis.
14	Details of provision for both current and future buried services to pass over the structure without undue disturbance (many spare ducts).
15	Any temporary works proposals, working methods or restrictions and an assessment of their effects this or any other affected structure.
For further details see <b>Small Highway Structures Design Guide</b> document	